

TT481W

smar
First in Fieldbus

FEB / 2020
TT481W
VERSION 1

Wireless**HART**

OPERATION & MAINTENANCE,
INSTRUCTIONS MANUAL

WirelessHART™ PRESSURE TRANSMITTER WITH 4 OR 8 CHANNELS



smar
NOVA SMAR S/A
www.smar.com.br

Specifications and information are subject to change without notice.
Up-to-date address information is available on our website.

[web: www.smar.com/contactus.asp](http://www.smar.com/contactus.asp)

NOTE

This manual is compatible with version 1.XX, where 1 denote software version and XX software release. The indication 1.XX means that this manual is compatible with any release of software version 1.

Waiver of responsibility

The contents of this manual abides by the hardware and software used on the current equipment version. Eventually there may occur divergencies between this manual and the equipment. The information from this document are periodically reviewed and the necessary or identified corrections will be included in the following editions. Suggestions for their improvement are welcome.

Warning

For more objectivity and clarity, this manual does not contain all the detailed information on the product and, in addition, it does not cover every possible mounting, operation or maintenance cases.

Before installing and utilizing the equipment, check if the model of the acquired equipment complies with the technical requirements for the application. This checking is the user's responsibility.

If the user needs more information, or on the event of specific problems not specified or treated in this manual, the information should be sought from Smar. Furthermore, the user recognizes that the contents of this manual by no means modify past or present agreements, confirmation or judicial relationship, in whole or in part.

All of Smar's obligation result from the purchasing agreement signed between the parties, which includes the complete and sole valid warranty term. Contractual clauses related to the warranty are not limited nor extended by virtue of the technical information contained in this manual.

Only qualified personnel are allowed to participate in the activities of mounting, electrical connection, startup and maintenance of the equipment. Qualified personnel are understood to be the persons familiar with the mounting, electrical connection, startup and operation of the equipment or other similar apparatus that are technically fit for their work. Smar provides specific training to instruct and qualify such professionals. However, each country must comply with the local safety procedures, legal provisions and regulations for the mounting and operation of electrical installations, as well as with the laws and regulations on classified areas, such as intrinsic safety, explosion proof, increased safety and instrumented safety systems, among others.

The user is responsible for the incorrect or inadequate handling of equipments run with pneumatic or hydraulic pressure or, still, subject to corrosive, aggressive or combustible products, since their utilization may cause severe bodily harm and/or material damages.

The field equipment referred to in this manual, when acquired for classified or hazardous areas, has its certification void when having its parts replaced or interchanged without functional and approval tests by Smar or any of Smar authorized dealers, which are the competent companies for certifying that the equipment in its entirety meets the applicable standards and regulations. The same is true when converting the equipment of a communication protocol to another. In this case, it is necessary sending the equipment to Smar or any of its authorized dealer. Moreover, the certificates are different and the user is responsible for their correct use.

Always respect the instructions provided in the Manual. Smar is not responsible for any losses and/or damages resulting from the inadequate use of its equipments. It is the user's responsibility to know and apply the safety practices in his country.

TABLE OF CONTENTS

INTRODUCTION VII

INSTALLATION FLOWCHART XIII

SECTION 1 - INSTALLATION 1.1

- GENERAL..... 1.1
- MOUNTING 1.1
- BATTERY MODULE WIRING 1.4
- INSTALLATION IN HAZARDOUS LOCATIONS 1.6
- INTRINSICALLY SAFE..... 1.6

SECTION 2 - OPERATION 2.1

- FUNCTIONAL DESCRIPTION-HARDWARE..... 2.1
- TEMPERATURE SENSOR 2.2
 - THERMOCOUPLES 2.2
 - THERMORESISTANCES (RTDS) 2.3
 - CURRENTS (4 TO 20MA) 2.4
- THE DISPLAY 2.4
- WRITTING PROTECTION 2.5

SECTION 3 - MAINTENANCE 3.1

- GENERAL..... 3.1
- DIAGNOSTICS WITH THE DISPLAY 3.1
- PROBLEMAS E SOLUÇÕES 3.1
- DISASSEMBLY PROCEDURE 3.1
- REASSEMBLY PROCEDURE 3.3
- RETURNING MATERIALS..... 3.4

SECTION 4 - TECHNICAL CHARACTERISTICS 4.1

- ORDERING CODE 4.4

APPENDIX A - SRF – SERVICE REQUEST FORM FOR TEMPERATURE TRANSMITTER..... A.1

APPENDIX B – BATTERY SAFETY DATASHEET B.1

INTRODUCTION

WirelessHART technology overview

The *WirelessHART* technology is based on a wireless mesh network communication protocol used in process automation applications. It adds wireless capabilities to the HART protocol, while maintaining compatibility with existing HART devices, commands and already known and used tools.

WirelessHART network

Basically, a *WirelessHART* network, defined in the HART specifications, consists of a host, a *WirelessHART* Gateway and one or more field devices and/or *WirelessHART* adapters. Together they compose a mesh network where the host and devices can communicate.

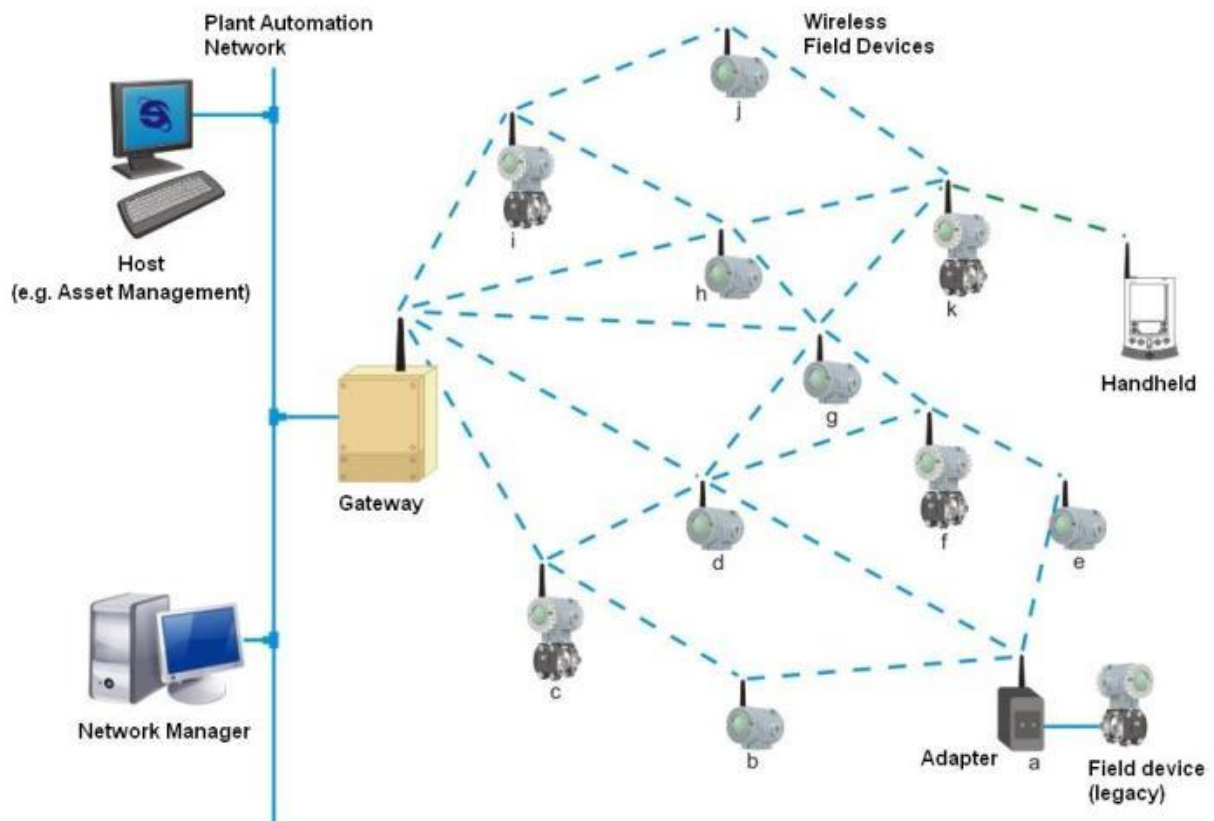

Host

The host, usually connected to the control network, is a workstation in which, e.g., can be installed an Human Machine Interface application, which allows an operator to interact with the process. Through the *WirelessHART* Gateway, the host can gather data from devices connected to the *WirelessHART* network. The host communicates with the *WirelessHART* Gateway using a communication protocol, for example, HSE, H1, Profibus or Modbus.

WirelessHART Gateway

It is a "translator" equipment. Thus it converts data from the host to the *WirelessHART* protocol, used by the devices connected to the *WirelessHART* network, and converts data from the devices to the host. In general, the *WirelessHART* Gateway incorporates the features of Network Manager and Access Point. Roughly, the access point can be understood as the *WirelessHART* radio installed at the gateway to communicate with devices connected to the wireless network.

Network Manager

The Network Manager is an application that can be embedded in the *WirelessHART* Gateway. On a *WirelessHART* network is only allowed to have one Network Manager. Among its responsibilities, the Network Manager distributes network identity (advertisement) publishing its existence, manages and authenticates the addition (joining) of devices to the network. It also distributes individual security keys (static or rotating) to the devices to ensure secure communication between it and the devices. The Network Manager assigns communication band to the devices already connected to the network that requested services to it, as well as manages the routes between the devices on the mesh network.

Specifically about the joining process of a *WirelessHART* device to the network, the Network Manager validates the Network ID and the Join Key attributes which are configured in the *WirelessHART* Gateway and *WirelessHART* devices.

The Network ID identifies a *WirelessHART* network in unique way. It is an unsigned integer attribute and must be configured on the *WirelessHART* Gateway and all *WirelessHART* devices. Considering a *WirelessHART* network installed in a plant, the permitted values for the Network ID ranges from 0 (hex 0x0000) to 32767 (0x7FFF hexadecimal).

The Join Key is a security key used to encrypt joining requests from *WirelessHART* devices that receive the advertisement with the Network Id identical to theirs. It may be single or each *WirelessHART* device may be configured with an individual Join Key. In the first case, the *WirelessHART* Gateway and all *WirelessHART* devices must be configured with the same Join Key. In the second case, which provides higher communication security level, (a) must be configured in the *WirelessHART* Gateway a list with individual Join Keys, i.e., a key for each *WirelessHART* device, and (b) you must configure each *WirelessHART* device with its individual Join Key. The Join Key is a hexadecimal string of 16 bytes. There is no restriction to the hexadecimal value of each byte. The table below shows examples of some join keys.

JOIN KEYS	16-BYTES HEXADECIMAL STRING
00000000000000000000000000000000	0x00, 0x00, 0x00, 0x00, 0x00, 0x00, 0x00, 0x00, 0x00, 0x00, 0x00, 0x00, 0x00, 0x00, 0x00, 0x00
000000000000000000000000000000302	0x00, 0x00, 0x00, 0x00, 0x00, 0x00, 0x00, 0x00, 0x00, 0x00, 0x00, 0x00, 0x03, 0x02, 0x00, 0x00
00000000FFFFFFFF0000000000000000	0x00, 0x00, 0x00, 0x00, 0x00, 0xFF, 0xFF, 0xFF, 0xFF, 0x00, 0x00, 0x00, 0x00, 0x00, 0x00, 0x00
550000000000000000000000000000AA	0x55, 0x00, 0x00, 0x00, 0x00, 0x00, 0x00, 0x00, 0x00, 0x00, 0x00, 0x00, 0x00, 0x00, 0x00, 0xAA

WirelessHART device

The *WirelessHART* field device is the device that connects to the process, being able to receive and/or transmit data on the *WirelessHART* network. It is a *WirelessHART* router (repeater) by nature, i.e., it is able to retransmit messages to/from other devices on the *WirelessHART* network.

WirelessHART Adapter

It is a bridge-type device, because it is able to provide data of HART + 4 to 20mA field device, legacy, to the host via *WirelessHART*. The adapter uses HART FSK standard communication, wired, to access data from HART field devices. And the adapter also uses the *WirelessHART* communication to provide data of the field device to the host. The adapter thus enables a HART field device to work on *WirelessHART* network.

We recommend a visit to the HART Communication Foundation website for additional information about the *WirelessHART* protocol such as *WirelessHART* project planning, positioning of devices, commissioning and verification tools, and practices.

Planning an *WirelessHART* network

The planning of a *WirelessHART* network is a task that is very similar to the activities that currently we perform with conventional wired devices. Furthermore, due to the simplicity of a mesh *WirelessHART* network, is exempt, in general, detailed field surveys, which are usually needed when we plan networks based on other wireless technologies.

Basically, a *WirelessHART* network involves planning, design, installation and commissioning phases.

Planning

This phase requires the execution of the steps below:

Scope definition

Clearly define the scope of the network. Answer the question: why do we need the wireless network? To monitor process variables or to implement a non-critical control? The answer to this question will facilitate the understanding between the team members responsible for the network and determine one or more process units in the plant. For each process unit, allocate a gateway with unique and specific Network ID. Outline the main field devices.

Identify potential sources of interference

Are there radio communications or other wireless networks in the plant? What protocols and frequencies do they use? Use high power? Although unlikely, given the robustness of the radios used by the *WirelessHART* technology, prior knowledge of the answers to these questions may identify potential sources of interference and to indicate the taking of preventive and/or limiting actions even before installation. For example, you can select a frequency channel as unavailable, adding it to the black list of frequencies that is under the *WirelessHART* Network Manager control.

Integration with the host

The gateway connects the *WirelessHART* field devices to the host system. Plan what devices and what data are needed. Also, the stations or applications which will process the data have to be clearly defined. From this set, among the protocols in the system, define which one will be used for integration with the host and with the existing tools for configuring the devices. After defining the protocol for integration, the user has to choose the gateway on the market that best meets your requirements.

Project

In the project phase, it is recommended the adoption of the practices below. Although conservative, these practices ensure robustness and scalability to the network.

- Define the Network ID that will be used for all devices in the process unit;
- Define if the Join Key will be common to all devices or individual and dedicated ;
- Define the policy to be used for the definition of devices (Long) Tags;
- Use a scale drawing of the process unit;
- Place the gateway in a strategic position in the process unit ;
- Plan networks with at least five devices;
- Install at least five devices within the gateway coverage area;
- Ensure that 25 % of the devices are within the gateway coverage area;

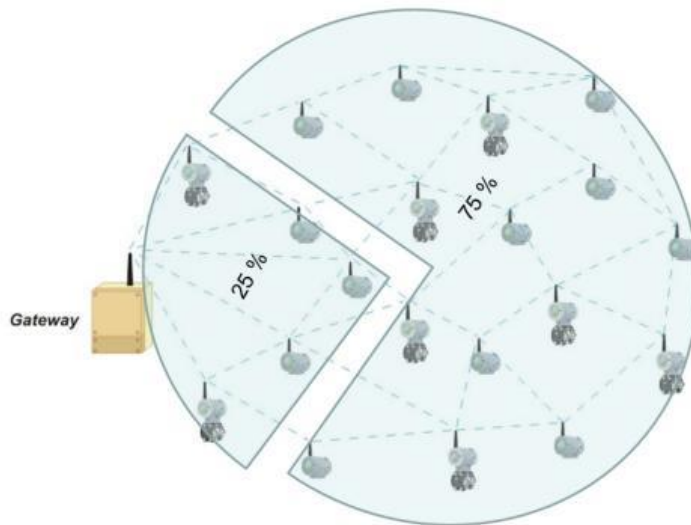

- Reposition the gateway as needed ;
- Check the coverage area of each device;
- Ensure that each device has three neighbors within its coverage area;

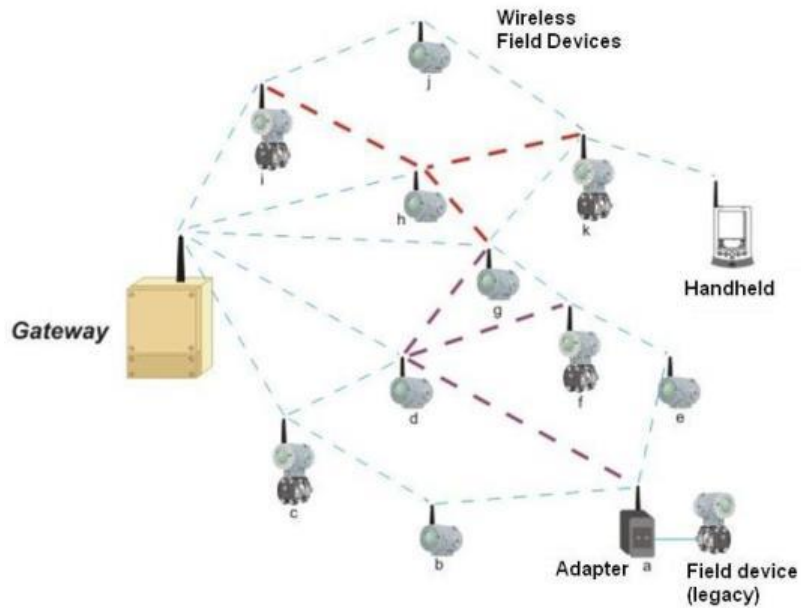

- Place the repeaters as needed.

Installation

As mentioned before, *WirelessHART* devices should be connected to the process and configured the same way as conventional wired HART devices.

Handheld terminals can be used normally. Just be sure of having it properly uploaded with the latest DD files of the devices. However, it is known that the *WirelessHART* devices have characteristics inherent to the technology. Because of this, it is recommended the adoption of practices mentioned below for positioning the gateway and devices.

- Install the gateway and the devices so that their antennas are vertical;
- Ensure that the antennas are at 0.5 m minimum distance of large obstacles or surfaces ;
- Ensure that the antennas of gateway and repeaters are 2 m above most obstacles within their coverage areas;

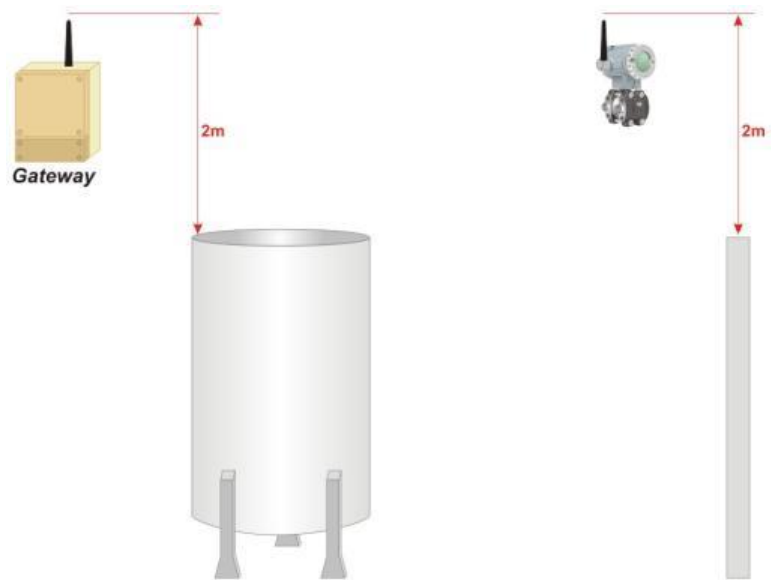

- If there are high devices, does not exceed 45 ° viewing angles between them;

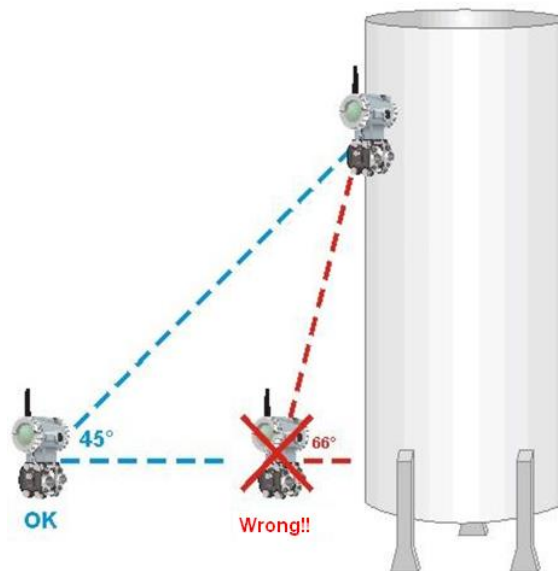

- Make sure that the gateway is integrated to the host system as planned.

Commissioning

Commissioning consists of testing the device and verifying its configuration data. The TT481 WirelessHART™ can be commissioned both before and after installation. The device commission can be performed through some configurator that interprets DD, for example, the DEVCOMDROID software (Android DDL interpreter), which can be used in conjunction with the HI331 (Bluetooth interface) to configure the Hart equipment.

To turn the transmitter on / off, use the SW1 (ON / OFF) terminal, as shown in Figure 1.4.

To connect the handheld configurator to the equipment, use the communication terminals "CN1 and CN2" on the terminal block. See Figure 1.4.

WirelessHART devices commissioning

a. Install and power on the gateway.

B. If not specified by the customer at the time of ordering, the Network ID and Join Key values for the gateway and devices should be according the factory default value. Note: It is strongly recommended that both be changed! To change these parameters install the gateway and all the devices on the network following the steps below. Once the network is fully functional it will be more practical to change them.

c. The device configuration must be carried out individually, starting with those closest to the gateway and moving away to the most distant so that the communication is being established correctly.

d. Always install the equipment with the antenna in the vertical direction. If the device is installed horizontally, consult Smar to purchase the antenna for horizontal assemblies, in order to be 90 ° with the equipment. No WirelessHART device should be located at the highest point of the plant, preventing it from lightning;

e. Turn on the device using the key on the left of the display and wait until it connects to the network (this time can vary from 2 minutes to up to 20 minutes, depending on the size of the network). The status of the device on the network can be checked via the display (section - Status indication on the display), maintenance port or gateway.

ATTENTION

If the device was not purchased together with the gateway, that is, if the gateway already has Network ID and Join Key values different from the factory values, it is necessary to configure these parameters on the device so that it connects correctly to the network : first configure Network ID and then Join Key, resetting the device after the settings.

f. As soon as these steps are performed for all devices in the network and they are connected correctly, it is time to change the values of Network ID and Join Key following the instructions according previous (e) step (if they have not already been changed). Network ID is any number between 0 and 32767 and identifies the network among others. Join Key is a key of 32 hexadecimal characters (0-9 or A-F) and enable the device to the configured network.

g. Configure the LongTAG parameter that identifies the equipment on the network.

H. Check that the engineering units of the equipment are in accordance with those required by the process.

i. Configure Burst mode parameters to publish desired measurements and status:

- Burst message: up to 3 messages can be configured with different commands and times;
- Minimum Time: is the time for publication of the variables;
- Maximum Time: must be longer than the minimum time and is only used in trigger mode (check the operation of the trigger mode in the device manual);
- Command: HART command which sends the variables desired by the user (for example, command 3 sends the values of PV, SV, TV and QV, when available);
- Burst mode: once all the above parameters have been configured, activate Burst mode.
- Acquisition based on Burst time: parameter that reduces equipment consumption by making only one acquisition immediately before the Burst transmission. If this parameter is disabled, the equipment will make an acquisition every two seconds, regardless of the Minimum Burst Time.

j. After some negotiation time with the gateway, the device will begin to publish the configured command at a minimum configured time rate. The ACK icon is shown on the display (if available) when the device enters Burst mode and the F (t) icon flashes when the Burst command is sent (see section - Status indication on the display).

ATTENTION

The Burst mode settings will remain even after the device is turned off. After turned on, the device will automatically connect to the network in Burst mode with the same configured time and command. The higher the refresh rate, the shorter the battery life and vice versa. Set a refresh rate which allows the device keep running for a few years.

k. After the general configuration of the network, wait a period of about 1 hour for the network to start operating in a 100% optimized way. Attention: There is a parameter for estimating battery life that indicates the expected life, in days, of the equipment. This parameter is recalculated every 60 minutes and its value should only become valid after two or three hours of operation of the device on the network (time needed to optimize consumption). When this value is close to the end, the user will receive an alarm on the device status and on the display (when available). When replacing the Battery Module (Smar code 400-1273), the replacement must be configured using a configurator that will cause the equipment to reset the estimated lifetime count for the new module. (Search for "Battery Life Remaining").

ATTENTION: do not dispose the Battery Module in ordinary waste. Use a suitable disposal for batteries or chemical waste.

Checking Equipment Range

Identify what distance may be considered according the kind of environment where the device is installed:

- Strong obstruction - about 30 meters. Very dense environments in relation to the device, pipes, cables, etc. A place where you would normally are not able to walk.
- Medium obstruction - about 75 meters. Environments where devices are located in a good distance from others equipments in the factory floor.
- Light obstruction - 150 meters. Consider an open environment that has some kind of obstruction like a silo or a tank. There is plenty of free space around for RF waves to propagate.
- No obstruction - up to 225 meters. Consider that the antenna of the device "sees" directly the antenna of other devices or gateway in the network, without any obstacle between them. In addition, the difference in height between them should not cause an angle greater than 5 degrees.

Conditions that significantly reduce the range of the device include mounting the equipment close to the ground, below ground level or under water, as the RF signal is absorbed by the ground or water and does not propagate. In addition, mounting the equipment outside the network area (gateway), for example, considering a network in an open environment, installing the equipment inside a closed room also contributes to signal attenuation, after all the signal will not propagate very well under concrete, wood, etc.

Gateway commissioning

Gateways can have a remote antenna connection, allowing them to be installed indoors and only the antenna installed outdoor.

- a. Make sure that the gateway is available to the host system;
- b. Check the gateway and make sure that it has at least five (05) devices directly connected to it;
- c. Check that 25% of the devices are connected directly to the gateway. If necessary, add repeaters;
- d. The gateway connects the devices to the host system. Therefore, check that the device data is reaching the applications that subscribe to it.

INSTALLATION FLOWCHART

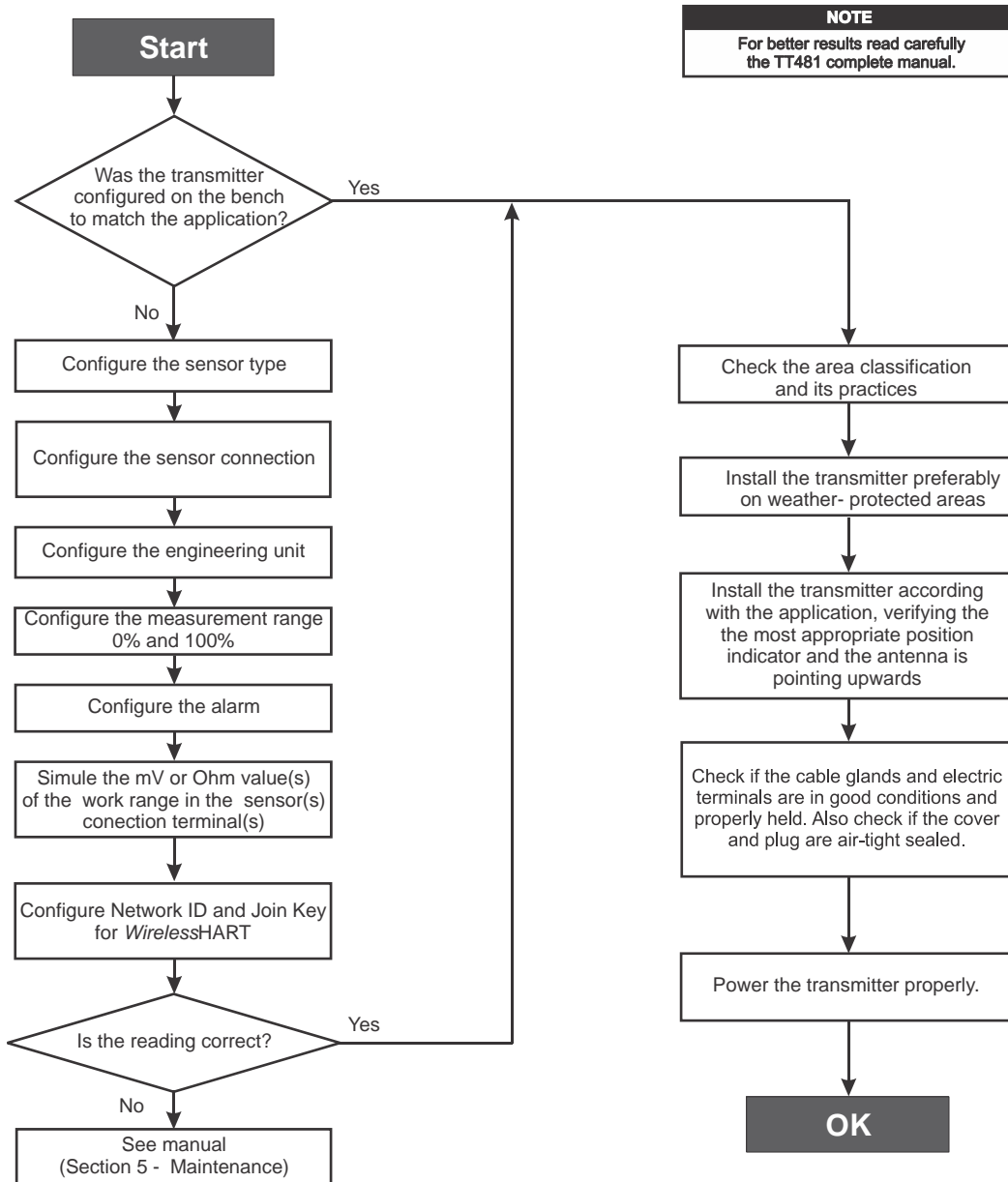

INSTALLATION

General

The overall accuracy of temperature and other measurements depends on several variables. Although the transmitter has an outstanding performance, proper installation is essential, in order to maximize its performance.

Among all factors, which may affect transmitter accuracy, environmental conditions are the most difficult to control. There are, however, ways of reducing the effects of temperature, humidity and vibration.

Temperature fluctuation effects can be minimized by locating the transmitter in areas protected from extreme environmental changes.

In warm environments, the transmitter should be installed to avoid, as much as possible, direct exposure to the sun. Installation close to lines and vessels subjected to high temperatures should also be avoided. For temperature measurements, sensors with cooling-neck can be used or the sensor can be mounted separated from the transmitter housing.

Use of sunshades or heat shields to protect the transmitter from external heat sources should be considered, if necessary.

Humidity is fatal to electronic circuits. In areas subjected to high relative humidity, the O'Rings for the electronics cover must be correctly placed. Removal of the electronics cover in the field must be reduced to the minimum necessary, since each time it is removed the circuits are exposed to the humidity. The electronic circuit is protected by a humidity proof coating, but frequent exposures to humidity may affect the protection provided. It is also important to keep the covers tightened in place. Every time they are removed, the threads are exposed to corrosion, since these parts can not be protected by painting. Code-approved sealing methods on conduit entering the transmitter should be employed.

Measurement error can be decreased by connecting the sensor as close to the transmitter as possible and using proper wires (see Section 2, Operation).

WARNING

Random, frequent or common cause failures must not damage the equipment's work or result in death or serious injure, must not harm to the environment or equipment, and must not loss of equipment or production.

Electrical shock can result in serious injury.

Mounting

The transmitter may be mounted according to the Figure 1.1.

To access the electronic board, terminal block, battery and display module, open the cover of the gear box by unscrewing the four front screws.

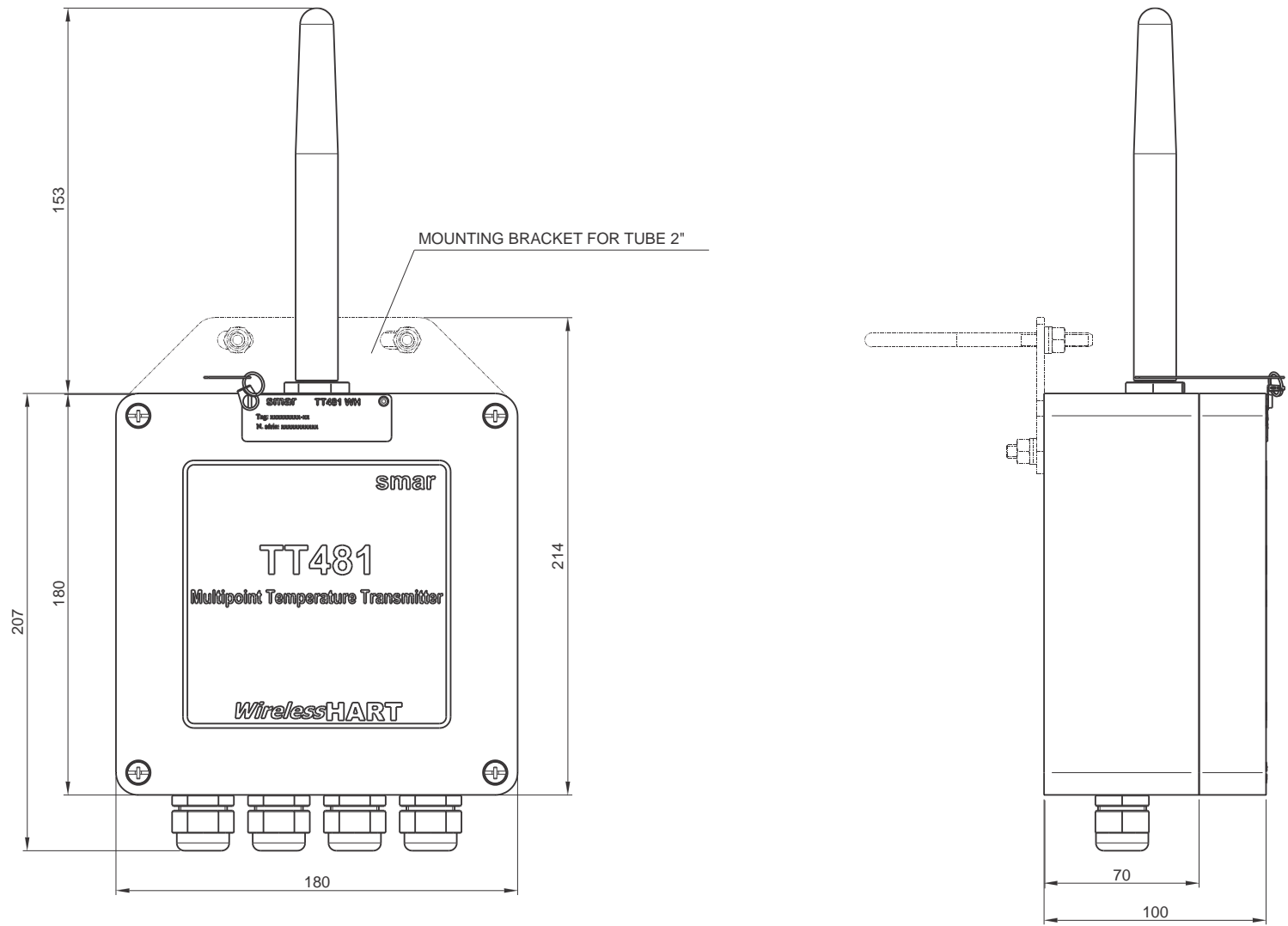

Figure 1.1 (a) – Dimensional Drawing - TT481 WirelessHART™ with 4 Channels

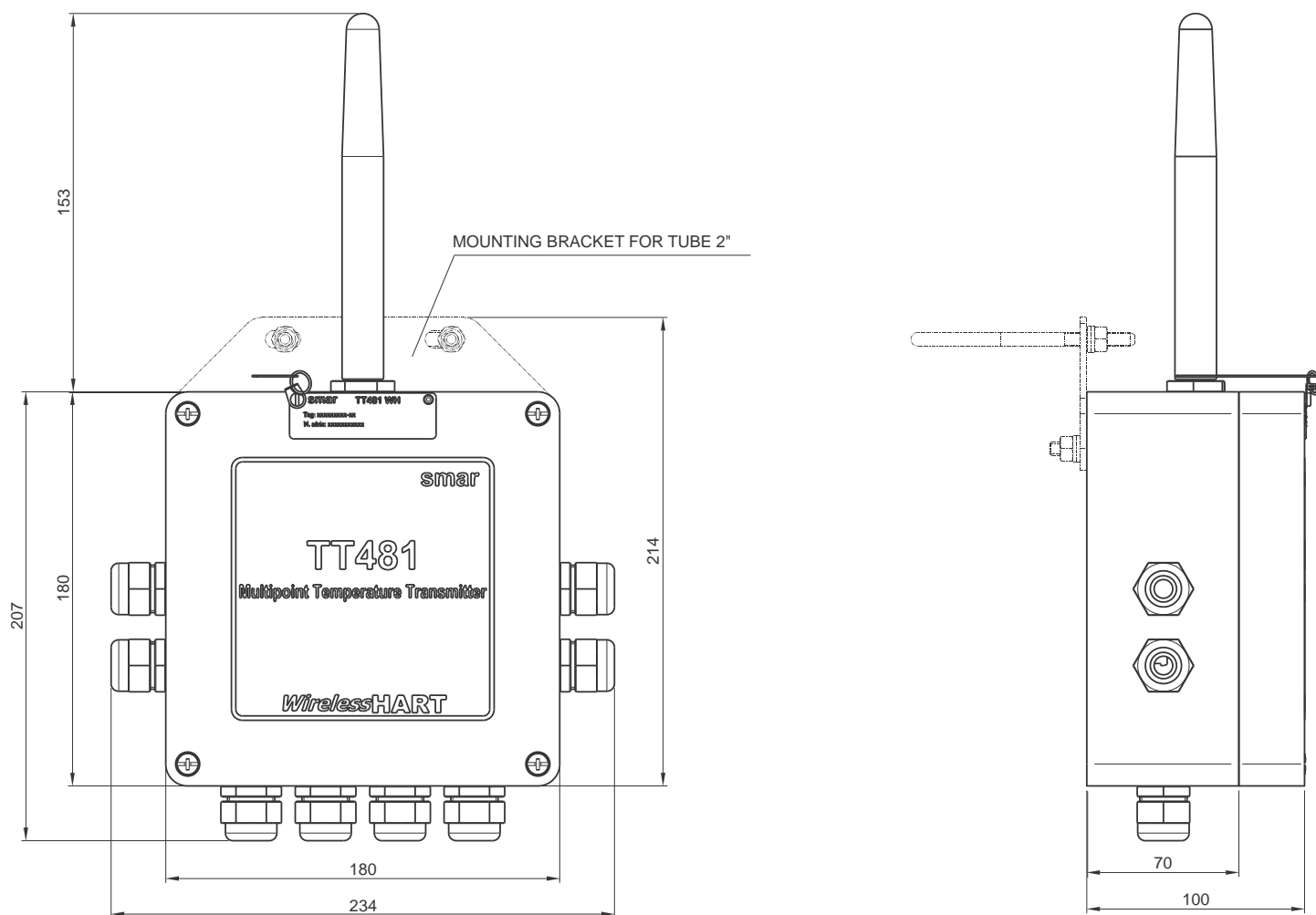

Figure 1.1 (b) – Dimensional Drawing - TT481 WirelessHART™ with 8 Channels

WARNING

The TT481 WirelessHART™ should always be installed with the antenna positioned upward.

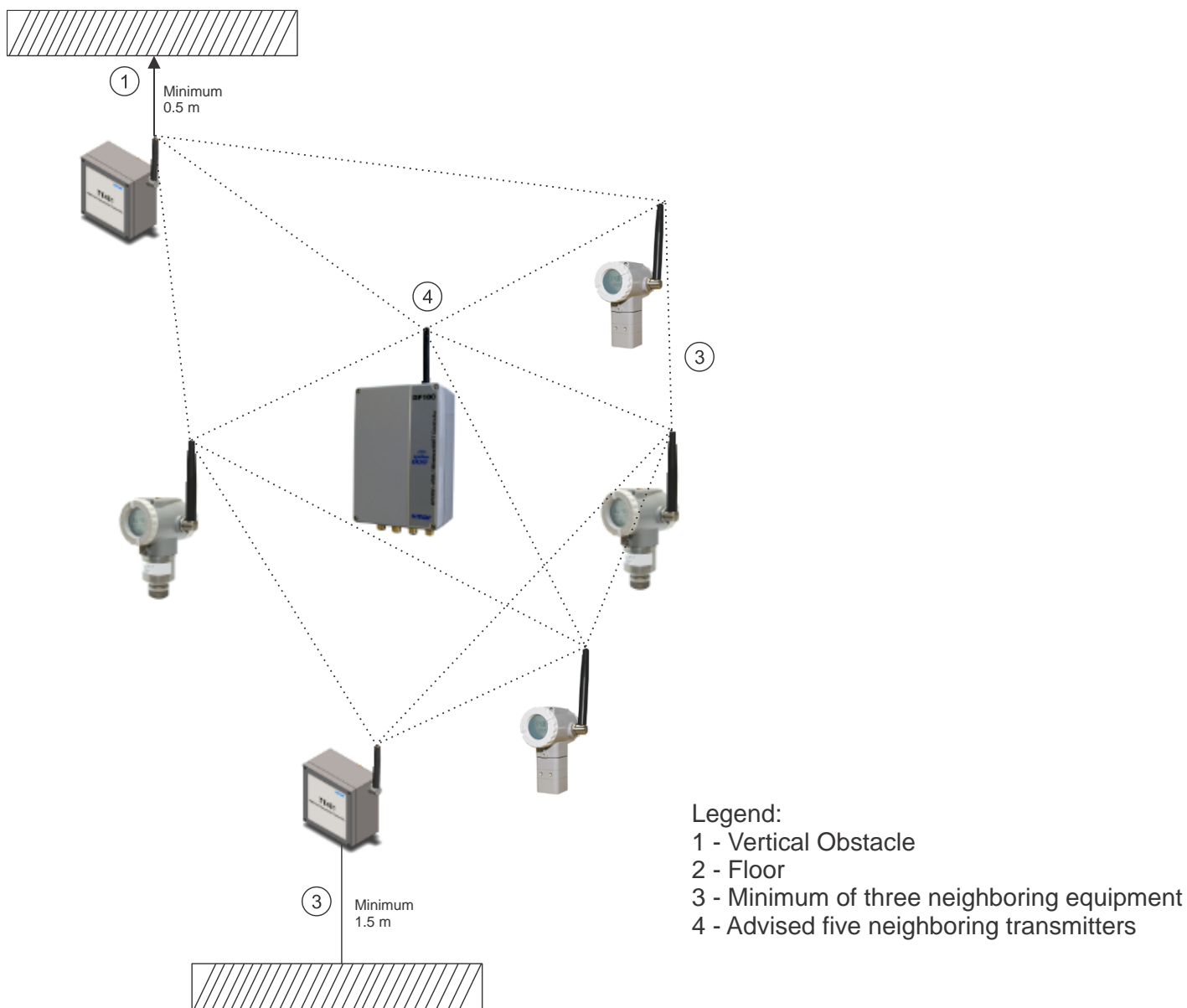

Figure 1.2 – Wiring Diagram for Wireless Transmitters

Battery Module Wiring

The device goes out of factory with battery module off, for safety and standard shipping. To turn it is necessary to previously connect the Battery Module connector to circuit board and flip the switch SW1 to the ON position (Figure 1.3).

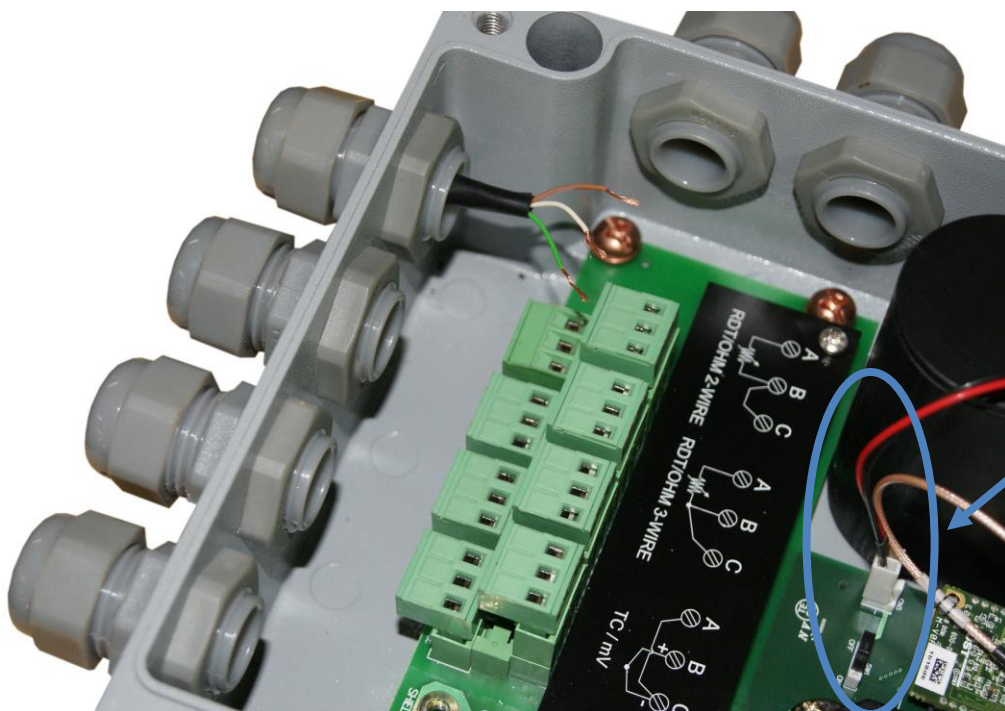

Figure 1.3 – Connecting the Battery Module to Electronic Board

The maintenance port allows initial configuration of the transmitter. To do this, it must connect a HART configurator in communication terminals "CN7" and "CN8", shown in Figure 1.4..



Figure 1.4 – Maintenance Port

The sensor connection on the input plate of the equipment shall be performed according to Figure 1.5, considering the type and number of sensors to be connected.

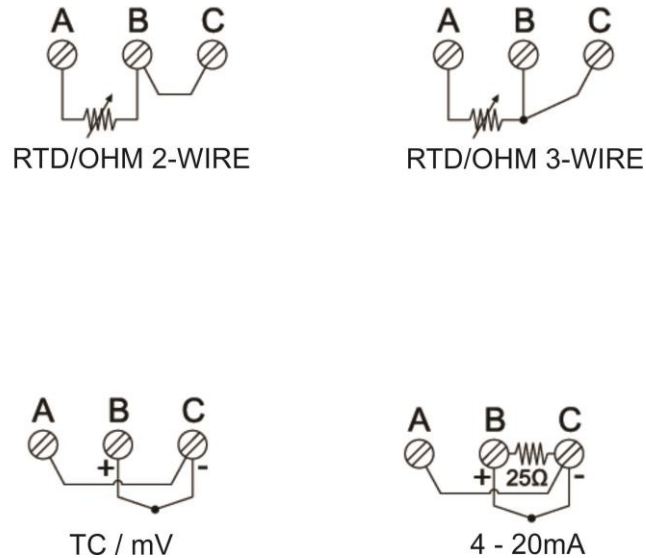

Figure 1.5 – Sensors Wiring

Installation in Hazardous Locations

WARNING

Explosions could result in death or serious injury, besides financial damage. Installation of this transmitter in explosive areas must be carried out in accordance with the local standards and the protection type adopted. Before continuing the installation make sure the certificate parameters are in accordance with the classified area where the equipment will be installed.

The instrument modification or parts replacement supplied by other than authorized representative of Smar is prohibited and will void the certification.

The transmitters are marked with options of the protection type. The certification is valid only when the protection type is indicated by the user. Once a particular type of protection is selected, any other type of protection can not be used.

Intrinsically Safe

WARNING

In hazardous zones with intrinsically safe or non-incendive requirements, the circuit entity parameters and applicable installation procedures must be observed.

For free access to the HART bus in the explosive environment, ensure the instruments in the loop are installed in accordance with intrinsically safe or non-incendive field wiring practices.

It is not recommended to remove the transmitter cover when the power is ON.

Section 2

OPERATION

The TT481 *WirelessHART*TM accepts signals from mV generators such as thermocouples or resistive sensors such as RTDs. The criterium is that the signal is within the range of the input. For mV, the range is -50 to 500 mV and for resistance, 0 to 2000 Ohm. For current the range is 4 to 20 mA.

Functional Description-Hardware

Refer to the block diagram (Figure 2.1). The function of each block is described below.

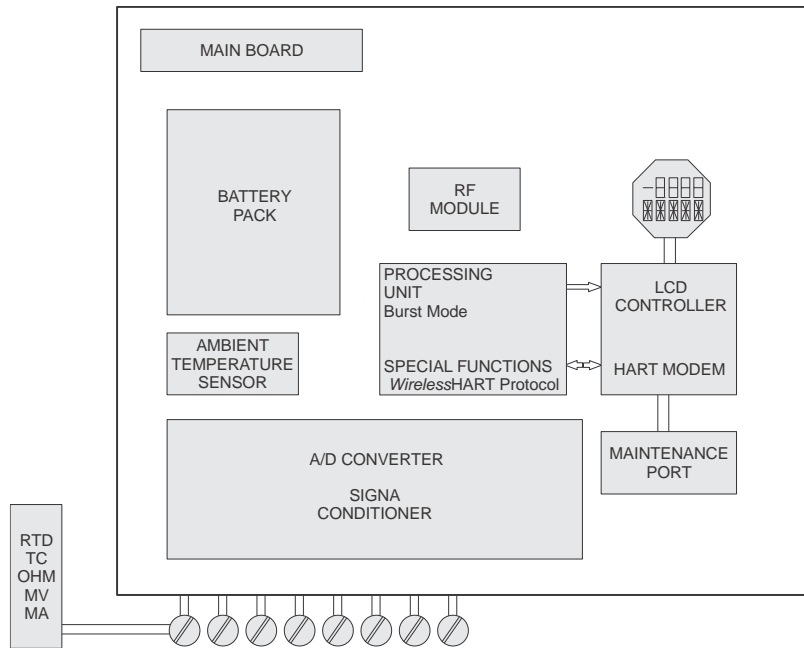

Figure 2.1 - TT481 *WirelessHART*TM Block Diagram

Input Signal Conditioner

A function to apply the correct gain to the input signals to make them suit the A/D converter.

A/D Converter

The A/D converts the input signal to a digital format for the CPU.

Processing Central Unit (CPU), RAM, FLASH and FRAM

The central processing unit (CPU) is the intelligent part of the transmitter responsible for the management and operation of measurement, execution block, self-test and communication. The program is stored in FLASH memory. For temporary storage of data, the CPU has an internal RAM. If you lose power, data stored in RAM is lost.

For data storage that requires persistence, such as configuration data, startup and aggregation, we use a non-volatile memory type FRAM for **TT400 *WirelessHART*TM**. It has an access time consistent with the RAMs normal and there is no limitation in terms of write cycles.

Modem

Modulates a communication signal in the current row. The "1" is represented by 1200 Hz and "0" for 2200 Hz. These signals are symmetrical and do not affect the continuous level signal 4-20 mA.

Battery

The Battery Module consists of 2 primary lithium batteries (Li-SOCI2) of 3.6 Volts, totaling 7.2 Volts. Each battery has 2.5 grams of lithium, totaling 5.0 grams Battery Module.

WARNING

By no means should be used other than the power supplied by batteries Module Smar (code 400-1273). When you replace the Battery Module (code Smar 400-1209) to set up the replacement via a configurator that will cause the device to reboot count the estimated lifespan for the new module.

Under normal use, the batteries offer no risk of spontaneous reaction if they are handled properly. You should exercise caution in relation to falls, high temperature and short-circuit the Battery Module, so that it does not offer any risk or malfunction.

Even with low batteries should keep the same care, they still offer dangers. Never attempt to disassemble, modify or recharge the batteries as this may result in leakage or explosion.

STORAGE - the battery module should preferably be stored in an environment below 30 ° C, dry, ventilated subject to less variation in temperature.

Do not dispose of batteries in Module trash. Use a battery for proper disposal or chemical waste.

When you replace the Battery Module (code Smar 400-1273) to set up the replacement via a configurator that will cause the device to reboot count the estimated lifespan for the new module.

For Additional Information and First Aid, see Appendix B - "Safety Datasheet Battery" or consult the manufacturer's website: <http://www.tadiranbat.com/index.php/shipping-and-information>.

Display Controller

Receives data informing the CPU that segments of Liquid Crystal Display must be connected.

Temperature Sensor

The **TT400 WirelessHART™**, as previously explained, accepts several types of sensors. The **TT400 WirelessHART™** is specially designed for temperature measurement using thermocouples or thermoresistances (RTDs).

Some basic concepts about these sensors are presented below.

THERMOCOUPLES

Thermocouples are the most widely used sensors in industrial temperature measurements.

Thermocouples consist of two wires made from different metals or alloys joined at one end, called measuring junction. The measuring junction should be placed at the point of measurement. The other end of the thermocouple is open and connected to the temperature transmitter. This point is called reference junction or cold junction.

For most applications, the Seebeck effect is sufficient to explain thermocouple behavior:

How the Thermocouple Works

When there is a temperature difference along a metal wire, a small electric potential, unique to every alloy, will occur. This phenomenon is called Seebeck effect.

When two wires of different metals are joined in one end, and left open in the other, a temperature difference between the two ends will result in a voltage since the potentials generated by the different materials are not the same and does not cancel each other out. Two important things must be noted. First: the voltage generated by the thermocouple is proportional to the difference between the measuring-junction and the cold junction temperatures. Therefore the temperature at the reference junction must be added to the temperature derived from the thermocouple output, in order to find the temperature measured. This is called cold junction compensation, and is done automatically by the **TT400 WirelessHART™**, which has a temperature sensor at the sensor terminals for this purpose. Secondly, if the thermocouple wires are not used all the way to the terminals of the transmitter (e.g. copper wire is used from sensor-head or marshalling box), new junctions with additional Seebeck effects will be created and ruin the measurement in most cases, since the cold-junction compensation will be done in the wrong point.

The relation between the measuring junction temperature and the generated millivoltage is tabulated in thermocouple calibration tables for standardized thermocouple types, the reference temperature being 0 °C.

Standardized thermocouples which are commercially used, whose tables are stored in the memory of the **TT400 WirelessHART™**, are the following:

- NBS (B, E, J, K, N, R, S e T)
- DIN (L, U)

THERMORESISTANCES (RTDs)

Resistance Temperature Detectors, most commonly known as RTD's, are based on the principle that the resistance of a metal increases as its temperature increases.

Standardized RTDs, whose tables are stored in the memory of the **TT400 WirelessHART™**, are the following:

- JIS [1604-81] (Pt50 e Pt100)
- IEC, DIN, JIS [1604-89] (Pt50, Pt100, Pt500 e Pt1000)
- GE (Cu 10)
- DIN (Ni 120)

For a correct measurement of RTD temperature, it is necessary to eliminate the effect of the resistance of the wires connecting the sensor to the measuring circuit. In some industrial applications, these wires may be hundreds of meters long. This is particularly important at locations where the ambient temperature changes a lot.

A 2-wire connection may cause measuring errors. It will depend on the length of connections wires and on the temperature to which they are exposed (see Figure 2.2).

In a 2-wire connection, the voltage V2 is proportional to the RTD resistance plus the resistance of the wires.

$$V2 = [RTD + 2x R] x I$$

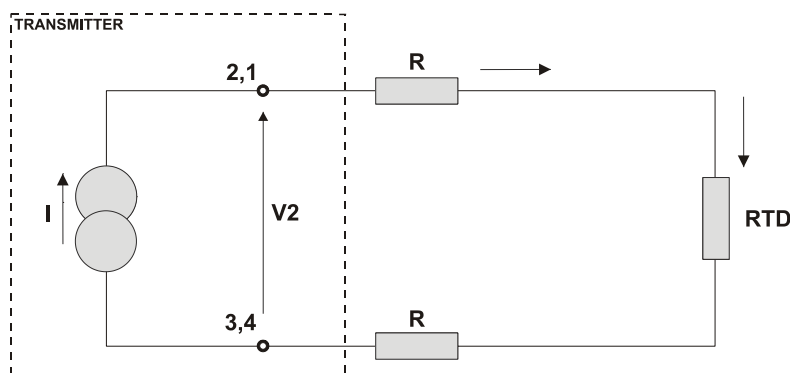

Figure 2.2 – Two-Wire Connection

In order to avoid the resistance effect of the connection wires, it is recommended to use a 3-wire connection (see Figure 2.3).

In a 3-wire connection, terminal 3 is a high impedance input. Thus, no current flows through that wire and no voltage drop is caused. The voltage V2-V1 is independent of the wire resistances since they will be canceled out, and is directly proportional to the RTD resistance alone.

$$V2-V1 = [RTD + R] x I - R x I = RTD x I$$

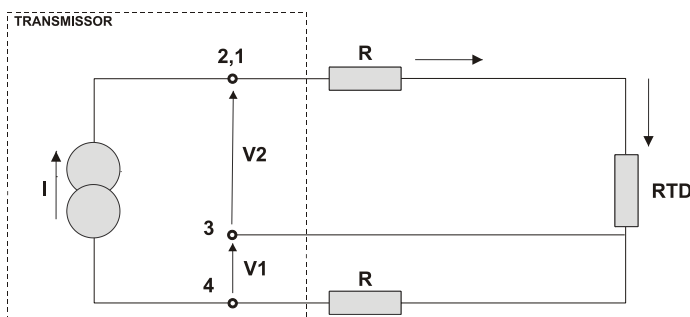

Figure 2.3 – Three-Wire Connection

A differential connection is similar to the two-wire connection and gives the same problem (see Figure 2.4). The resistance of the other two wires will be measured and does not cancel each other out in a temperature measurement, since linearization will affect them differently.

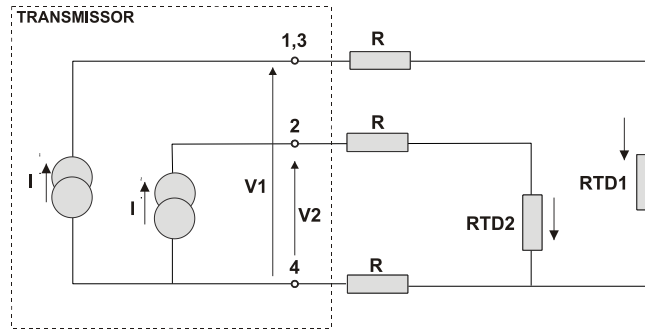

Figure 2.4 – Differential Connection

NOTE

The material the gauge and the length should be the same connections of 3 threads.

CURRENTS (4 to 20mA)

It can measure current by connecting a shunt resistor of 25 Ohms between terminals 2 and 3, according to the wiring diagram of the sensor in Figure 1.5.

The Display

The digital indicator is able to display one or two variables which are user selectable. When two variables are chosen, the display will alternate between the two with an interval of 3 seconds.

The display indicates engineering units, values and parameters simultaneously with most status indicators. The monitoring mode indication is interrupted in case of an alarm been activated.

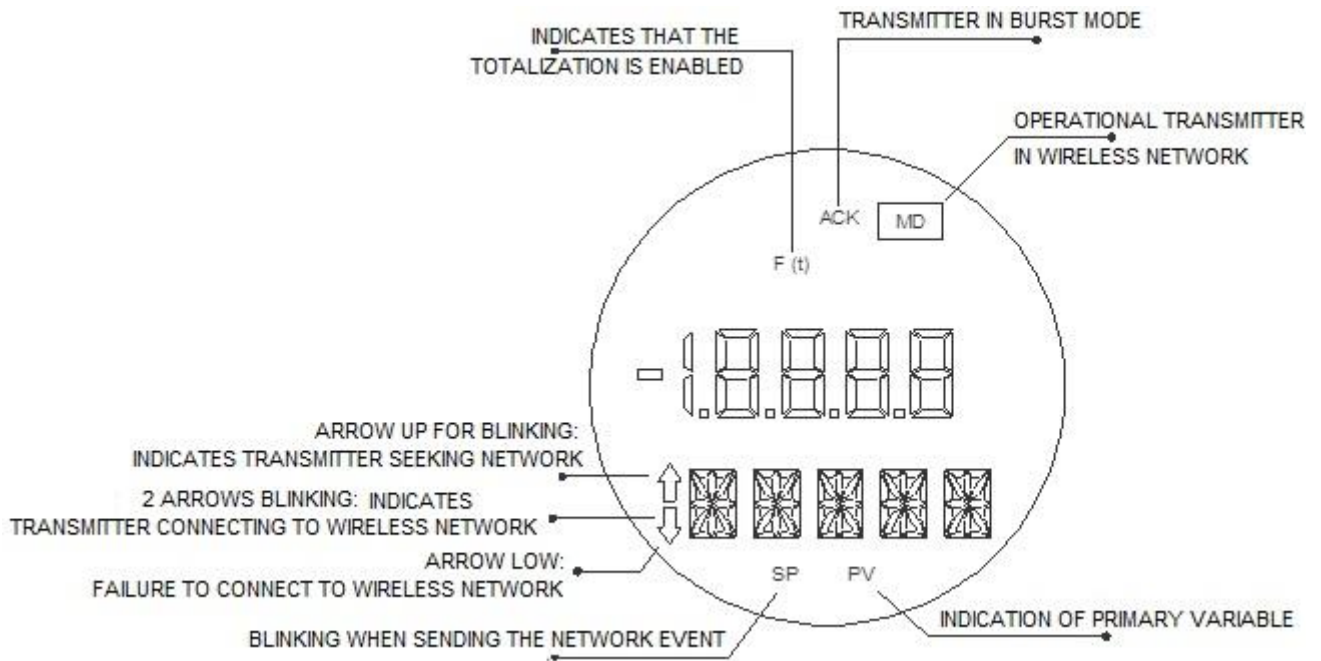

Figure 2.5 – Typical Monitoring Mode Display

Writing Protection

The write protection function can be activated by two means: hardware (switch on the main board) and software. The writing of any parameter is possible only if both guards are disabled.

Another way to protect the writing, but in a partial way, is the Hardware Lock option (Lock Device for *WirelessHART*[®]).

This option is used in *WirelessHART*[®] device to block writing to only a means of setting: Maintenance port or gateway. Thus, it avoids concurrency settings, and consequently dangerous situations.

The locking types are:

- Unlocked: both setters have write permission;
- Locked out: only configurator that locked the equipment has write permission. However, after rebooting the machine state back to Unlocked.
- Permanently locked: only configurator that crashed the machine writable and this state remains even after rebooting the machine.
- All locked: no configurator writable until the equipment is unlocked by the same configurator that caught.

WARNING

The use of this function should be used only on special occasions, where the written assurance of the parameter is critical and fast. After this, the user must return the equipment to the Unlocked mode.

Section 3

MAINTENANCE

General

All servicing of Smar transmitters must be done by a qualified person and exchange of components (provided by Smar) must be made only by individuals certified to do so.

Diagnostics with the Display

The display can show failure messages in the alphanumeric segment. These messages are shown in Table 3.1.

MENSAGENS DE DIAGNÓSTICO	FONTE POTENCIAL DE PROBLEMA
FAIL RADIO	Indicate problems on the radio.
LOW BATT	Indicate battey with low level.
FAIL BATT	Indicate battey with critical level.
PVbad	Indicate error in the sensor measurement.
Tbad	Indicate error in the ambiente temperature measurement

Table 3.1 – Diagnóstico with Display

Problems and Solutions

Equipment does not connect to the *WirelessHART™* network

Possible causes:

- The equipment is off;
- Network/Gateway manager is off;
- The equipment is far from the Network/Gateway Manager or other equipment connected to the same;
- Safety key (Join Key) and Access key (Network Id) are not configured correctly;
- The antenna is not connected in the Network/Gateway Manager or in the equipment;
- There is a Access Control List in the Network/Gateway Manager and the device is not on this list;
- Maximum number of equipment configured in the Network/Gateway Manager was reached.

Equipment disconnecting and connecting to the network continuously to the *WirelessHART™* network

Possible causes:

- Low battery or bad contact in the power causing the restart of equipment;
- The connectivity in relation to neighbors is unstable (mobile obstacles or distance in the limit);

Equipment are within the operating range, but the communication stability is not good

Possible cause:

- Interference. Bring the equipment to obtain a better stability.

Disassembly Procedure

WARNING
This operation type must be done in a safety área and with the transmitter no energized.

Figure 3.1 indicate the componentes position mentioned in this description.

Antenna

If necessary disassembly the antenna set, it is ESSENTIAL to remove the cover device to disconnect the cable from the antenna circuit board.







	
<p>a) Remove the front screws (2) from the gear box cover.</p>	<p>b) Remove cover (1) of the device.</p>
	
<p>c) Make sure that the device is turned off and unplug the power cable from the battery.</p>	<p>d) Disconnect the antenna cable (9) radio and drop the thread of the antenna assembly to disassemble it.</p>
	
<p>e) With the aid of a screwdriver, loosen all connections of sensors in each of up to eight entries.</p>	<p>f) Remove the sensor cables for cable glands (7).</p>
	
<p>g) With the aid of an Allen wrench, loosen the set screw (12) Module Batteries (13) and pull it out of the box.</p>	<p>h) Remove the screws (5) Equipment (6) board to hold the box board.</p>

Table 3.2 – Rapid Procedure Removing the Transmitter

WARNING
The board has CMOS components which may be damaged by electrostatic discharges. Observe correct procedures for handling CMOS components. It is also recommended to store the circuit boards in electrostatic-proof cases.

Reassembly Procedure

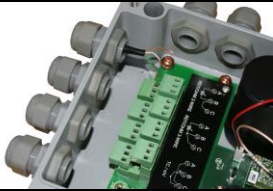
WARNING

This operation type must be done in a safety area and with the transmitter no energized.

Figure 3.1 shows the components position mentioned in this description.







	
<p>a) Attach the electronic board (6) to the box using their screws (5).</p>	<p>b) With the aid of an Allen wrench, attach the battery module (13) using screw (12).</p>
	
<p>c) Insert the sensor cables to be used by passing them by cable glands (7).</p>	<p>d) With the aid of a screwdriver, screw all sensor connections in each of up to eight entries.</p>
	
<p>e) Screw the antenna assembly and connect the antenna cable (9) to the radio connector.</p>	<p>f) Make sure that the sensors and antenna cable are securely connected.</p>
	
<p>g) g) Connect the power cable from the battery module to the electronic board. Switch on the machine and cover it with the lid (3).</p>	<p>h) Screw the housing cover using their screws (2).</p>

Table 3.3 – Quick Start Transmitter Mounting

Returning Materials

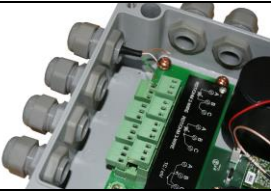
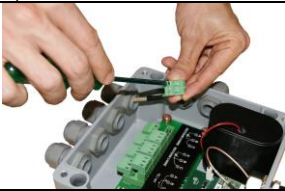
Should it become necessary to return the transmitter and/or configurator to SMAR, simply contact our office, informing the defective instrument serial number, and return it to our factory.

If it becomes necessary to return the transmitter and/or configurator to Smar, simply contact our office, informing the defective instrument's serial number, and return it to our factory. In order to speed up analysis and solution of the problem, the defective item should be returned with the Service Request Form (SRF – Appendix B) properly filled with a description of the failure observed and with as much details as possible. Other information concerning to the instrument operation, such as service and process conditions, is also helpful.

Instruments returned or to be revised outside the guarantee term should be accompanied by a purchase order or a quote request.

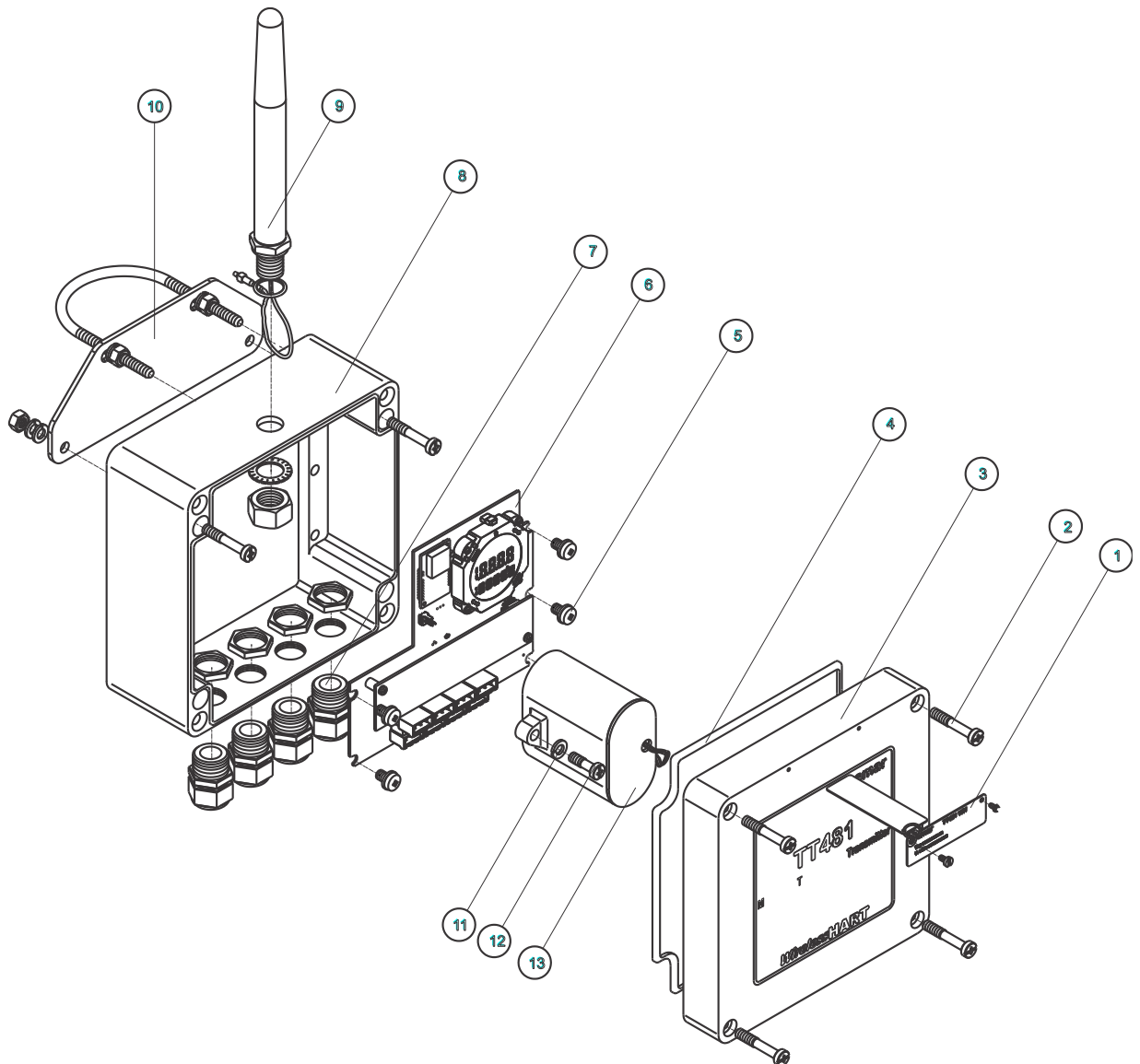

Figure 3.1 (a) – Exploded View - TT481 WirelessHART™ with 4 Channels

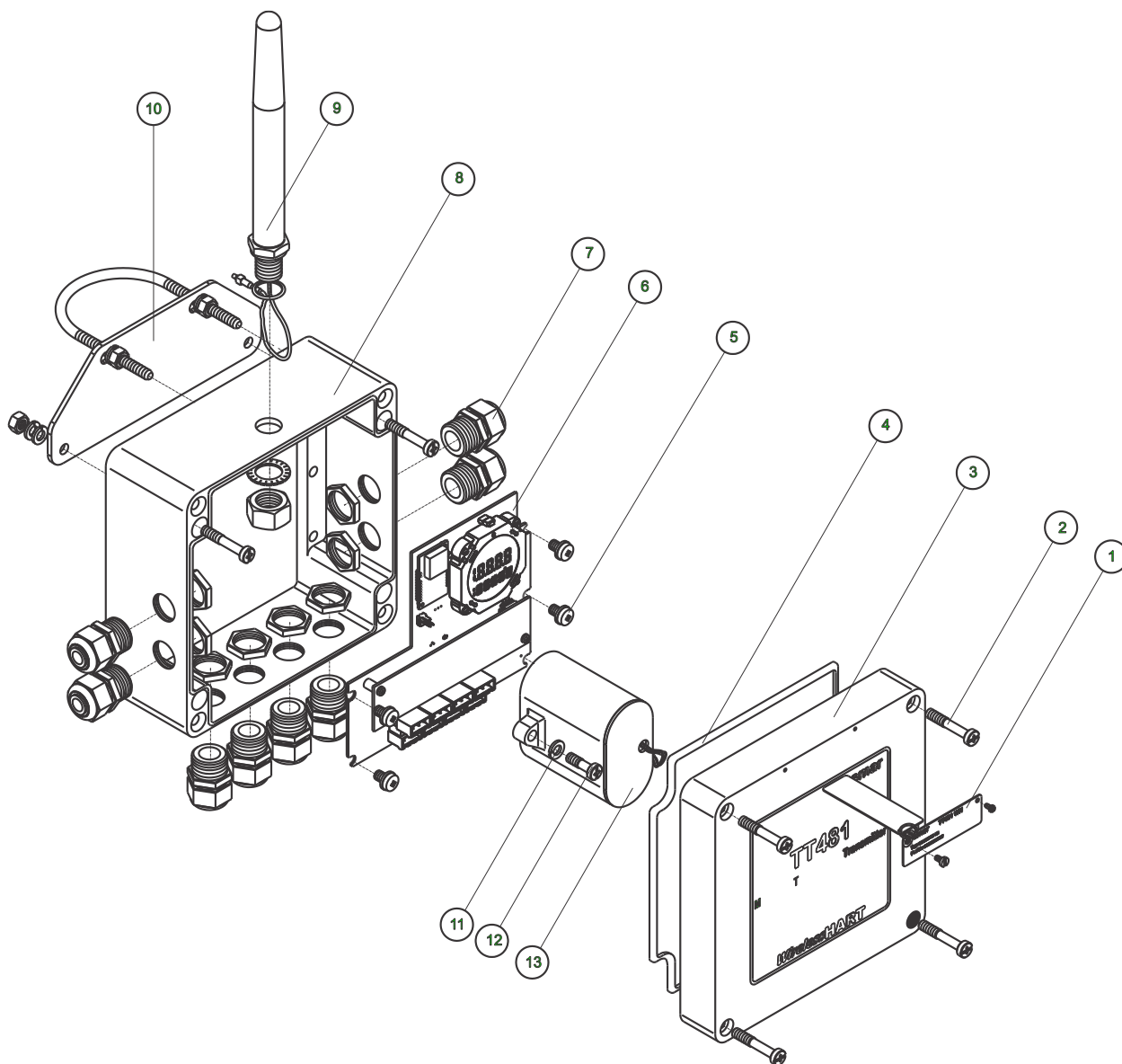

Figure 3.1 (b) – Exploded View - TT481 WirelessHART™ with 8 Channels

SPARE PARTS LIST FOR TRANSMITTER	
Parts	Code
Antenna	400-1258
Box with Cover - Option C4: 4 channels - Option C8: 8 channels	400-1268
Battery Pack	400-1273
Electronic Board GLL1428	400-1272
Cable Gland Kit	400-1269
Terminals (pack with 8 units)	400-1270
Box O'ring (pack with 5 units)	400-1271

Section 4

TECHNICAL CHARACTERISTICS

Functional Specifications	
Input	4 or 8 sensors (see tables 5.1, 5.2, 5.3 and 5.4).
Battery	The pack consists of 2 primary lithium batteries (Li-SOCl ₂) of 3.6 V, totaling 7.2 V. Battery Life: - Burst mode to 8s, @25 °C, network with at least 3 devices neighbor: 5 years PS: The module used batteries in the transmitters must be provided exclusively by Smar (PACK BATTERY - Code 400-1273).
Indicator	4 1/2 -digit numerical and 5-character alphanumeric LCD indicator (optional). Function and status icon. Indication of failure or saturation in sensor 1 display;
Communication Protocol	HART Protocol Version 7, with set of commands TT400 WirelessHART™ . A specific review of the HART transmitter must be managed according to the transmitter TT400 WirelessHART™ .
Measurement Type	Temperature with resistive or millivoltage sensor;; Electrical resistance; Millivoltage; Current 4-20mA.
Configuration	Remote configuration with external programmer via HART® Protocol, using DDL/EDDL;

Performance Specifications	
Accuracy	See Tables 4.1, 4.2 and 4.3.
Response Time	8 s to update all sensors.
Sensor Reading	Accuracy of A/D Converter: ±0.01% of the span.
Stabilization Time after the Power up – hot start up	Less than 17 seconds.

Physical Specifications	
Terminal Block	Four or eight terminals for sensor connection.
Mounting	Aluminium with electrostatic polyester painting; Accessories (bolts, nuts, washers and U-clamps) in carbon steel or 316 SST.
Weight	Up to 2,0 Kg without any optional part.
Identification Plate	316 SST plate with bounded special plastic label.

Transmitter Specifications	
Sensor Input Treatment	AD with 50 and 60 Hz input noise rejection; Input sensor trim; Ambient Temperature Trim.
Primary Variable Treatment	Engineering unit conversion; Cold junction compensation; Input Sensor characterization;

Protected Operation Specifications	
Configuration operation counter	Counting of the configuration change operations.
Configuration Protection	Configurations blocked by password; Write Protection via hardware and software;
Certification / Compliance to the standards	Intrinsic Safety (pending), Weather Proof.

Human Machine Interface Specifications

Indication of the state in the display	Item	Icon	Description
	1	PV	Primary Variable Sensor 1
	2	↑	Blinking when the transmitter is seeking wireless network
	3	↕	Blinking when connecting to the wireless network
	4	MD	Transmitter operating on the wireless network
	5	↓	Failed to connect to the wireless
	6	ACK	Transmitter in burst mode
	7	F(t)	Blinking when sending command in burst mode
	8	SP	Lights when an event is sent by the device to the wireless network

2 or 3 wires						
SENSOR	TYPE		RANGE °C	RANGE °F	MINIMUM SPAN °C	* DIGITAL ACCURACY °C
RTD	Cu10	GE	-20 to 250	-4 to 482	150	± 1.5
	Ni120	Edson Curve #7	-50 to 270	-58 to 518	20	± 0.2
	Pt50	IEC 751-83 (0,00385)	-200 to 850	-328 to 1562	40	± 0.32
	Pt100	IEC 751-83 (0,00385)	-200 to 850	-328 to 1562	40	± 0.3
	Pt500	IEC 751-83 (0,00385)	-200 to 450	-328 to 842	40	± 0.3
	Pt1000	IEC 751-83 (0,00385)	-200 to 300	-328 to 572	40	± 0.3
	Pt50	JIS 1604-81 (0,003916)	-200 to 600	-328 to 1112	40	± 0.32
	Pt100	JIS 1604-81 (0,003916)	-200 to 600	-328 to 1112	40	± 0.32
	Pt100	MILT-T24388C (0,00392)	-40 to 540	-40 to 1000	40	± 0.3
	Ni120	MILT-T24388C (0,00392)	-40 to 205	-40 to 400	20	± 0.25
	Pt100	IEC 751-95 (0,00385)	-200 to 850	-328 to 1562	10	± 0.3
	Pt100	GOST 6651-09 (0,003911)	-200 to 850	-328 to 1562	10	± 0.3
	Pt50	GOST 6651-09 (0,003911)	-200 to 850	-328 to 1562	10	± 0.3
	Cu100	GOST 6651-09 (0,003911)	-50 to 200	-58 to 392	10	± 0.25
Cu50	GOST 6651-09 (0,003911)	-50 to 200	-58 to 392	10	± 0.25	
TERMOPAR	B	NBS	100 to 1800	212 to 3272	50	± 1.5**
	E	NBS	-100 to 1000	-148 to 1832	20	± 0.3
	J	NBS	-150 to 750	-238 to 1382	30	± 0.4
	K	NBS	-200 to 1350	-328 to 2462	60	± 0.7
	N	NBS	-100 to 1300	-148 to 2372	50	± 0.6
	R	NBS	0 to 1750	32 to 3182	40	± 0.8
	S	NBS	0 to 1750	32 to 3182	40	± 1.0
	T	NBS	-200 to 400	-328 to 752	15	± 0.35
	L	DIN	-200 to 900	-328 to 1652	35	± 0.4
U	DIN	-200 to 600	-328 to 1112	50	± 0.5	

Table 4.1 – 2 or 3 wires Sensor Characteristics

*Reading accuracy on the display and accessed by communication.

**Not applicable for the first 20% of range (up to 440 °C).

SENSOR	RANGE mV	MINIMUM SPAN mV	* DIGITAL ACCURACY %
mV	-6 to 22	0.40	± 0.03% or ± 10 µV
	-10 to 100	2.00	± 0.03% or ± 20 µV
	-50 to 500	10.00	± 0.03% or ± 50 µV

Table 4.2 - mV Sensor Characteristics

SENSOR	RANGE Ohm	MINIMUM SPAN Ohm	* DIGITAL ACCURACY %
Ohm	0 to 100	3	± 0.03% or ± 0.05 Ohm
	0 to 400	12	± 0.03% or ± 0.08 Ohm
	0 to 2000	60	± 0.03% or ± 0.3 Ohm

Table 4.3 - Ohm Sensor Characteristics

SENSOR	RANGE mA	MINIMUM SPAN mA	* DIGITAL ACCURACY %
mA	4 to 20	4	± 0.1% or ± 4 µA

Table 4.4 - 4-20 mA Sensor Characteristics

*Reading accuracy on the display and accessed by communication.

**Not applicable for the first 20% of range (up to 440 °C).

NA Non applicable.

Ordering Code

MODEL	INTELLIGENT TEMPERATURE TRANSMITTER											
TT481	WirelessHART™											
	COD.	Channels Number										
	4	4 channels										
	8	8 channels										
	COD.	Telecommunication Certification										
	A	Certificate Anatel										
	COD.	Certification Type										
	N	Without Certification					I Ex-ia (Intrinsic Safe) (pending)					
	COD.	Organ Certifier										
	0	Without Organ Certifier										
	1	FM										
	5	CEPEL										
	COD.	Sensor Type (Sensor 1)										
	1	RTD Cu10 – GE			9 400 Ohm			H Thermocouple type S - NBS				
	2	RTD Ni120 – Edison Curve #7			A 2K Ohm			I Thermocouple type T - NBS				
	3	RTD Pt50 – IEC			B Thermocouple type B - NBS			J Thermocouple type L – DIN				
	4	RTD Pt100 – IEC			C Thermocouple type E - NBS			K Thermocouple type U – DIN				
	5	RTD Pt500 – IEC			D Thermocouple type J - NBS			L 22 mV				
	6	RTD Pt50 – JIS			E Thermocouple type K - NBS			M 100 mV				
	7	RTD Pt100 – JIS			F Thermocouple type N - NBS			N 500 mV				
	8	100 Ohm			G Thermocouple type R – NBS			O 4-20 mA				
	COD.	Sensor Connection (Sensor 1)										
	2	2 wires					3 3 wires					
	COD.	Sensor Type (Sensor 2)										
	1	RTD Cu10 – GE			9 400 Ohm			H Thermocouple type S - NBS				
	2	RTD Ni120 – Edison Curve #7			A 2K Ohm			I Thermocouple type T - NBS				
	3	RTD Pt50 – IEC			B Thermocouple type B - NBS			J Thermocouple type L – DIN				
	4	RTD Pt100 – IEC			C Thermocouple type E - NBS			K Thermocouple type U – DIN				
	5	RTD Pt500 – IEC			D Thermocouple type J - NBS			L 22 mV				
	6	RTD Pt50 – JIS			E Thermocouple type K - NBS			M 100 mV				
	7	RTD Pt100 – JIS			F Thermocouple type N - NBS			N 500 mV				
	8	100 Ohm			G Thermocouple type R – NBS			O 4-20 mA				
	COD.	Sensor Connection (Sensor 2)										
	2	2 wires					3 3 wires					
	COD.	Sensor Type (Sensor 3)										
	1	RTD Cu10 – GE			D Thermocouple type J - NBS							
	2	RTD Ni120 – Edison Curve #7			E Thermocouple type K - NBS							
	3	RTD Pt50 – IEC			F Thermocouple type N - NBS							
	4	RTD Pt100 – IEC			G Thermocouple type R – NBS							
	5	RTD Pt500 – IEC			H Thermocouple type S - NBS							
	6	RTD Pt50 – JIS			I Thermocouple type T - NBS							
	7	RTD Pt100 – JIS			J Thermocouple type L – DIN							
	8	100 Ohm			K Thermocouple type U – DIN							
	9	400 Ohm			L 22 mV							
	A	2K Ohm			M 100 mV							
	B	Thermocouple type B - NBS			N 500 mV							
	C	Thermocouple type E - NBS			O 4-20 mA							
	COD.	Sensor Connection (Sensor 3)										
	2	2 wires					3 3 wires					
	COD.	Sensor Type (Sensor 4)										
	1	RTD Cu10 – GE			D Thermocouple type J - NBS							
	2	RTD Ni120 – Edison Curve #7			E Thermocouple type K - NBS							
	3	RTD Pt50 – IEC			F Thermocouple type N - NBS							
	4	RTD Pt100 – IEC			G Thermocouple type R – NBS							
	5	RTD Pt500 – IEC			H Thermocouple type S - NBS							
	6	RTD Pt50 – JIS			I Thermocouple type T - NBS							
	7	RTD Pt100 – JIS			J Thermocouple type L – DIN							
	8	100 Ohm			K Thermocouple type U – DIN							
	9	400 Ohm			L 22 mV							
	A	2K Ohm			M 100 mV							
	B	Thermocouple type B - NBS			N 500 mV							
	C	Thermocouple type E - NBS			O 4-20 mA							
	COD.	Sensor Connection (Sensor 4)										
	2	2 wires					3 3 wires					
TT481	4	A	N	0	1	2	1	2	1	2	1	2

MODEL	INTELLIGENT TEMPERATURE TRANSMITTER (CONTINUATION)									
	COD. Sensor Type (Sensor 5) (Not applicable for option with 4 channels)									
	1	RTD Cu10 – GE	9	400 Ohm	H	Thermocouple type S - NBS				
	2	RTD Ni120 – Edison Curve #7	A	2K Ohm	I	Thermocouple type T - NBS				
	3	RTD Pt50 – IEC	B	Thermocouple type B - NBS	J	Thermocouple type L – DIN				
	4	RTD Pt100 – IEC	C	Thermocouple type E - NBS	K	Thermocouple type U – DIN				
	5	RTD Pt500 – IEC	D	Thermocouple type J - NBS	L	22 mV				
	6	RTD Pt50 – JIS	E	Thermocouple type K - NBS	M	100 mV				
	7	RTD Pt100 – JIS	F	Thermocouple type N - NBS	N	500 mV				
	8	100 Ohm	G	Thermocouple type R – NBS	O	4-20 mA				
	COD. Sensor Connection (Sensor 5) (Not applicable for option with 4 channels)									
	2	2 wires								
	3	3 wires								
	COD. Sensor Type (Sensor 6) (Not applicable for option with 4 channels)									
	1	RTD Cu10 – GE	9	400 Ohm	H	Thermocouple type S - NBS				
	2	RTD Ni120 – Edison Curve #7	A	2K Ohm	I	Thermocouple type T - NBS				
	3	RTD Pt50 – IEC	B	Thermocouple type B - NBS	J	Thermocouple type L – DIN				
	4	RTD Pt100 – IEC	C	Thermocouple type E - NBS	K	Thermocouple type U – DIN				
	5	RTD Pt500 – IEC	D	Thermocouple type J - NBS	L	22 mV				
	6	RTD Pt50 – JIS	E	Thermocouple type K - NBS	M	100 mV				
	7	RTD Pt100 – JIS	F	Thermocouple type N - NBS	N	500 mV				
	8	100 Ohm	G	Thermocouple type R – NBS	O	4-20 mA				
	COD. Sensor Connection (Sensor 6) (Not applicable for option with 4 channels)									
	2	2 wires								
	3	3 wires								
	COD. Sensor Type (Sensor 7) (Not applicable for option with 4 channels)									
	1	RTD Cu10 – GE	9	400 Ohm	H	Thermocouple type S - NBS				
	2	RTD Ni120 – Edison Curve #7	A	2K Ohm	I	Thermocouple type T - NBS				
	3	RTD Pt50 – IEC	B	Thermocouple type B - NBS	J	Thermocouple type L – DIN				
	4	RTD Pt100 – IEC	C	Thermocouple type E - NBS	K	Thermocouple type U – DIN				
	5	RTD Pt500 – IEC	D	Thermocouple type J - NBS	L	22 mV				
	6	RTD Pt50 – JIS	E	Thermocouple type K - NBS	M	100 mV				
	7	RTD Pt100 – JIS	F	Thermocouple type N - NBS	N	500 mV				
	8	100 Ohm	G	Thermocouple type R – NBS	O	4-20 mA				
	COD. Sensor Connection (Sensor 7) (Not applicable for option with 4 channels)									
	2	2 wires								
	3	3 wires								
	COD. Sensor Type (Sensor 8) (Not applicable for option with 4 channels)									
	1	RTD Cu10 – GE	9	400 Ohm	H	Thermocouple type S - NBS				
	2	RTD Ni120 – Edison Curve #7	A	2K Ohm	I	Thermocouple type T - NBS				
	3	RTD Pt50 – IEC	B	Thermocouple type B - NBS	J	Thermocouple type L – DIN				
	4	RTD Pt100 – IEC	C	Thermocouple type E - NBS	K	Thermocouple type U – DIN				
	5	RTD Pt500 – IEC	D	Thermocouple type J - NBS	L	22 mV				
	6	RTD Pt50 – JIS	E	Thermocouple type K - NBS	M	100 mV				
	7	RTD Pt100 – JIS	F	Thermocouple type N - NBS	N	500 mV				
	8	100 Ohm	G	Thermocouple type R – NBS	O	4-20 mA				
	COD. Sensor Connection (Sensor 8) (Not applicable for option with 4 channels)									
	2	2 wires								
	3	3 wires								
	COD. Tag Plate									
	0	With tag, when specified								
	1	Blank								
	2	User's specifications								
TT481	1	2	1	2	1	2	1	2	0	

Appendix A

		SRF – Service Request Form for Temperature Transmitter		Proposta No.: (1)	
Company:			Unit:		Receipt of Remittance:
COMMERCIAL CONTACT			CUSTOMER CONTACT		
Full name:			Full name:		
Position:			Position:		
Phone:		Extension:		Phone:	
Fax:		Extension:		Fax:	
Email:			Email:		
EQUIPMENT DATA					
Model:		Serial Number:		Firmware Version:	
Technology: <input type="checkbox"/> 4-20 mA <input type="checkbox"/> HART® <input type="checkbox"/> HART® SIS <input type="checkbox"/> WIRELESS HART® <input type="checkbox"/> ISP <input type="checkbox"/> FOUNDATION fieldbus™ <input type="checkbox"/> PROFIBUS PA					
PROCESS DATA					
Ambient Temperature (°C)		Work Temperature (°C)		Calibration Range	
Min:	Max:	Min:	Max:	Min:	Max:
Operation Time:			Failure Date:		
Sensor Type:					
Measurement type: <input type="checkbox"/> Double Sensor <input type="checkbox"/> Average between Sensors <input type="checkbox"/> Differential <input type="checkbox"/> Backup <input type="checkbox"/> Single				Application: (3) <input type="checkbox"/> Transmitter <input type="checkbox"/> Repeater	
FAILURE DESCRIPTION (Please, describe the behavior of the fail, if it is repetitive, how it exactly happens, and so on.)					
Did device detect the fail? (2) Yes <input type="checkbox"/> No <input type="checkbox"/>		What is the final value of the current? (2) _____ (mA)		Message showed in the display: (2)	
MAINTENANCE INFORMATION					
Did you allow the upgrade in the firmware? Yes <input type="checkbox"/> No <input type="checkbox"/>			Certification Plate: Will it maintained the certification? Yes <input type="checkbox"/> No <input type="checkbox"/>		
Main Board Configuration <input type="checkbox"/> Original Factory Configuration <input type="checkbox"/> Default Configuration <input type="checkbox"/> Special Configuration (Should be informed by the client. Please, use the space below)					
OBSERVATIONS					
SUBMITTER INFORMATION					
Company:					
Submitted by:		Title:		Section:	
Phone:		Extension:		E-mail:	
Date:			Signature:		
For warranty or non-warranty repair, please contact your representative. Further information about address and contacts can be found on www.smar.com/contactus.asp .					

NOTA	
(1) This field should be filled out by the Smar. (2) Required for SIS devices.	(3) Required for Wireless HART® devices.

BATTERY SAFETY DATASHEET

Section 1 – Identification

Manufacturer: Tadiran

Model: TL-5920

US office address: 2001 Marcus Avenue, Suite 125E, Lake Success, NY 11040

Emergency Telephone: 1-800-424-9300

Information Telephone: 1-516-621-4980

Section 2 – Composition

Ingredients	%
Lithium Metal (Li)	<5%
Thionyl Chloride (SOCl ₂)	<47%
Carbon (C)	<6%
Aluminum Chloride (AlCl ₃)	<5%
Lithium Chloride (LiCl)	<2%
Glass	<1%
PVC	<1%
PTFE	<1%
Steel, nickel and inherent components	balance

Section 3 – Hazard Identification

The batteries described herein are hermetically sealed and are not hazardous when used according to the manufacturer's recommendations.

Batteries should not be exposed to short-circuit, recharged, punched, burned, crushed, immersed in water, forced to discharge or placed in temperatures above the range specified for the product. In these cases there is a risk of fire and explosion.

Section 4 – First aid

In case of rupture, explosion or leakage, remove personnel from the contaminated area and ventilate it to release smoke, corrosive gases and odor. Seek medical help immediately.

Eyes - flush with plenty of water for at least 15 minutes (remove contact lenses if possible) and then seek medical attention.

Skin - Remove contaminated clothing and flush affected skin with plenty of water for 15 minutes and then seek medical attention.

Inhalation - look for an area with fresh air, rest, use artificial respiration, if necessary, and seek medical attention.

Ingestion - rinse your mouth, do NOT induce vomiting, drink lots of water, and then seek medical attention.

Section 5 – Fire fighting

If the batteries are directly involved in fire DO NOT USE: WATER, SAND, CO₂ and DRY CHEMICAL POWDER EXTINGUISHERS.

If the batteries are in a location adjacent to the fire, it can be combated according to the combustible material (paper or plastic, for example). In this case, the use of large quantities of cold water would be an effective way to combat.

To firefighting use equipment and protective clothing that prevent contact with battery solution. The fire must be fought at a safe distance and after evacuation of the area.

Batteries may explode when exposed to: excessive heat (above 150 °C), recharged, discharged below 0V, punched and crushed. Hydrogen Chloride (HCl) and sulfur dioxide (SO₂) can be formed during thermal decomposition of Cl₂.

Section 6 – Leakage

The material contained in the batteries will leak only if exposed to abusive conditions.

On the occasion of leakage: contain the leakage if using protective clothing and ventilate the area well. Cover with Sodium Carbonate (Na₂CO₃) and keep away from water, rain or snow. Put in a secure container and pour into proper trash, according to local regulatory standards.

Section 7 – Handling and storage

Never attempt to disassemble or modify the batteries as this may result in accident.

HANDLING – do not short-circuit the terminals or expose to temperatures above the range specified for the battery, overload, force discharge or thrown in fire. Do not punch, crush or immerse in water.

STORAGE – preferably store in an environment below 30 °C, dry and ventilated subject to less variation in temperature.

Do not store the batteries near heating equipment, nor expose to direct sunlight for long periods. Elevated temperatures may result in shortened batteries life and degrade their performance.

Do not store batteries in high humidity environment for long periods.

The batteries should not be recharged. High pressures can cause deformities and release of chemicals from the battery.

Ecological Information: When properly used or discarded, the batteries pose no danger to the environment. The batteries do not contain mercury, cadmium or lead. Do not let internal components exposed to the marine environment.

Disposal: Absolutely not incinerate batteries. Dispose of batteries according to local regulations.

Transportation: Batteries are considered "Dangerous Goods" when transported in or out of equipment.

For additional information, see the manufacturer's website
<http://www.tadiranbat.com/index.php/shipping-and-information>