

TT303

smar

AUG / 20
TT303
VERSION 3



**OPERATION & MAINTENANCE
INSTRUCTIONS MANUAL**

PROFIBUS PA TEMPERATURE TRANSMITTER

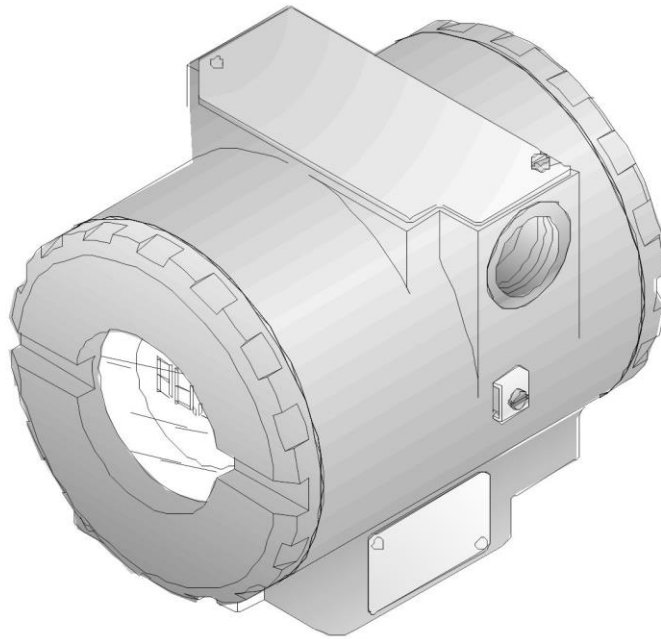

TT303ME

smar
NOVA SMAR S/A
www.smar.com.br

Specificatinos and information are subject to change without notice.
Up-to-date address information is available on our website.

web: www.smar.com/contactus.asp

INTRODUCTION

The **TT303** is from the first generation of Profibus PA devices. It is a transmitter mainly intended for measurement of temperature using RTDs or thermocouples, but can also accept other sensors with resistance or mV output such as: pyrometers, load cells, resistance position indicators, etc. The digital technology used in the **TT303** enables a single model to accept several types of sensors, an easy interface between the field and the control room and several others features that considerably reduces the installation, operation and maintenance costs.

The digital technology used in the **TT303** enables the choice of several types of transfer functions, an easy interface between the field and the control room and several interesting features that considerably reduce the installation, operation and maintenance costs.

The **TT303** is part of Smar's complete 303 line of Profibus-PA devices.

Some of the advantages of bi-directional digital communications are known from existing smart transmitter protocols: Higher accuracy, multi-variable access, remote configuration and diagnostics, and multi-dropping of several devices on a single pair of wires.

The system controls variable sampling, algorithm execution and communication so as to optimize the usage of the network, not losing time. Thus, high closed loop performance is achieved.

Using Profibus technology, with its capability to interconnect several devices, very large control schemes can be constructed. In order too be user friendly the function block concept was introduced.

The **TT303**, like the rest of the 303 family, has some Function Blocks built in, like Analog Input.

The need for implementation of Fieldbus in small as well as large systems was considered when developing the entire 303 line of Profibus-PA devices. They have common features and can be configured locally using a magnetic tool, eliminating the need for a configuration tool or console in many basic applications.

Now, thanks to Fieldbus, the transmitter accepts two channels, i.e., two measurements. This reduces the cost per channel. Other function blocks are also available. They allow flexibility in control strategy implementation.

Get the best result of the TT303 by carefully reading these instructions.

WARNING

In case of using Simatic PDM as the configuration and parameterization tool, Smar recommends that the user does not apply the option "Download to Device". This function can improperly configure the field device. Smar recommends that user make the use of the option "Download to PG / PC" and then selecting the Device Menu, use the menus of the transducer, function and display blocks acting specifically, according to each menu and method for reading and writing.

WARNING

This Manual is compatible with version 3.XX, where 3 note software version and XX software release. The indication 3.XX means that this manual is compatible with any release of software version 3.

Waiver of responsibility

The contents of this manual abides by the hardware and software used on the current equipment version. Eventually there may occur divergencies between this manual and the equipment. The information from this document are periodically reviewed and the necessary or identified corrections will be included in the following editions. Suggestions for their improvement are welcome.

Warning

For more objectivity and clarity, this manual does not contain all the detailed information on the product and, in addition, it does not cover every possible mounting, operation or maintenance cases.

Before installing and utilizing the equipment, check if the model of the acquired equipment complies with the technical requirements for the application. This checking is the user's responsibility.

If the user needs more information, or on the event of specific problems not specified or treated in this manual, the information should be sought from Smar. Furthermore, the user recognizes that the contents of this manual by no means modify past or present agreements, confirmation or judicial relationship, in whole or in part.

All of Smar's obligation result from the purchasing agreement signed between the parties, which includes the complete and sole valid warranty term. Contractual clauses related to the warranty are not limited nor extended by virtue of the technical information contained in this manual.

Only qualified personnel are allowed to participate in the activities of mounting, electrical connection, startup and maintenance of the equipment. Qualified personnel are understood to be the persons familiar with the mounting, electrical connection, startup and operation of the equipment or other similar apparatus that are technically fit for their work. Smar provides specific training to instruct and qualify such professionals. However, each country must comply with the local safety procedures, legal provisions and regulations for the mounting and operation of electrical installations, as well as with the laws and regulations on classified areas, such as intrinsic safety, explosion proof, increased safety and instrumented safety systems, among others.

The user is responsible for the incorrect or inadequate handling of equipments run with pneumatic or hydraulic pressure or, still, subject to corrosive, aggressive or combustible products, since their utilization may cause severe bodily harm and/or material damages.

The field equipment referred to in this manual, when acquired for classified or hazardous areas, has its certification void when having its parts replaced or interchanged without functional and approval tests by Smar or any of Smar authorized dealers, which are the competent companies for certifying that the equipment in its entirety meets the applicable standards and regulations. The same is true when converting the equipment of a communication protocol to another. In this case, it is necessary sending the equipment to Smar or any of its authorized dealer. Moreover, the certificates are different and the user is responsible for their correct use.

Always respect the instructions provided in the Manual. Smar is not responsible for any losses and/or damages resulting from the inadequate use of its equipments. It is the user's responsibility to know and apply the safety practices in his country.

TABLE OF CONTENTS

SECTION 1 - INSTALLATION	1.1
GENERAL	1.1
MOUNTING	1.1
NETWORK WIRING	1.1
SENSOR WIRING	1.4
TOPOLOGY AND NETWORK CONFIGURATION	1.6
INTRINSIC SAFETY BARRIER	1.7
JUMPER CONFIGURATION	1.7
POWER SUPPLY	1.7
INSTALLATION IN HAZARDOUS AREAS	1.8
EXPLOSION/FLAME PROOF	1.8
INTRINSICALLY SAFE	1.8
SECTION 2 - OPERATION	2.1
FUNCTIONAL DESCRIPTION - HARDWARE	2.1
TEMPERATURE SENSORS	2.2
THE DISPLAY	2.5
MONITORING	2.5
ALARM	2.6
SECTION 3 - CONFIGURATION	3.1
TRANSDUCER BLOCK	3.1
HOW TO CONFIGURE A TRANSDUCER BLOCK	3.1
FUNCTIONAL DIAGRAM OF THE TEMPERATURE TRANSDUCER BLOCK	3.2
TEMPERATURE TRANSDUCER BLOCK GENERAL PARAMETER DESCRIPTION	3.2
TEMPERATURE TRANSDUCER BLOCK GENERAL PARAMETER ATTRIBUTES	3.5
TT303 - CYCLIC CONFIGURATION	3.6
SENSOR TRANSDUCER NUMBER	3.10
JUMPER CONFIGURATION	3.11
HOW TO CONNECT TWO SENSORS	3.12
COMPENSATION OF LINE RESISTANCE FOR RTD DOUBLE SENSOR OR OHM SENSOR	3.12
COMPENSATION OF COLD JUNCTION	3.12
CALIBRATION IN TT303 BY THE USER	3.12
HOW TO CONFIGURE THE ANALOG INPUT BLOCK	3.14
PROGRAMMING USING LOCAL ADJUSTMENT	3.17
LOCAL ADJUSTMENT TREE - QUICK GUIDE	3.19
J1 JUMPER CONNECTIONS	3.20
W1 JUMPER CONNECTIONS	3.20
LOCAL PROGRAMMING TREE	3.20
TRANSDUCER DISPLAY – CONFIGURATION	3.22
DISPLAY TRANSDUCER BLOCK	3.23
DEFINITION OF PARAMETERS AND VALUES	3.24
SECTION 4 - MAINTENANCE PROCEDURES	4.1
TROUBLESHOOTING	4.1
DISASSEMBLY PROCEDURE	4.2
SENSOR	4.2
ELECTRONIC CIRCUITS	4.2
REASSEMBLE PROCEDURE	4.2
INTERCHANGEABILITY	4.2
RETURNING MATERIALS	4.3
SECTION 5 - TECHNICAL CHARACTERISTIC	5.1
ORDERING CODE	5.4
APPENDIX A - CERTIFICATIONS INFORMATION	A.1
APPENDIX B – SRF – SERVICE REQUEST FORM	B.1

Installation Flowchart

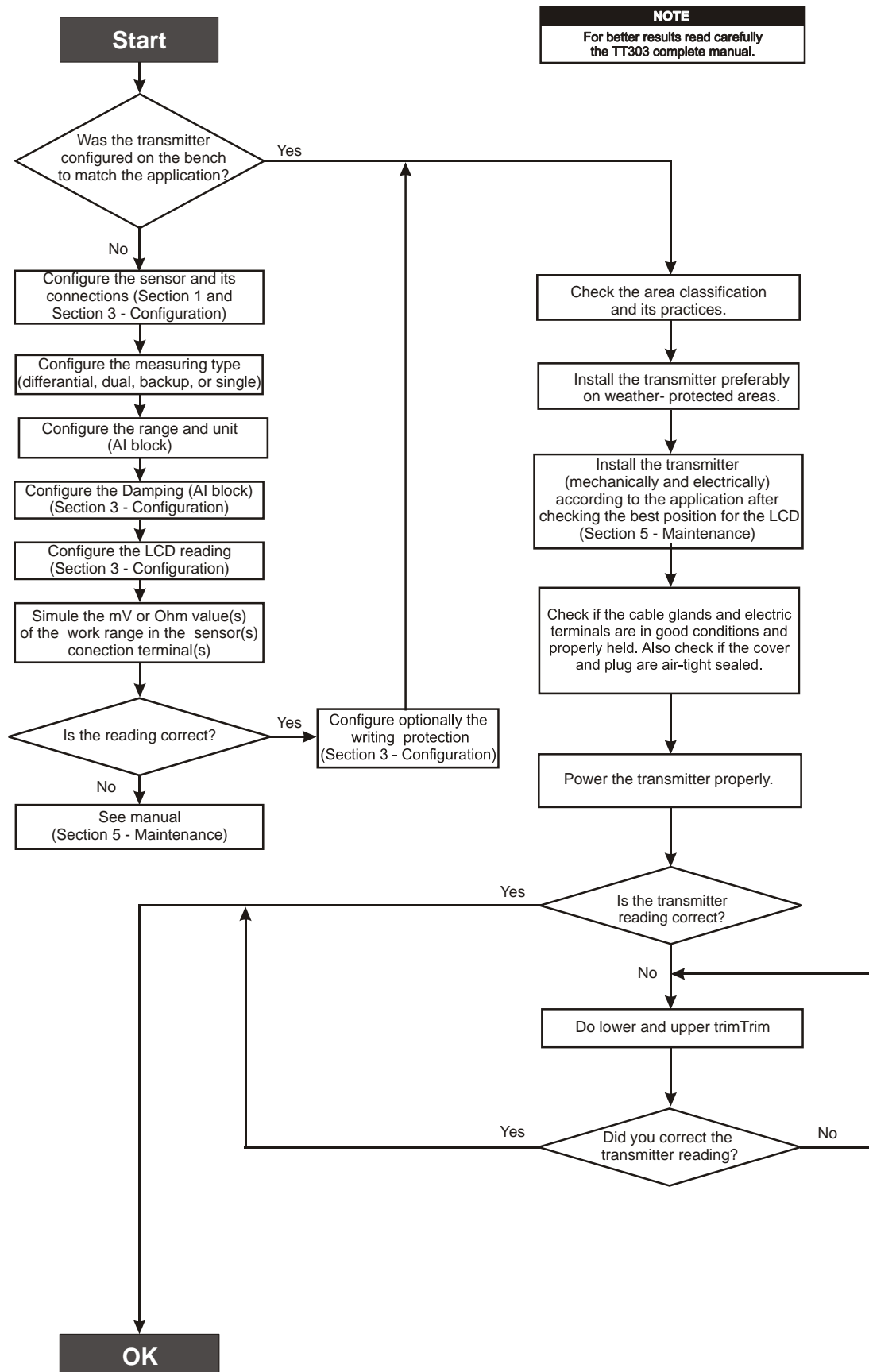

Section 1

INSTALLATION

General

The overall accuracy of temperature and other measurements depends on several variables. Although the transmitter has an outstanding performance, proper installation is essential in order to maximize its performance.

Among all factors which may affect transmitter accuracy, environmental conditions are the most difficult to control. There are, however, ways of reducing the effects of temperature, humidity and vibration.

Locating the transmitter in areas protected from extreme environmental changes can minimize temperature fluctuation effects.

In warm environments, the transmitter should be installed in such a way as to avoid, as much as possible, direct exposure to the sun. Installation close to lines and vessels subjected to high temperatures should also be avoided. For temperature measurements, sensors with cooling-neck can be used or the sensor can be mounted separately from the transmitter housing.

Use of sunshades or heat shields to protect the transmitter from external heat sources should be considered.

Humidity is fatal for electronic circuits. In areas subjected to high relative humidity, the O-rings for the electronic housing covers must be correctly placed and the covers must be completely closed by tightening them by hand until you feel the O-rings being compressed. Do not use tools to close the covers. Removal of the electronics cover in the field should be reduced to the minimum necessary, since each time it is removed, the circuits are exposed to humidity. The electronic circuit is protected by a humidity proof coating, but frequent exposure to humidity may affect the protection provided. It is also important to keep the covers tightened in place. Every time they are removed, the threads are exposed to corrosion, as painting cannot protect these parts. Code-approved sealing methods should be employed on conduit entering the transmitter.

Connecting the sensor as close to the transmitter as possible and using proper wires (See Section 2 - Operation), can decrease measurement error.

Mounting

The transmitter may be mounted in two basic ways:

- Separated from the sensor, using optional mounting brackets.
- Mounted on the sensor assembly.

It can be mounted in several different positions using the bracket, as shown in Figure 1.3. As shown in Figure 1.3 one of the conduit inlets for electrical connection is used to mount the sensor integral to the temperature transmitter.

For better visibility, the digital display may be rotated in steps of 90° (see Figure 4.1).

Network Wiring

Access the terminal block by removing the Electrical Connection Cover. This cover can be locked closed by the cover locking screw (See Figure 1.1). To release the cover, rotate the locking screw clockwise.

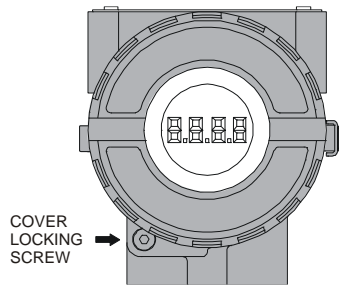

Figure 1.1 - Cover Locking

Cable access to wiring connections are obtained by one of the two conduit outlets. Conduit threads should be sealed by means of code-approved sealing methods. **The unused outlet connection should be plugged accordingly.**

The wiring block has screws on which fork or ring type terminals can be fastened (see Figure 1.2).

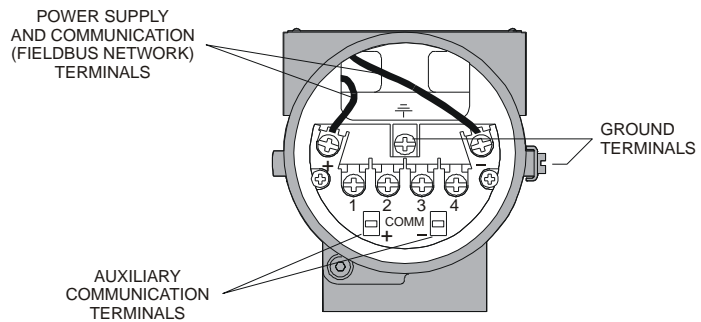

Figure 1.2 - Ground Terminals

For convenience, there are three ground terminals: one inside the cover and two externally, located close to the conduit entries.

WARNING

Do not connect the Fieldbus network wires to the sensor terminals. (Terminals 1, 2, 3 and 4).

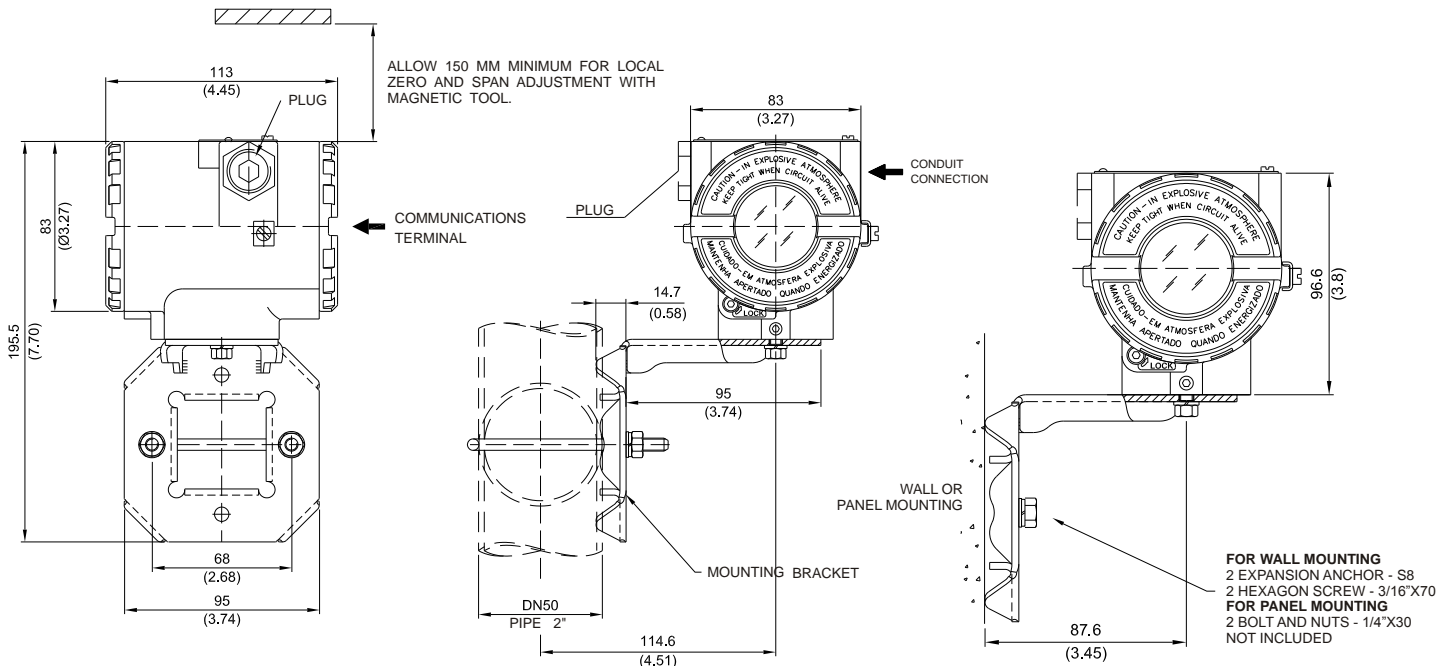

Figure 1.3 - Dimensional Drawing and Mounting Positions

The **TT303** uses the 31.25-kbit/s, voltage mode option for the physical signaling. All other devices on the same bus must use the same signaling. All devices are connected in parallel along the same pair of wires.

Various types of Fieldbus devices may be connected on the same bus. The **TT303** is powered via the bus. The limit for such devices is according to the DP/PA coupler limitations for one bus for non-intrinsically safe requirement.

In hazardous areas, the number of devices may be limited intrinsically safe restrictions, according to the DP/PA coupler and barriers limitations.

The **TT303** is protected against reverse polarity, and can withstand ± 35 VDC without damage, but it will not operate when in reverse polarity.

Use of twisted pair cables is recommended. It is also recommended to ground shield of shielded cables at one end only. The non-grounded end must be carefully isolated.

NOTE

Please refer to the General Installation, Operation and Maintenance Procedures Manual for more details.

The Figure 1.4 shows the correct installation of the conduit, in order to avoid penetration of water, or other substance, which may cause malfunctioning of the equipment.

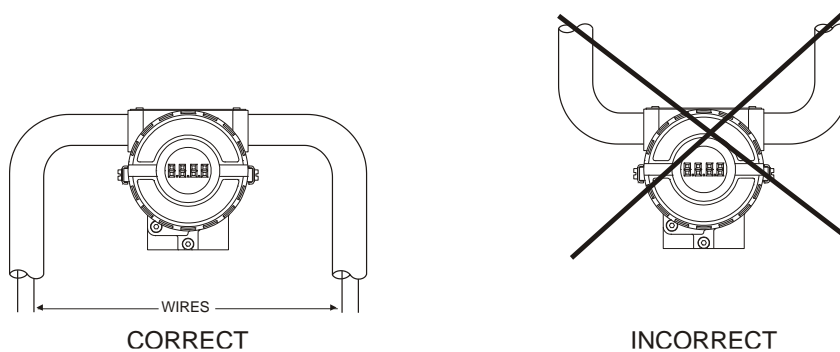

Figure 1.4 - Conduit Installation Diagram

Sensor Wiring

The **TT303** accepts up to two sensors and may operate in one of three modes:

- Single channel single sensor measurement;
- Dual channel dual sensor measurement;
- Single channel dual sensor differential measurement;
- Single channel dual sensor backup measurement;

NOTE

Avoid routing sensor wiring close to power cables or switching equipment.

In accordance with connection and sensor types, the terminal blocks shall be wired as shown on the figure 1.5.

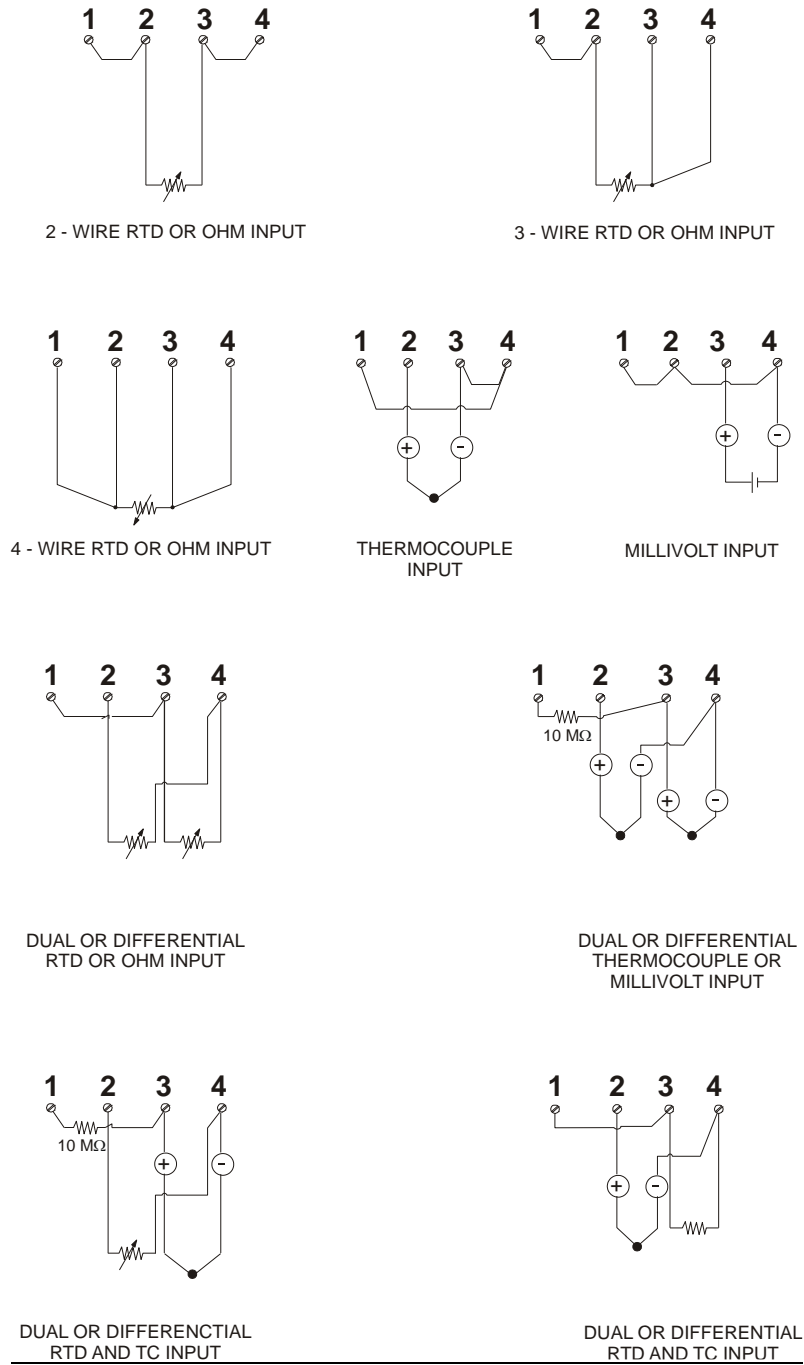

Figure 1.5 - Sensor Wiring

Topology and Network Configuration

Bus topology (see Figures 1.6 and 1.7) are supported. Both types have a trunk cable with two terminations. The devices are connected to the trunk via spurs. The spurs may be integrated in the device giving zero spur length. A spur may connect more than one device, depending on the length. Active couplers may be used to extend spur length.

Active repeaters may be used to extend the trunk length.

The total cable length, including spurs, between any two devices in the Fieldbus should not exceed 1900 m.

The connection of couplers should be kept less than 15 per 250 m. In following figures the DP/PA link depends on the application needs.

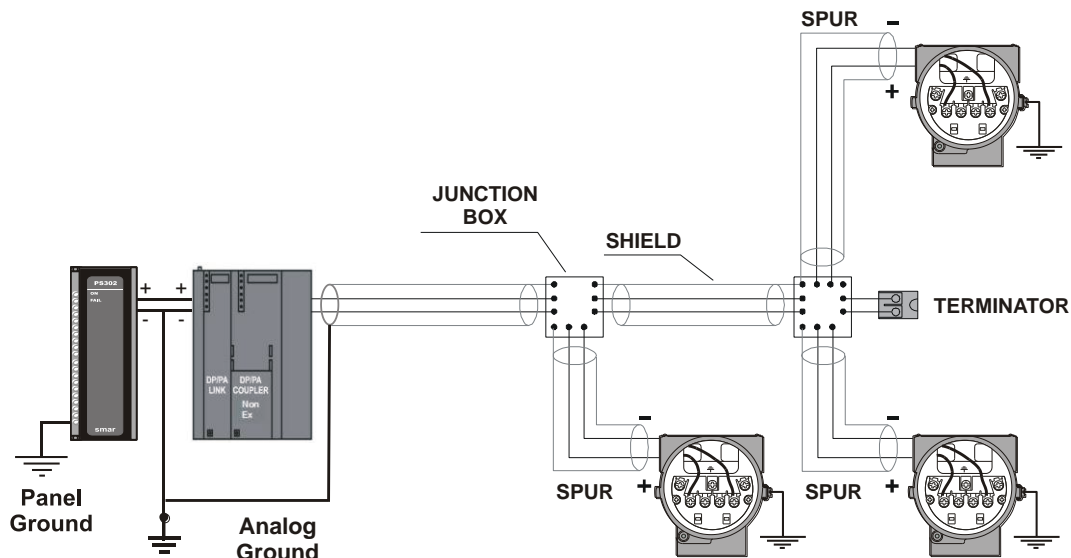

Figure 1.6 - Bus Topology

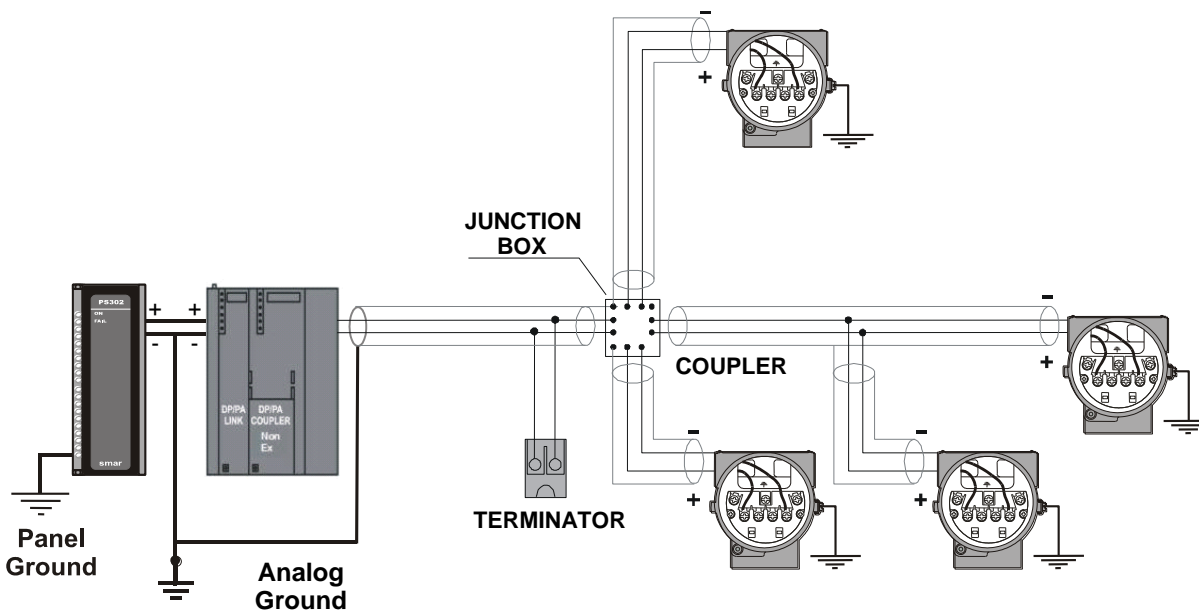

Figure 1.7 - Tree Topology

Intrinsic Safety Barrier

When the Fieldbus is in an area requiring intrinsic safety, a barrier must be inserted on the trunk between the power supply and the DP/PA coupler, when it is Non-Ex type.

Use of **DF47** is recommended.

Jumper Configuration

In order to work properly, the jumpers J1 and W1 located in the **TT303** main board must be correctly configured (See Table 1.1).

J1	This jumper enables the simulation mode parameter in the AI block.
W1	This jumper enables the local adjustment programming tree.

Table 1.1 - Description of the Jumpers

Power Supply

The **TT303** receives power from the bus via the signal wiring. The power supply may come from a separate unit or from another device such as a controller or DCS.

The voltage should be between 9 to 32 Vdc for non-intrinsic safe applications.

A special requirement applies to the power supply used in an intrinsically safe bus and depends on the type of barrier used.

Use of **PS302** is recommended as power supply.

Installation in Hazardous Areas

WARNING

Explosions could result in death or serious injury, besides financial damage. Installation of this transmitter in explosive areas must be carried out in accordance with the local standards and the protection type adopted. Before continuing the installation make sure the certificate parameters are in accordance with the classified area where the equipment will be installed.

The instrument modification or parts replacement supplied by other than authorized representative of Smar is prohibited and will void the certification.

The transmitters are marked with options of the protection type. The certification is valid only when the protection type is indicated by the user. Once a particular type of protection is selected, any other type of protection can not be used.

Explosion/Flame Proof

WARNING

Only use Explosion Proof/Flameproof certified Plugs, Adapters and Cable glands.

In Explosion-Proof installations the cable entries must be connected or closed using metal cable gland and metal blanking plug, both with at least IP66 and Ex-d certification.

The standard plugs provided by Smar are certified according to CEPEL certificate. If the plug needs to be replaced, a certified plug must be used.

The electrical connection with NPT thread must use waterproofing sealant. A non-hardening silicone sealant is recommended.

For NEMKO ATEX certificate please to follow the installation guidelines in hazardous locations below: Group II Category 2G, Ex d, Group IIC, Temperature Class T6, EPL Gb U = 28VDC

Ambient Temperature: -20 to 60°C for T6

Environmental Protection: IP66/687 or IP66W/687W

The electrical connection available are ½ - 14NPT and M20x1,5.

Cable entries must be connected or closed using metal cable gland and metal blanking plug, both with at least IP66 and Ex-d certification or any appropriate ATEX approved metal cable gland and metal blanking plug. Do not remove the transmitter covers when power is ON.

Intrinsically Safe

WARNING

In hazardous zones with intrinsically safe or non-incendive requirements, the circuit entity parameters and applicable installation procedures must be observed.

To protect the application the transmitter **must be connected to a barrier**. Match the parameters between barrier and the equipment (Consider the cable parameters). Associated apparatus ground bus shall be insulated from panels and mounting enclosures. Shield is optional. If used, be sure to insulate the end not grounded. Cable capacitance and inductance plus C_i and L_i must be smaller than C_o and L_o of the associated Apparatus.

It is not recommended to remove the transmitter cover when the power is ON.

Section 2

OPERATION

The **TT303** accepts signals from mV generators such as thermocouples or resistive sensors such as RTDs. The criterion is that the signal is within the range of the input. For mV, the range is -50 to 500 mV and for resistance, 0-2000 Ohm.

Functional Description - Hardware

The function of each block is described below.

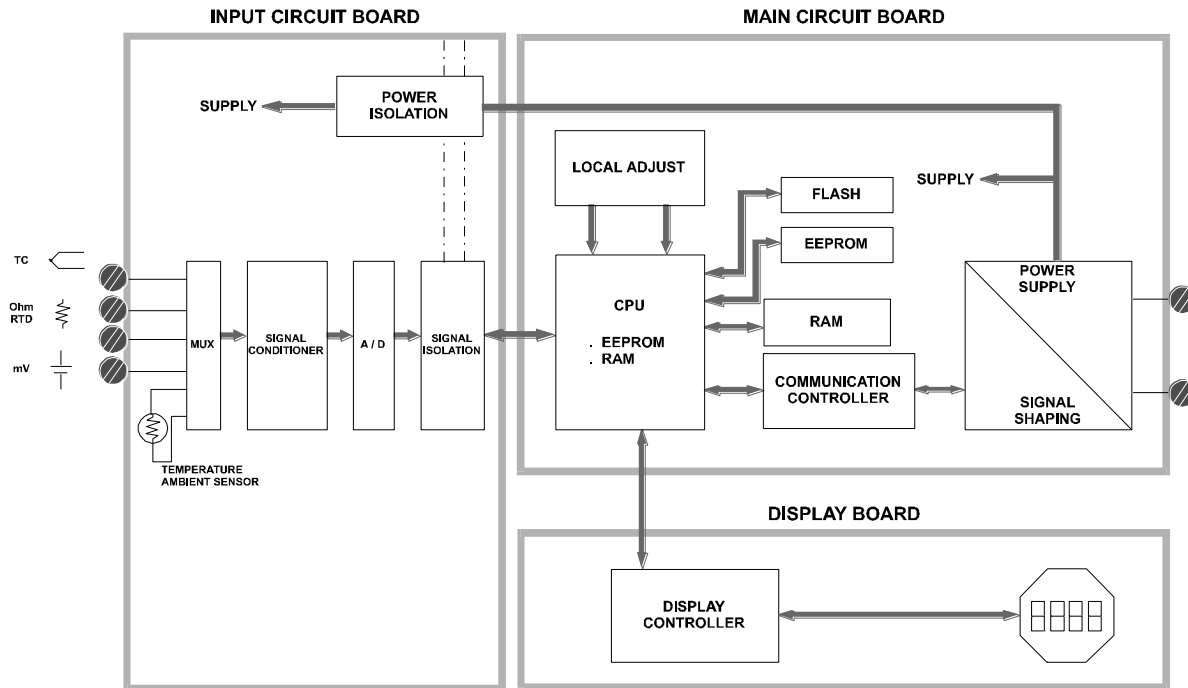

Figure 2.1 - TT303 Block Diagram

MUX Multiplexer

The MUX multiplexes the sensor terminals to the signal conditioning section ensuring that the voltages are measured between the correct terminals.

Signal Conditioner

Its function is to apply the correct gain to the input signals to make them suit the A/D - converter.

A/D Converter

The A/D converts the input signal to a digital format for the CPU.

Signal Isolation

Its function is to isolate the control and data signal between the input and the CPU.

(CPU) Central Processing Unit, RAM, PROM and EEPROM

The CPU is the intelligent portion of the transmitter, being responsible for the management and operation of measurement, block execution, self-diagnostics and communication. The program is stored in a PROM. For temporary storage of data there is a RAM. The data in the RAM is lost if the power is switched off. However there is a nonvolatile EEPROM where data that must be retained is stored. Examples, of such data are trim, calibration, block configuration and identification data.

Communication Controller

It monitors line activity, modulates and demodulates communication signals and inserts and deletes start and end delimiters.

Power Supply

Takes power of the loop-line to power the transmitter circuitry.

Power Isolation

Just like the signals to and from the input section, the power to the input section must be isolated. Isolation is achieved by converting the DC supply into a high frequency AC supply and galvanically separating it using a transformer.

Display Controller

Receives data from the CPU informing which segments of the Liquid Crystal Display, should be turned on.

Local Adjustment

There are two switches that are magnetically activated. They can be activated by the magnetic tool without mechanical or electrical contact.

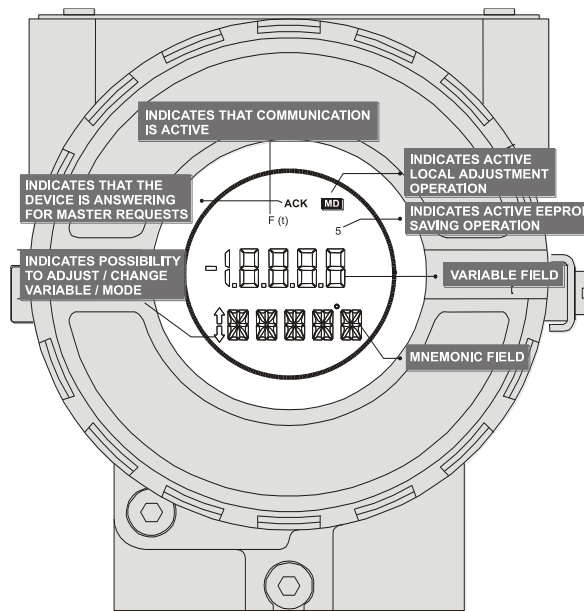

Figure 2.2 - LCD Indicator

Temperature Sensors

The TT303, as previously explained, accepts several types of sensors. The TT303 is specially designed for temperature measurement using thermocouples or Resistive Temperature Detectors (RTDs).

Some basic concepts about these sensors are presented below.

Thermocouples

Thermocouples are constructed with two wires made from different metals or alloys joined at one end, called measuring junction or "hot junction". The measuring junction should be placed at the point of measurement. The other end of the thermocouple is open and connected to the temperature transmitter. This point is called reference junction or cold junction.

For most applications, the Seebeck effect is sufficient to explain thermocouple behavior as following:

How the Thermocouple Works (Seebeck Effect)

When there is a temperature difference along a metal wire, a small electric potential, unique to every alloy, will occur. This phenomenon is called Seebeck effect. When two wires of dissimilar metals are joined at one end, and left open at the other, a temperature difference between the two ends will result in a voltage since the potentials generated by the dissimilar materials are different and do not cancel each other out. Now, two important things must be noted. First: the voltage generated by the thermocouple is proportional to the difference between the measuring-junction and the cold junction temperatures.

Therefore the temperature at the reference junction must be added to the temperature derived from the thermocouple output, in order to find the temperature measured. This is called cold junction compensation, and is done automatically by the **TT303**, which has a temperature sensor at the sensor terminals for this purpose. Secondly, if the thermocouple wires are not used, all the way to the terminals of the transmitter (e.g., copper wire is used from sensor-head or marshaling box) will form new junctions with additional Seebeck effects. It will be created and ruin the measurement in most cases, since the cold-junction compensation will be done at the wrong point.

NOTE

Use thermocouple wires or appropriate extension wires all the way from sensor to transmitter.

The relation between the measuring junction temperature and the generated millivoltage is tabulated in thermocouple calibration tables for standardized thermocouple types, the reference temperature being 0°C.

Standardized thermocouples that are commercially used, whose tables are stored in the memory of the **TT303**, are the following:

- NBS (B, E, J, K, N, R, S & T)
- DIN (L & U)

Resistive Temperature Detectors (RTDs)

Resistance Temperature Detectors, most commonly known as RTD's, are based on the principle that the resistance of metal increases as its temperature increases.

Standardized RTDs, whose tables are stored in the memory of the **TT303**, are the following:

- JIS [1604-81] (Pt50 & Pt100)
- IEC, DIN, JIS [1604-89] (Pt50, Pt100 & Pt500)
- GE (Cu10)
- DIN (Ni120)

For correct measurement of RTD temperature, it is necessary to eliminate the effect of the resistance of the wires connecting the sensor to the measuring circuit. In some industrial applications, these wires may be hundreds of meters long. This is particularly important at locations where the ambient temperature changes constantly.

The **TT303** permits a 2-wire connection that may cause measuring errors, depending on the length of connection wires and on the temperature to which they are exposed. (see Figure 2.3).

In a 2-wire connection, the voltage V_2 is proportional to the RTD resistance plus the resistance of the wires.

$$V_2 = [RTD + 2 \times R] \times I$$

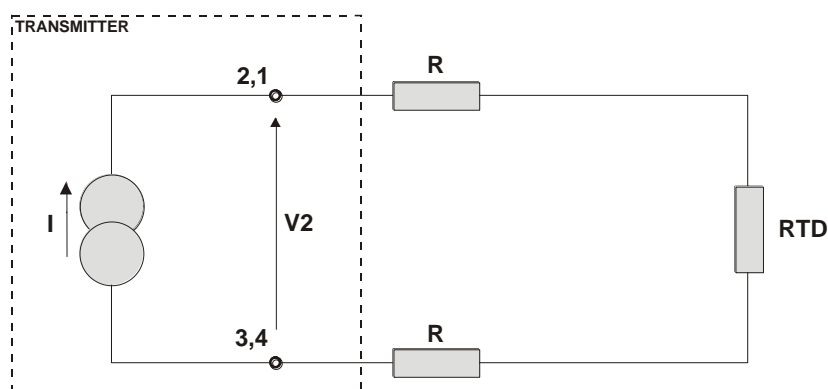

Figure 2.3 - Two-Wire Connection

In order to avoid the resistance effect of the connection wires, it is recommended to use a 3-wire connection (see Figure 2.4) or a 4-wire connection (see Figure 2.5).

In a 3-wire connection, terminal 3 is a high impedance input. Thus, no current flows through that wire and no voltage drop is caused. The voltage $V_2 - V_1$ is independent of the wire resistances since they will be cancelled, and is directly proportional to the RTD resistance alone.

$$V_2 - V_1 = [RTD + R] \times I - R \times I = RTD \times I$$

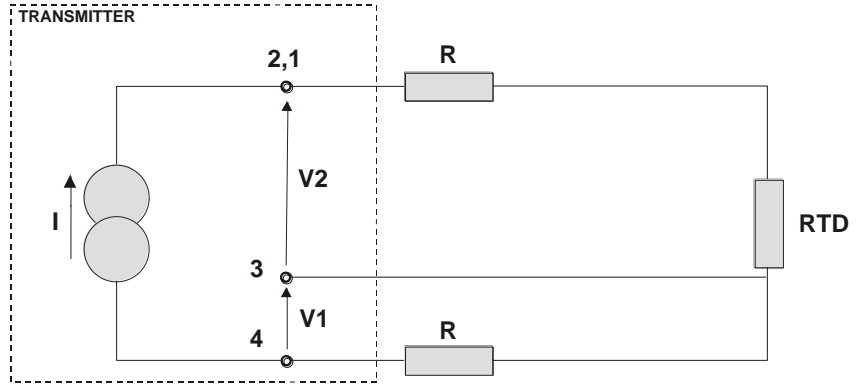

Figure 2.4 - Three - Wire Connection

In a 4-wire connection, terminals 2 and 3 are high impedance inputs. Thus, no current flows through those wires and no voltage drop is caused. The resistance of the other two wires is not of interest, since there is no measurement registered on them. Hence the voltage V_2 is directly proportional to the RTD resistance.

$$(V_2 = RTD \times I)$$

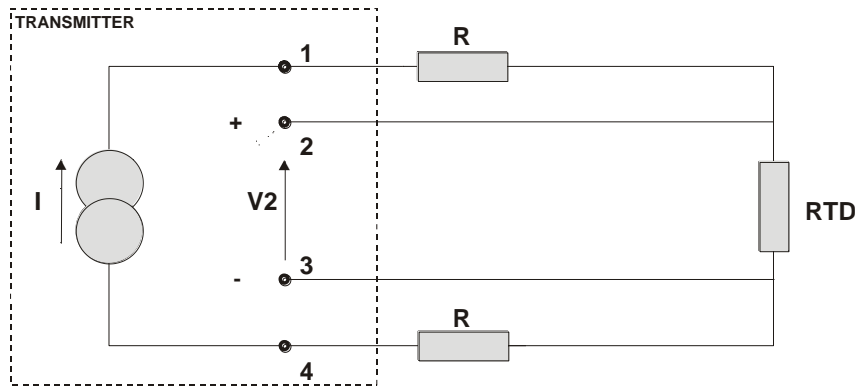

Figure 2.5 - Four - Wire Connection

A differential or dual channel connection is similar to the two-wire connection and gives the same problem (See Figure 2.6). The resistance of the wires will be measured and do not cancel each other out in a temperature measurement, since linearization will affect them differently.

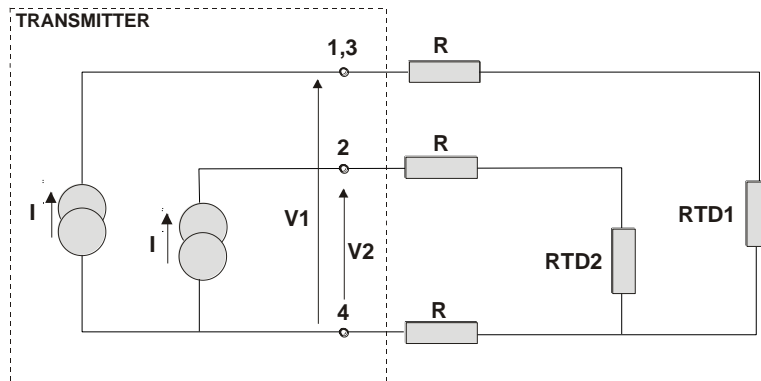

Figure 2.6 - Differential or Dual Connection

The Display

The digital indicator is able to display one or two variables which are user selectable. When two variables are chosen, the display will alternate between the two with an interval of 3 seconds.

The different fields and status indicators are explained in Figure 2.7.

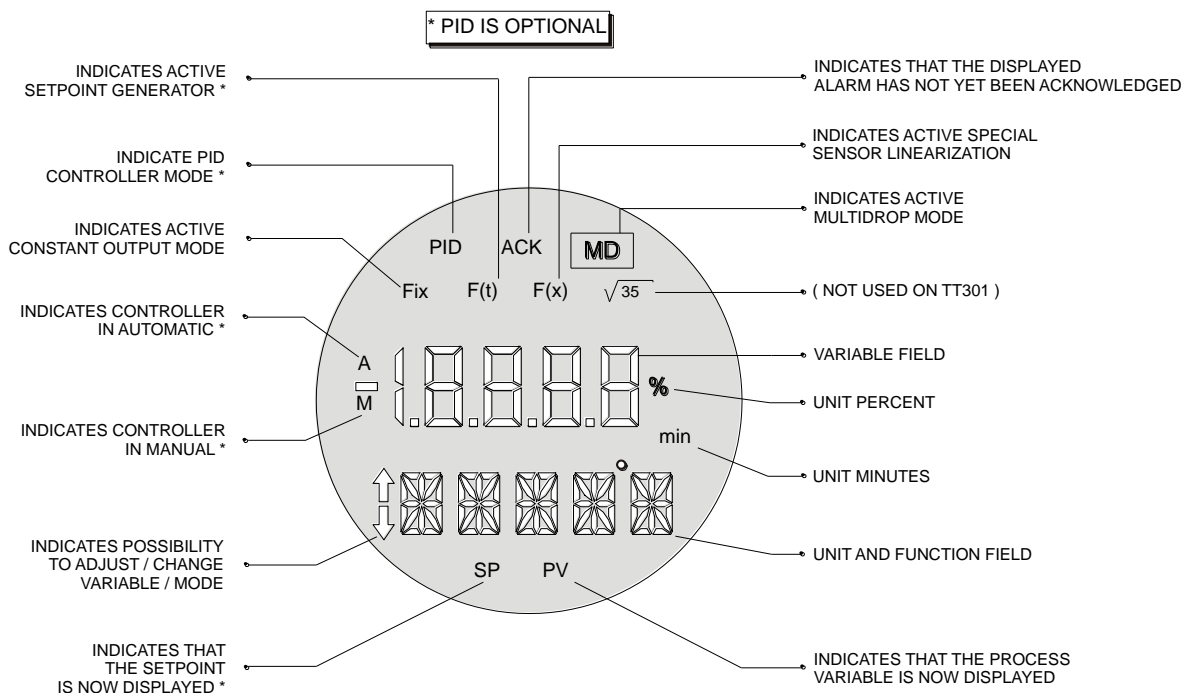

Figure 2.7 – Typical Monitoring Mode Display

Monitoring

During normal operation, the **TT303** is in the monitoring mode. In this mode, indication alternates between the primary and secondary variable as configured in DISPLAY. See Figure 2.8.

The display indicates engineering units, values and parameters simultaneously with most status indicators. The monitoring mode is interrupted in two situations:

- ✓ User performs complete local adjustment.
- ✓ An alarm is activated.

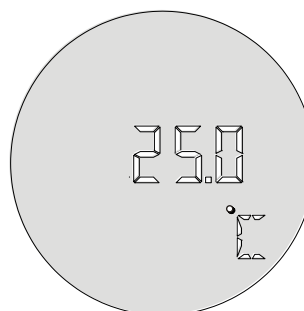

Figure 2.7 – Display

Alarm

The two alarms are software alarms and have no contacts available on the transmitter. The alarms are acknowledged by using the Local Adjustment or the Configurator, which can view and configure alarms as well - see further Section III. During an alarm, the display will indicate which alarm has been activated and if it has been acknowledged or not.

The transmitter display also indicates the alarms status as shown in Figure 2.9.

AL H means High Alarm, AL L means Low Alarm and ALO indicates Burnout failure. The ACK indicates that the alarm has not yet been acknowledged.

When the alarm condition disappears, the "ACK" is switched off and the display returns to monitoring mode.

For further information on alarm configuration, see Section III - Programming Using Terminal.

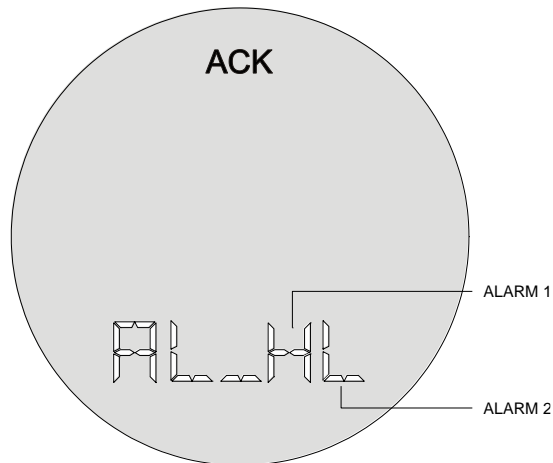

Figure 2.9 – Typical Alarm Condition Display

CONFIGURATION

This section describes the characteristics of the blocks in the **TT303**. They follow the Profibus PA specifications, but in terms of transducer blocks, the input transducer block and display, they have some special features on top of this.

The **TT303** contains two input transducer blocks, one resource block, one display transducer block.

For explanation and details of function blocks, see the “Function Blocks Instruction Manual”.

The 303 Smar family is integrated in **Profibus View**, from Smar and in the **Simatic PDM**, from Siemens. It is possible to integrate any 303 Smar device into any configuration tool for Profibus PA devices. It is necessary to provide a Device Description or Drive according to the configuration tool. In this manual is taken several examples using **Profibus View** or **Simatic PDM**.

In order to assure correct values in the offline configuration, first run “Download to PG/PC” option to assure valid values. After, run the Menu Device option to configure the required parameters using the related menus.

NOTE

In offline configuration, it is not advisable to use the “Download to Device” option. This function can misconfigure the equipment.

Transducer Block

Transducer block insulates function blocks from the specific I/O hardware, such as sensors, actuators. Transducer block controls access to I/O through manufacturer specific implementation. This permits the transducer block to execute as frequently as necessary to obtain good data from sensors without burdening the function blocks that uses the data. It also insulates the function block from the manufacturer specific characteristics of certain hardware.

By accessing the hardware, the transducer block can get data from I/O or passing control data to it. The connection between Transducer block and Function block is called channel. These blocks can exchange data from its interface.

Normally, transducer blocks perform functions, such as linearization, characterization, temperature compensation, control and exchange data to hardware.

How to Configure a Transducer Block

The transducer block has an algorithm, a set of contained parameters, it means, you are not able to link these parameters to other blocks and publish the link via communication, and a channel connecting it to a function block.

The algorithm describes the behavior of the transducer as a data transfer function between the I/O hardware and other function block. The set of contained parameters defines the user interface to the transducer block. They can be divided into Standard and Manufacturer Specific.

The standard parameters will be present for such class of device, as pressure, temperature, actuator, etc., whatever is the manufacturer. Oppositely, the manufacturers specific ones are defined only for its manufacturer. As common manufacturer specific parameters, we have calibration settings, material information, linearization curve, etc.

When you perform a standard routine such as calibration, you are conducted step by step by a method. The method is generally defined as guideline to help the user to make common tasks. The **Configuration Tool** identifies each method associated to the parameters and enables the interface to it.

Functional Diagram of the Temperature Transducer Block

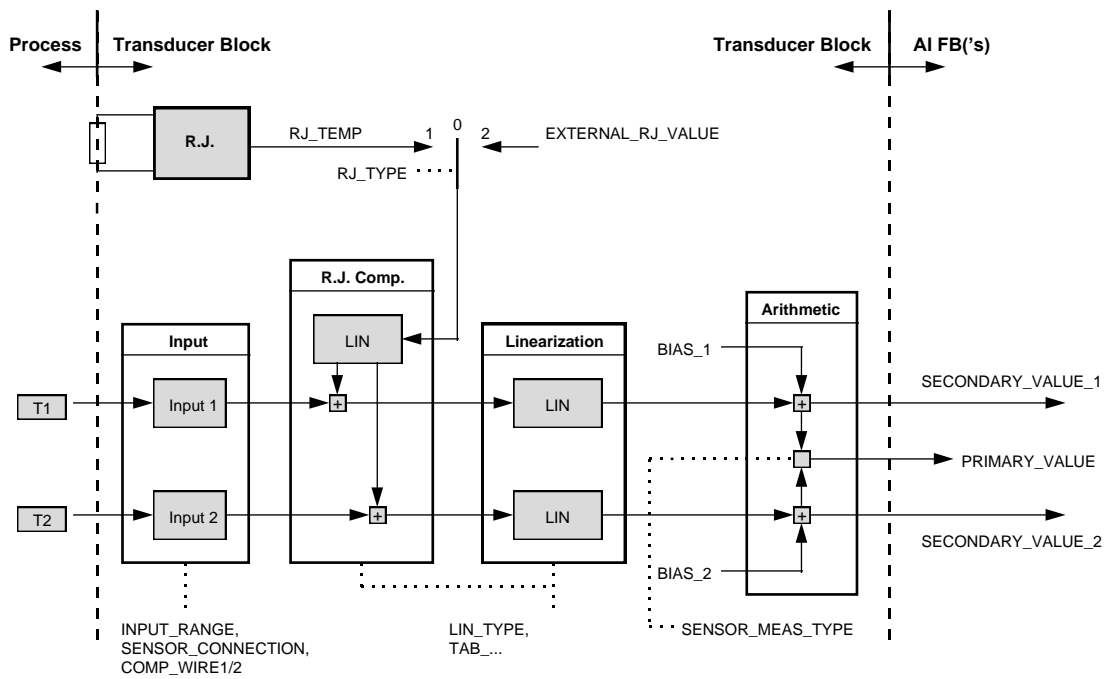

Figure 3.1 – Functional Diagram of the Temperature Block

Temperature Transducer Block General Parameter Description

Temperature Transducer Block General Parameter Description formatted: font: Not Bold, English (U.S.)

PARAMETER	DESCRIPTION
BIAS_1	Bias that can be algebraically added to process value of channel 1. The unit of BIAS_1 is the PRIMARY_VALUE_UNIT.
BIAS_2	Bias that can be algebraically added to process value of channel 2. The unit of BIAS_2 is the PRIMARY_VALUE_UNIT.
INPUT_FAULT_GEN	Input malfunction: Diagnosis object for errors that concerns all values 0 = device OK Bit: 0 = Rj error 1 = Hardware error 2 – 4 = reserved 5 – 7 = manufacturer specific Byte: 0x00: status ok; 0x80: hardware failure
INPUT_FAULT_1	Input malfunction: Diagnosis object for errors that concern SV_1 0 = Input OK Bit: 0 = underrange 1 = overrange 2 = lead breakage 3 = short circuit 4 – 5 = reserved 6 – 7 = manufacturer specific Byte: 0x00: input ok; 0x80: sensor failure

PARAMETER	DESCRIPTION
INPUT_FAULT_2	Input malfunction: Diagnosis object for errors that concern SV_2 0 = Input OK Bit and byte definition see INPUT_FAULT_1
INPUT_RANGE	Electrical input range and mode. The ranges are manufacturer specific but range n is smaller than range n+1 if more than one range is supported for one input mode (e.g. range1=0...400Ω, range2=0...4kΩ). INPUT_RANGE is equal for channel 1 and 2. Defined codes (other codes are reserved): 0 = mV range 1 => mV22 1 = mV range 2 => mV100 2 = mV range 3=> mV500 : 9 = mV range 10 128 = Ω range 1 => Ohm 100 129 = Ω range 2 => Ohm 400 130 = Ω range 3 => Ohm 2000 : 137 = Ω range 10 192 = mA range 1 193 = mA range 2 : 201 = mA range 10 240 = manufacturer specific : 249 = manufacturer specific 250 = not used 251 = none 252 = unknown 253 = special Remark: When using codes 240..249 (manufacturer specific) interchangeability is not possible.
LIN_TYPE	Select the type of sensor (Code) for Thermocouples, Rtd, Pyrometers or linear. 101 = RTD Pt50 a=0.003850 (IEC 751, DIN 43760, JIS C1604-97, BS1904) 102 = RTD Pt100 a=0.003850 (IEC 751, DIN 43760, JIS C1604-97, BS1904) 104 = RTD Pt500 a=0.003850 (IEC 751, DIN 43760, JIS C1604-97, BS1904) 107 = RTD Pt50 a=0.003916 (JIS C1604-81) 108 = RTD Pt100 a=0.003916 (JIS C1604-81) 120 = RTD Ni120 a=0.006720 (Edison curve #7) 121 = TC Type E, Ni10Cr-Cu45Ni (IEC584, NIST MN 175, DIN 43710, BS 4937, ANSI MC96.1, JIS C1602, NF C42-321) 128 = TC Type B, Pt30Rh-Pt6Rh (IEC 584, NIST MN 175, DIN 43710, BS 4937, ANSI MC96.1, JIS C1602, NF C42-321) 133 = TC Type J, Fe-Cu45Ni (IEC 584, NIST MN 175, DIN 43710, BS 4937, ANSI MC96.1, JIS C1602, NF C42-321) 134 = TC Type K, Ni10Cr-Ni5 (IEC 584, NIST MN 175, DIN 43710, BS 4937, ANSI MC96.1, JIS C1602, NF C42-321) 135 = TC Type N, Ni14CrSi-NiSi (IEC 584, NIST MN 175, DIN 43710, BS 4937, ANSI MC96.1, JIS C1602, NF C42-321) 136 = TC Type R, Pt13Rh-Pt (IEC 584, NIST MN 175, DIN 43710, BS 4937, ANSI MC96.1, JIS C1602, NF C42-321) 137 = TC Type S, Pt10Rh-Pt (IEC 584, NIST MN 175, DIN 43710, BS 4937, ANSI MC96.1, JIS C1602, NF C42-321) 138 = TC Type T, Cu-Cu45Ni (IEC 584, NIST MN 175, DIN 43710, BS 4937, ANSI MC96.1, JIS C1602, NF C42-321) 139 = TC Type L, Fe-CuNi (DIN 43710) 140 = TC Type U, Cu-CuNi (DIN 43710) 145 to 239 reserved Manufacturer specific: 240 Cu10 GE, Edison #15 241 Ohm 100 242 Ohm 400 243 Ohm 2000 244 mV22 245 mV100 246 mV500 : 249 Manufacturer specific 250 Not used 251 None 252 Unknown 253 Special

PARAMETER	DESCRIPTION
LOWER_SENSOR_LIMIT	Physical lower limit function of sensor (e.g. Pt 100 = -200°C) and input range. In the case of multichannel measurements (e.g. differential measurement) the meaning of LOWER_SENSOR_LIMIT is the limit of one channel not the calculated limit of both channels. The unit of LOWER_SENSOR_LIMIT is the PRIMARY_VALUE_UNIT.
PRIMARY_VALUE	Process value, function of SECONDARY_VALUE_1/2. The unit of PRIMARY_VALUE is the PRIMARY_VALUE_UNIT.
PRIMARY_VALUE_UNIT	Show the unit code of the PRIMARY_VALUE and other values. The unit is select using PRIMARY_VALUE_RANGE parameter. Set of unit codes: 1000: K (Kelvin) 1001: °C (degree Celsius) 1002: °F (degree Fahrenheit) 1003: Rk (Rankine) 1281: Ω (Ohm) 1243: mV (milivolt)
SECONDARY_VALUE_1 (SV_1)	Process value connected to the channel 1 corrected by BIAS_1. The unit of SECONDARY_VALUE_1 is the PRIMARY_VALUE_UNIT.
SECONDARY_VALUE_2 (SV_2)	Process value connected to the channel 2 corrected by BIAS_2. The unit of SECONDARY_VALUE_2 is the PRIMARY_VALUE_UNIT.
SENSOR_MEAS_TYPE	Mathematical function to calculate PRIMARY_VALUE (PV). Defined codes: 128: PV = SV_1 - SV_2 Difference manufacturer specific: 220: = Backup 230: = Process Temperature
UPPER_SENSOR_LIMIT	Physical upper limit function of sensor (e.g. Pt 100 = 850°C) and input range. In the case of multichannel measurements (e.g. differential measurement) the meaning of UPPER_SENSOR_LIMIT is the limit of one channel not the calculated limit of both channels. The unit of UPPER_SENSOR_LIMIT is the PRIMARY_VALUE_UNIT.
COMP_WIRE1	Value in OHM to compensate line resistance when the thermoresistance 1 is connected with 2 or 3 wires.
COMP_WIRE2	Value in OHM to compensate line resistance when the thermoresistance 2 is connected with 2 or 3 wires.
SENSOR_CONNECTION	Connection to the sensor, select for 2, 3 and 4 wires connection. Defined codes: 0 = 2 wires 1 = 3 wires 2 = 4 wires 3 = 2 dual wires
PRIMARY_VALUE_RANGE	The high and low range limits values, the engineering units and the number of digits to the right of the decimal to be used to display the primary value.
CAL_POINT_HI	This parameter contains the highest calibrated value. For calibration of the high limit point you give the high measurement value (temperature) to the sensor and transfer this point as HIGH to the transmitter. Unit derives from CAL_UNIT.
CAL_POINT_LO	This parameter contains the lowest calibrated value. For calibration of the low limit point you give the low measurement value (temperature) to the sensor and transfer this point as LOW to the transmitter. Unit derives from CAL_UNIT.
CAL_MIN_SPAN	This parameter contains the minimum calibration span value allowed. This minimum span information is necessary to ensure that when calibration is done, the two calibrated points (high and low) are not too close together. Unit derives from CAL_UNIT.
CAL_UNIT	The unit for calibration process: {1000, "Kelvin"}, {1001, "Celsius"}, {1002, "Fahrenheit"}, {1003, "Rankie"}, {1243, "mV"}, {1281, "Ohm"}
SENSOR_RANGE	The high and low range limits values, the engineering units and the number of digits to the right of the decimal to be used to describe the operating limits for the sensor.
SENSOR_SN	The sensor serial number.
SECONDARY_VALUE	The secondary value related to the sensor.
SECONDARY_UNIT	The engineering units to be used with the secondary value related to the sensor.
MODULE_SN	Indicates the number of the module.
SECONDARY_VALUE_ACTION	Allows to enable and to disable the cold junction. {0, "Disable"}, {1, "Enable"}
TWO_WIRES_COMPENSATION	Allows the compensation of line resistance for double RTD or Ohm sensors. {0, "Disable"}, {1, "Enable"}
SENSOR_TRANSDUCER_NUMBER	Selects the Transducer 1 or 2.
FACTORY_DIGITAL_INPUTS	Reads the digital inputs.
FACTORY_GAIN_REFERENCE	Calibration point for Ohm and mV sensors.
FACTORY_TERMINAL_REFERENCE	Calibration point for the Borne Resistance.
BACKUP_RESTORE	This parameter allows to save and to restore data according to factory and user calibration procedures. It has the following options:

PARAMETER	DESCRIPTION
	1, "Factory Cal Restore", 2, "Last Cal Restore", 3, "Default Data Restore", 11, "Factory Cal Backup", 12, "Last Cal Backup", 14, "Shut-Down Data Backup", 0, "None".
XD_ERROR	Indicates the condition of calibration process according to: {16, "Default value set"}, {22, "Applied process out of range"}, {26, "Invalid configuration for request"}, {27, "Excess correction"}, {28, "Calibration failed"}
EEPROM_FLAG	This parameter is used to indicate EEPROM saving process.
MAIN_BOARD_SN	This is the main board serial number.
ORDERING_CODE	Indicates information about the sensor and control from production factory.

Table 3.1 - Parameter Description

Temperature Transducer Block General Parameter Attributes

Temperature Transducer Block General Parameter Attributes

Relative Index	Parameter Name	Object type	Data type	Store	Size	Access	Param. Usage/ Type of Transport	Default Value	Download Order	Mandatory Optional (Class)	View	
... Standard Parameter see General Requirements												
General Parameter for Temperature Transducer Block												
8	PRIMARY_VALUE	simple	DS-33	D	5	r	C/a			M	1	
9	PRIMARY_VALUE_UNIT	simple	Unsigned 16	S	2	r,w	C/a		2	M		
10	SECONDARY_VALUE_1	simple	DS-33	D	5	r	C/a			M		
11	SECONDARY_VALUE_2	simple	DS-33	D	5	r	C/a			O		
12	SENSOR_MEAS_TYPE	simple	unsigned 8	S	1	r,w	C/a		3	M		
13	INPUT_RANGE	simple	unsigned 8	S	1	r,w	C/a		4	M		
14	LIN_TYPE	See General Requirements.								1	M	
19	BIAS_1	simple	Float	S	4	r,w	C/a	0.0	5	M		
20	BIAS_2	simple	Float	S	4	r,w	C/a	0.0		O		
21	UPPER_SENSOR_LIMIT	simple	Float	N	4	r	C/a			M		
22	LOWER_SENSOR_LIMIT	simple	Float	N	4	r	C/a			M		
24	INPUT_FAULT_GEN	simple	unsigned 8	D	1	r	C/a			M	1	
25	INPUT_FAULT_1	simple	unsigned 8	D	1	r	C/a			M	1	
26	INPUT_FAULT_2	simple	unsigned 8	D	1	r	C/a			O		
27-35	Not used											
36	SENSOR_CONNECTION	simple	unsigned 8	S	1	r,w	C/a		7	M		
37	COMP_WIRE1	simple	Float	S	4	r,w	C/a	0.0	8	M		
38	COMP_WIRE2	simple	Float	S	4	r,w	C/a	0.0		O		
39 – 61	Not used											
62	PRIMARY_VALUE_RANGE	record	DS-36	S	11	r,w	C/a					
63	CAL_POINT_HI	simple	Float	S	4	r,w	C/a	850.0				
64	CAL_POINT_LO	simple	Float	S	4	r,w	C/a	-200.0				
65	CAL_MIN_SPAN	simple	Float	S	4	r	C/a	10.0				
66	CAL_UNIT	simple	Unsigned 16	S	2	r,w	C/a	1001				
67	SENSOR_RANGE	record	DS-36	N	11	r	C/a					
68	SENSOR_SN	simple	Unsigned 32	S	4	r,w	C/a					
69	SECONDARY_VALUE	simple	DS-33	D	5	r	C/a					
70	SECONDARY_VALUE_UNIT	simple	Unsigned 16	S	2	r,w	C/a	1001				

Relative Index	Parameter Name	Object type	Data type	Store	Size	Access	Param. Usage/ Type of Transport	Default Value	Download Order	Mandatory Optional (Class)	View
71	MODULE_SN	simple	Unsigned 32	S	4	r,w	C/a				
72	SECONDARY_VALUE_ACTION	simple	Unsigned 8	S	1	r,w	C/a				
73	TWO_WIRES_COMPENSATION	simple	Unsigned 8	S	1	r,w	C/a				
74	SENSOR_TRANSDUCER_NUMBER	simple	Unsigned 8	S	1	r,w	C/a				
75	FACTORY_DIGITAL_INPUTS	simple	Float	N	4	r,w	C/a				
76	FACTORY_GAIN_REFERENCE	simple	Unsigned 8	S	1	r,w	C/a				
77	FACTORY_BORNE_REFERENCE	simple	Unsigned 8	S	1	r,w	C/a				
78	BACKUP_RESTORE	simple	Unsigned 8	S	1	r,w	C/a				
79	XD_ERROR	simple	Unsigned 8	D	1	r	C/a				
80	MAIN_BOARD_SN	simple	Unsigned 32	S	4	r,w	C/a				
81	EEPROM_FLAG	simple	Unsigned 8	D	1	r	C/a				
82	ORDERING_CODE	simple	Unsigned 8	S	50	r,w	C/a				

Table 3.2 - General Parameter for Temperature Transducer Block

TT303 - Cyclic Configuration

The PROFIBUS-DP and PROFIBUS-PA protocols have mechanisms against communication failures between the slave device and the network master. For example, during initialization, these mechanisms are used to check these possible errors. After powering up the field device (slave), it can cyclically exchange information with the class 1 master, if the parameterization for the slave is correct. This information is obtained using the GSD files (supplied by the device manufacturer, it contains their descriptions). Through the commands below, the master executes all initialization process with the PROFIBUS-PA device:

- Get_Cfg: uploads the slave configuration on the master and checks network configuration;
- Set_Prm: writes to the slave parameters and executes the parameterization network;
- Set_Cfg: configures the slaves according to its outputs and inputs;
- Get_Cfg: another command, where the master checks the slave configuration.

All these services are based on the information obtained from slave gsd files. The GSD file from **TT303** shows details such as, hardware and software revision, device bus timing and information about cyclic data exchange. **TT303** has 1 functional block: AI.

Most PROFIBUS configuration tools use two directories where the different manufacturers' GSD's and BITMAPS files are stored. The GSD's and BITMAPS for Smar devices can be obtained through the website: (<https://www.smar.com>), on the 'download' link.

The following example shows the necessary steps to integrate the **TT303** on a Profibus system. These steps are valid for the entire 303 line of Smar devices:

- Copy the **TT303** gsd file to the research directory of the PROFIBUS configuration tool, usually called GSD;
- Copy the **TT303** bitmap file to the research directory of the PROFIBUS configuration tool usually called BMP;
- After choosing the master, define the baud rate for the network. Do not forget that couplers may work with the following baud rate: 45.45 kbits/s (Siemens model), 93.75 kbits/s (P+F model) and 12 Mbits/s (P+F, SK2 model). The IM157 device link (Siemens model) may work up to 12 Mbits/s;

- Add the **TT303** and specify its physical bus address;
- Choose the cyclic configuration via parameterization using the gsd file that depends on the application, as detailed previously. For every AI (Analog Input) block, the **TT303** provides the process variable to the master in 5 bytes value, being the first four according to float point data type and the fifth byte is the status that brings the measure quality of this information;
- It allows activating the condition of watchdog, which the device goes to a fail safe condition, when a loss of communication is detected with the master.



Configuration softwares like **Profibus View** from Smar or **Simatic PDM** (Process Device Manager) from Siemens can configure many parameters of the Input Transducer block. See the figures 3.2 and 3.3.

The device was created as TT303.

Here, you can see all blocks instantiated.

As you can see the Transducer and Display are treated as special type of Function Blocks, called Transducer Blocks.

Figura 3.2 – Profibus View – Function and Transducers Block

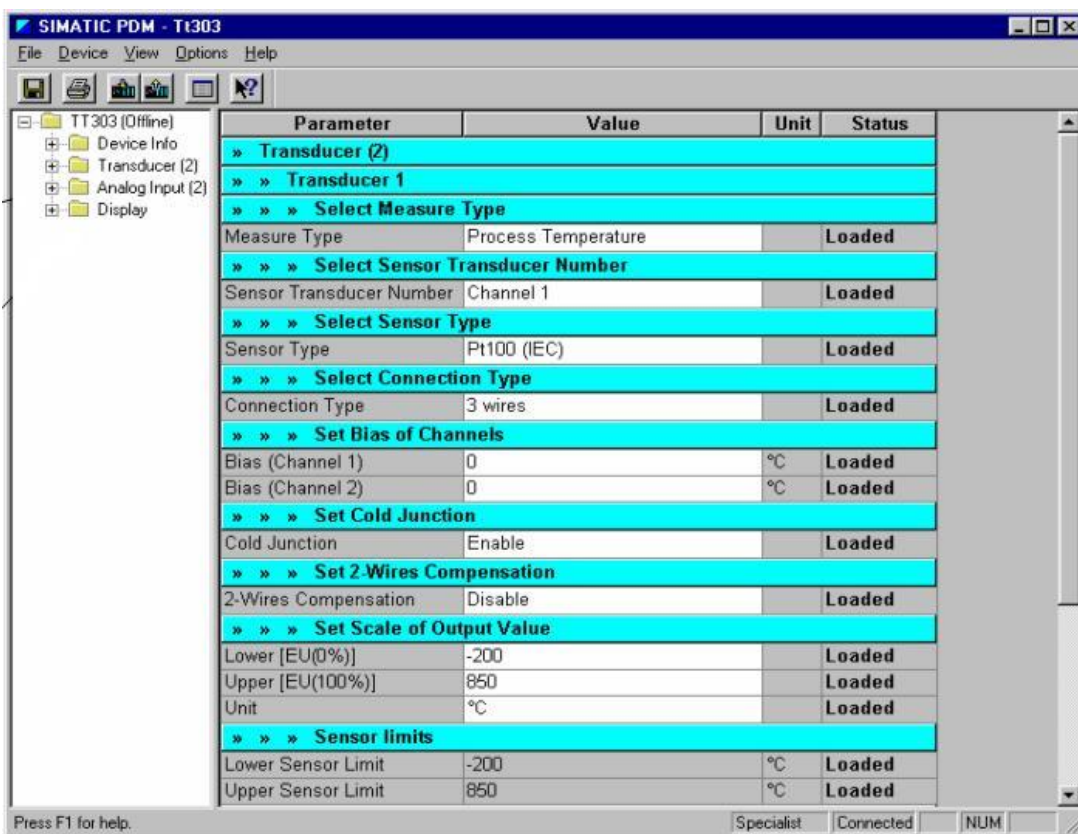

Figure 3.3 – PDM Simatic - Function and Transducers Blocks



Use this menu:

- To change the device address;
- To make the up/download of parameters;
- To configure the Transducer Blocks, Analog Blocks and Display Block;
- To calibrate the transmitter;
- To make the reset by software, to protect the device against writing and to simulate the value from transducer block to analog block;
- To save and restore data calibration.

To make the configuration of Transducer Block, we need to select the Transducer 1 block on the main menu.

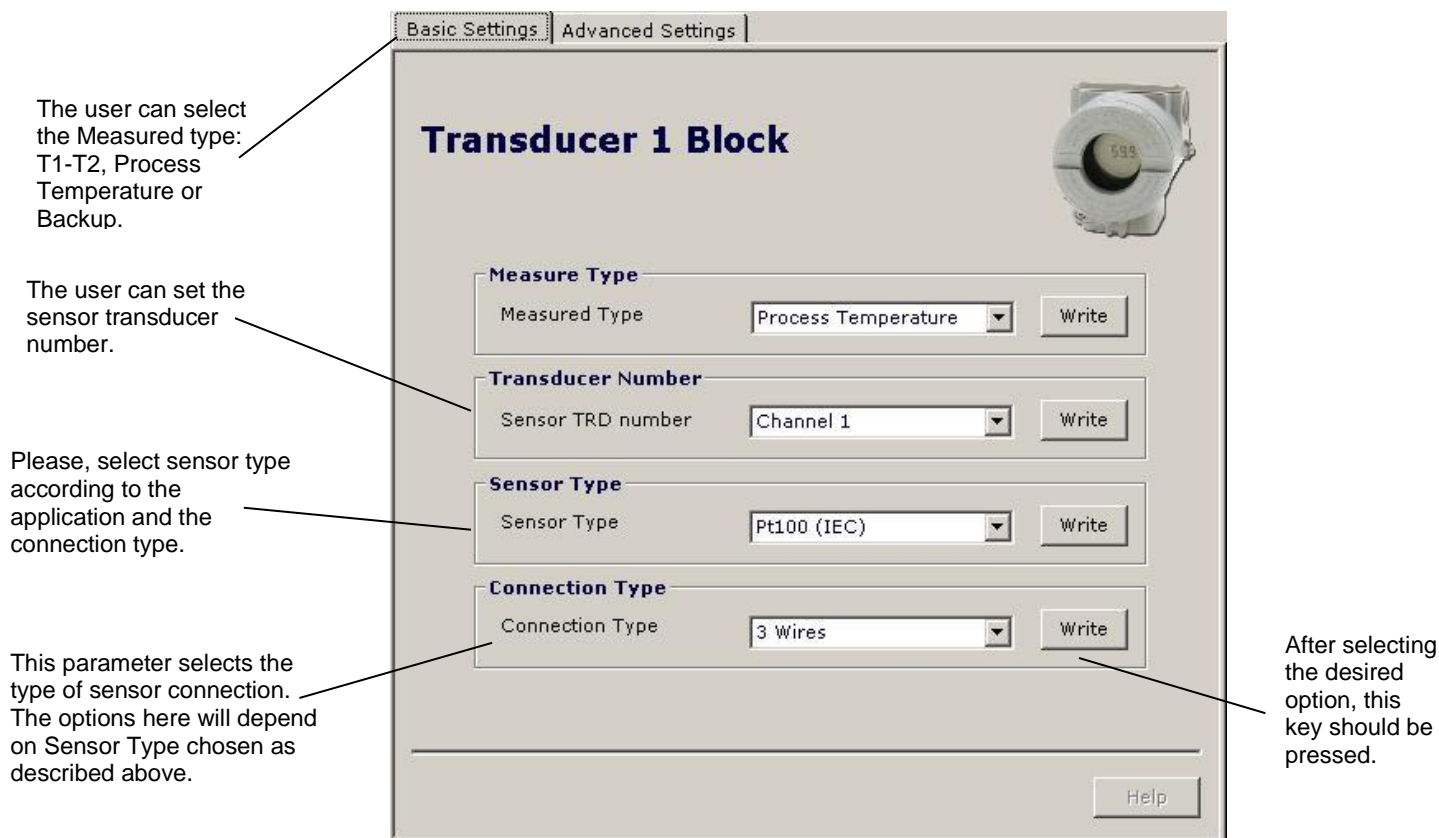

Figure 3.4 - Profibus View - Transducer Basic Settings

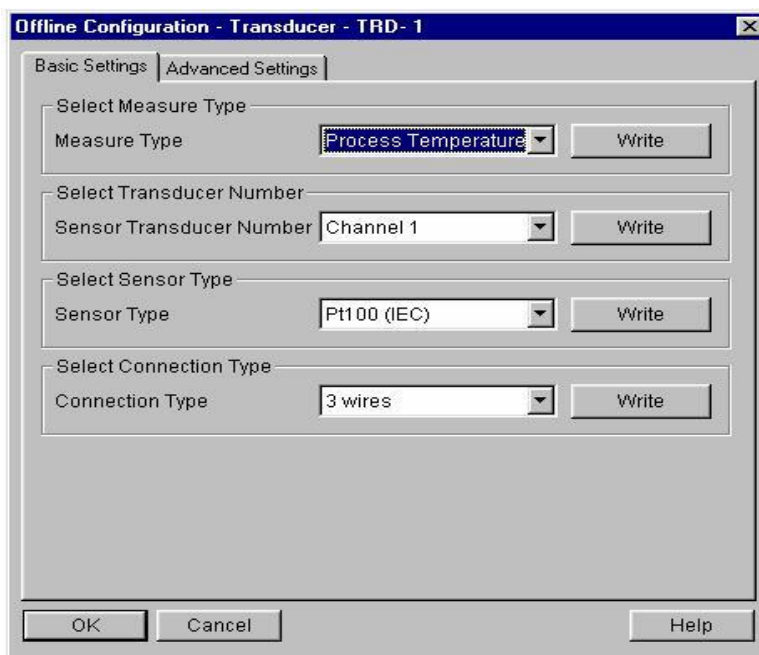

Figure 3.5 – PDM Simatic - Offline Configuration - Transducer Basic Settings

The user can configure the Transducer Block, according to the selected Measure Type (when you have selected "Process Temperature", it means that you will have two sensors, two transducer blocks and two analog input blocks). Please, select the parameters according to your application.

It is possible to configure connection and sensor type by means of parameters SENSOR_TYPE and SENSOR_CONNECTION. The connection and sensor types available are listed in the tables Table 3.6 and Table 3.7.

Using the "Advanced Settings" window, the user can set the scaling and unit for the output value according to the Transducer Block Diagram, bias of channels and set the cold junction and 2-wires compensation according to his application.

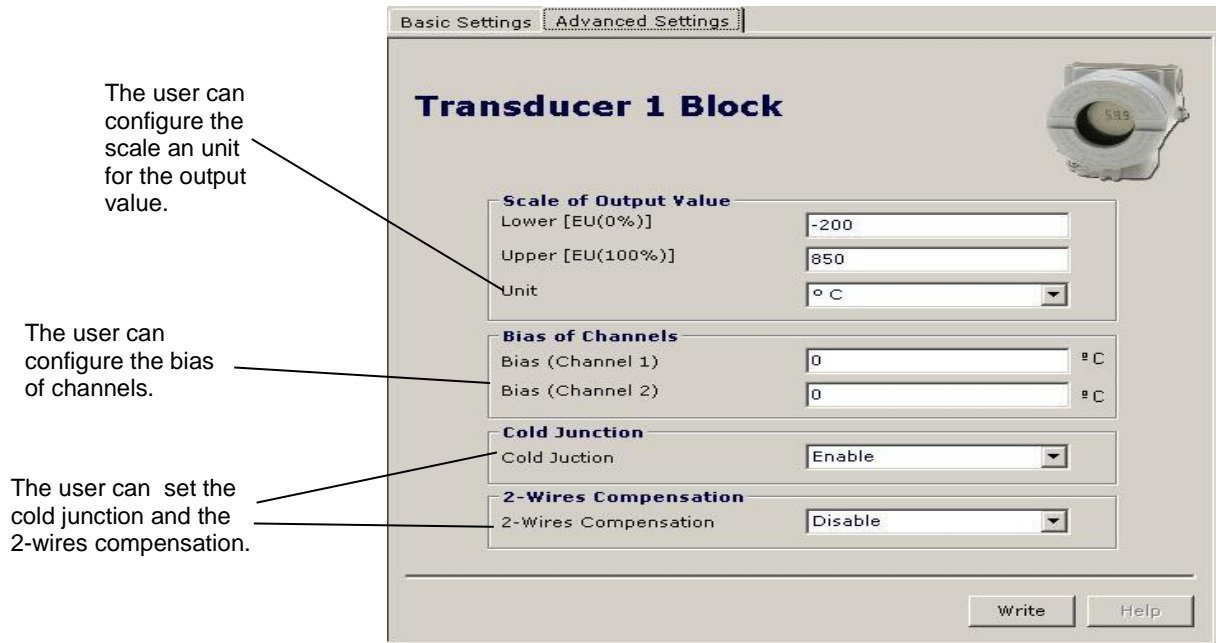

Figure 3.6 – Profibus View - Transducer Advanced Settings

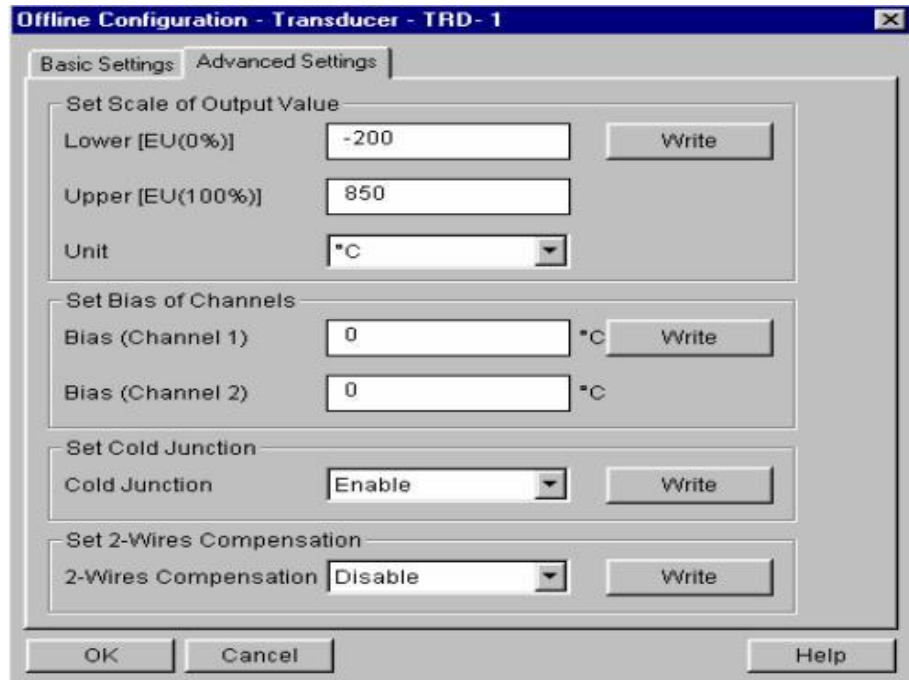

Figure 3.7 – PDM Simatic - Offline Configuration - Transducer Advanced Settings

Sensor Transducer Number

The Sensor Transducer Number associates the sensor to the transducer. It can be set to channel one up to channel two, in case of dual sensor.

Jumper Configuration

In order to work properly, the jumpers J1 and J3 located in the **TT303** main board must be correctly configured.

J1 is responsible to enable the AI block simulate mode.

W1 is responsible to enable the local adjustment.

NOTE

There are no 3 or 4 wire connections for millivoltage sensors.

SENSOR_TYPE
Pt 100 IEC
Pt 100 JIS
Pt 500 IEC
Ni 120 DIN
Cu 10 CE
Pt 50 IEC
Pt 50 JIS
Ohm 100
Ohm 400
Ohm 2,000
TC B NBS
TC E NBS
TC J NBS
TC K NBS
TC N NBS
TC R NBS
TC S NBS
TC T NBS
TC L DIN
TC U DIN
mV 22
mV 100
mV 500

Table 3.3 - Sensor Type Table

CONNECTION
DOUBLE TWO WIRE
TWO WIRE
THREE WIRE
FOUR WIRE

Table 3.4 - Type of Connection Table

How to Connect Two Sensors



Transmitter series **TT303** are capable of operating simultaneously with two sensors, using two transducer blocks, if necessary. Configuration types in two sensors operation are as follows:

Differential – In this case there is only one transducer. Transducer output is the difference between the readout of sensor 1 (between terminals 3 and 4) and the readout of sensor 2 (between terminals 2 and 4).

Backup - In this case there is only one transducer.

If the first sensor (connected between terminals 3 and 4) opens, the second sensor (connected between terminals 2 and 4) will supply the signal to the transducer.

Process Temperature - In this case there are two transducers. Each sensor provides a signal to its respective transducer. In this case, please select the sensor connection to "2 dual wires".

In order to be able to operate with sensors in the backup or differential modes, the user shall actuate parameter **MEASURED_TYPE**. In order to operate with double sensors, the user shall actuate parameter **SENSOR_CONNECTION**. Please see figure 3.4 e 3.5.

Compensation of Line Resistance for RTD Double Sensor or Ohm Sensor

TT303 allows connecting two sensors but it is possible just using 2 wires and this can cause an error due to the absence of compensation of line resistance. To minimize this error, there is the **TWO_WIRES_COMPENSATION** parameter that enables the calculation of line resistance.

To make the compensation it is necessary to set RTD or Ohm with 2 dual wires in the **LIN_TYPE** parameter (relative index 14) and then make a short circuit between 1 and 3 terminals. After that it is necessary to make a short circuit between 3 and 4 terminals (in the wires in the sensor location). Then enable the **TWO_WIRES_COMPENSATION** parameter (relative index 73). After that, verify the **PRIMARY_VALUE** parameter.

Repeat the same procedure for the second transducer, keeping the short circuit between 1 and 3 terminals, but making a short circuit between 2 and 4 terminals. Please see figure 3.6 e 3.7.

Compensation of Cold Junction

TT303 allows the compensation of cold junction when the user select "Enable" according to the Figure 3.6 e 3.7.

Calibration in TT303 by the User

The electronics of **TT303** is very stable in time, not requiring further calibrations after manufacturer's calibration. However, should the client decide to use his reference to calibrate the **TT303** (which is not recommendable), this may be done by means of parameters **CAL_POINT_LO** and **CAL_POINT_HI**. When trim is performed, always use two points as reference; never consider only one point as a reference. Using **Profibus View** or the **Simatic PDM**, the calibration is done selecting at the main menu "Calibration - Transducer TRD1-Lower/Upper" or menu Calibration - Transducer TRD2-Lower/Upper".

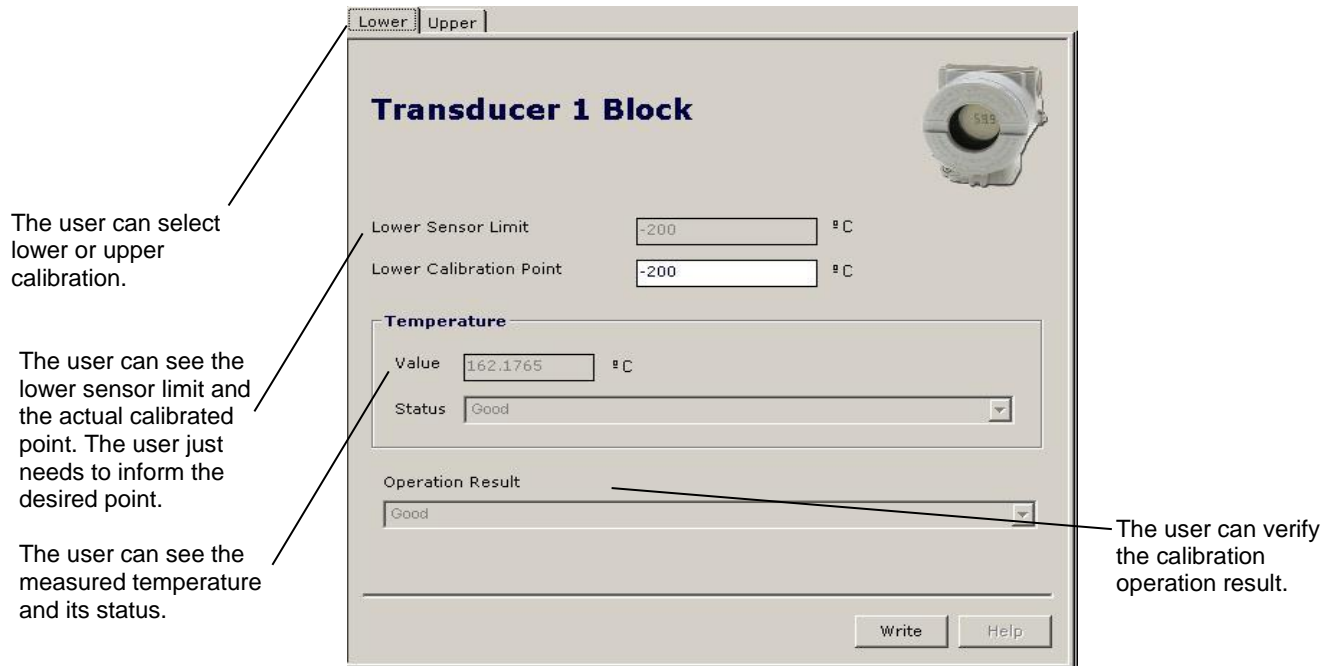

Figure 3.8 – Profibus View - Lower Calibration Procedures

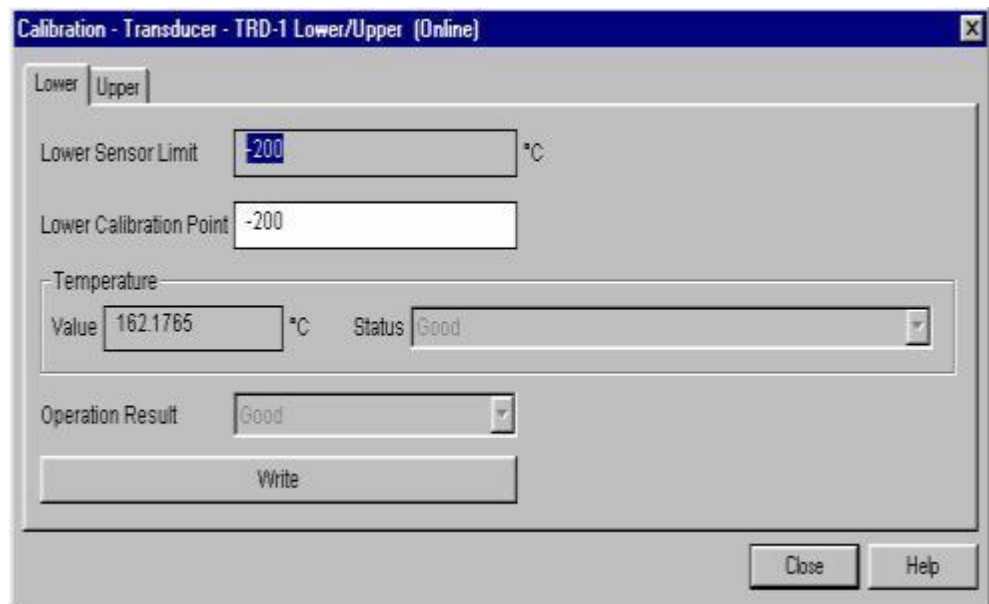

Figure 3.9 – PDM Simatic - Lower Calibration Procedure

If the user to select the upper page (UPPER):

The user can see the upper sensor limit and the actual calibrated point. The use just needs to inform the desired

The user can verify the calibration operation result.

The user can see the measured temperature and its status.

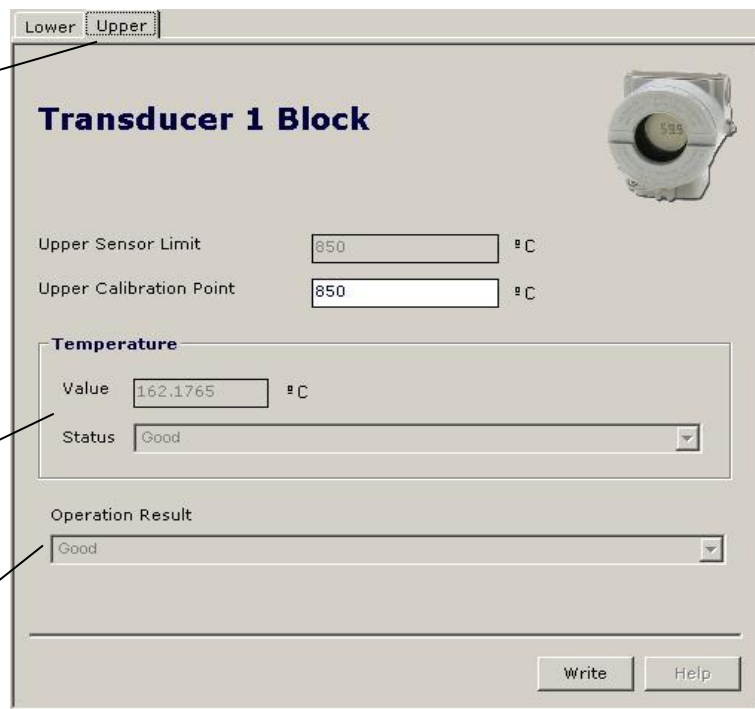

Figure 3.10 – Profibus View - Upper Calibration Procedures

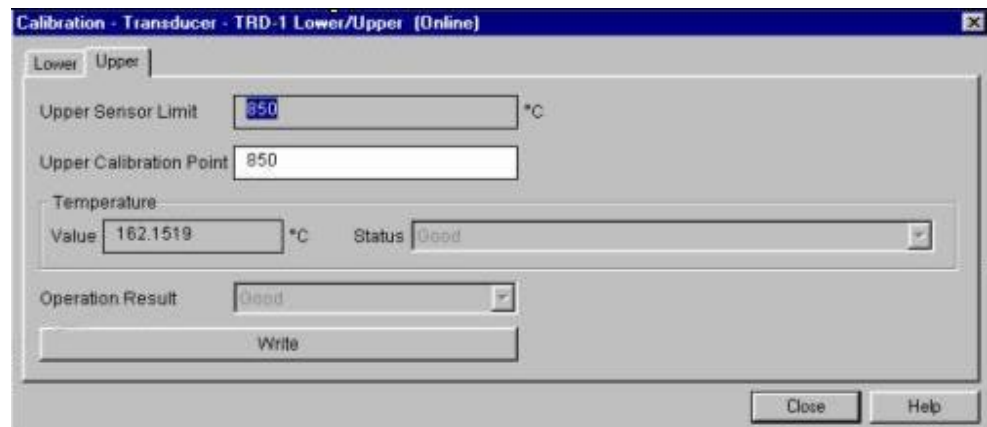

Figure 3.11 – PDM Simatic - Upper Calibration Procedure

NOTE

Every time the sensor is altered, TRIM values are reset. In the case of TC it is necessary to disable the cold junction compensation before starting calibration procedures. Trim is not available for TT using two sensors.

How to Configure the Analog Input Block



The Analog Input block takes the input data from the Transducer block, selected by channel number, and makes it available to other function blocks at its output. The transducer block provides the input unit of the Analog Input, and when the unit is changed in the transducer, the PV_SCALE unit is changed too. Optionally, a filter may be applied in the process value signal, whose time constant is PV_FTIME. Considering a step change to the input, this is the time in seconds to the PV reaches 63.2% of the final value. If the PV_FTIME value is zero, the filter is disabled. For more details, please, see the Function Blocks Specifications. To configure the Analog Input Block, please, select the Analog Input Block, in the main menu. Select the analog block according to the application. Using this window, the user can configure the block mode operation, selects the channel, scales and unit for input and output value and the damping.

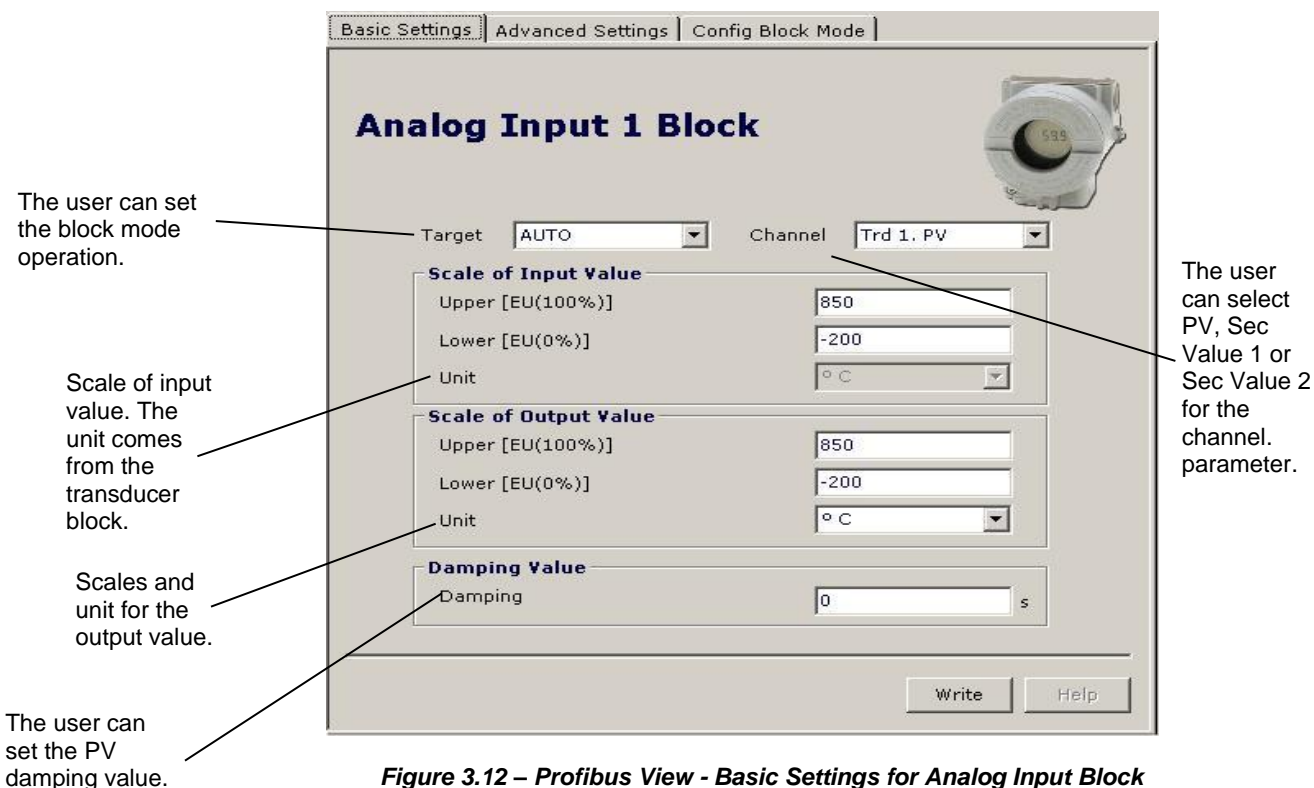

Figure 3.12 – Profibus View - Basic Settings for Analog Input Block

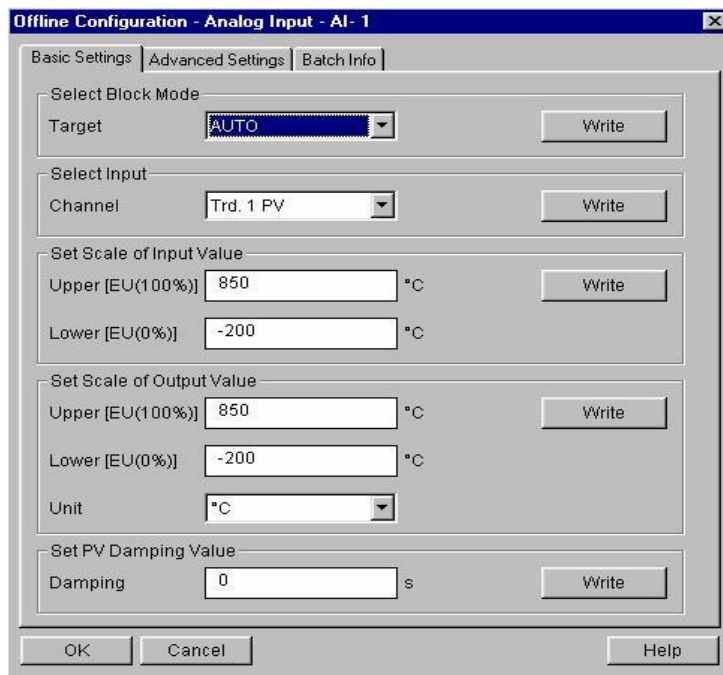

Figure 3.13 – PDM Simatic - Basic Settings for Analog Input Block

Selecting the page "Advanced Settings", the user can configure the conditions for alarms and warnings, as well the fail safe condition. Please, see the window:

The user can set Alarm/Warning limits.

The fail safe conditions.

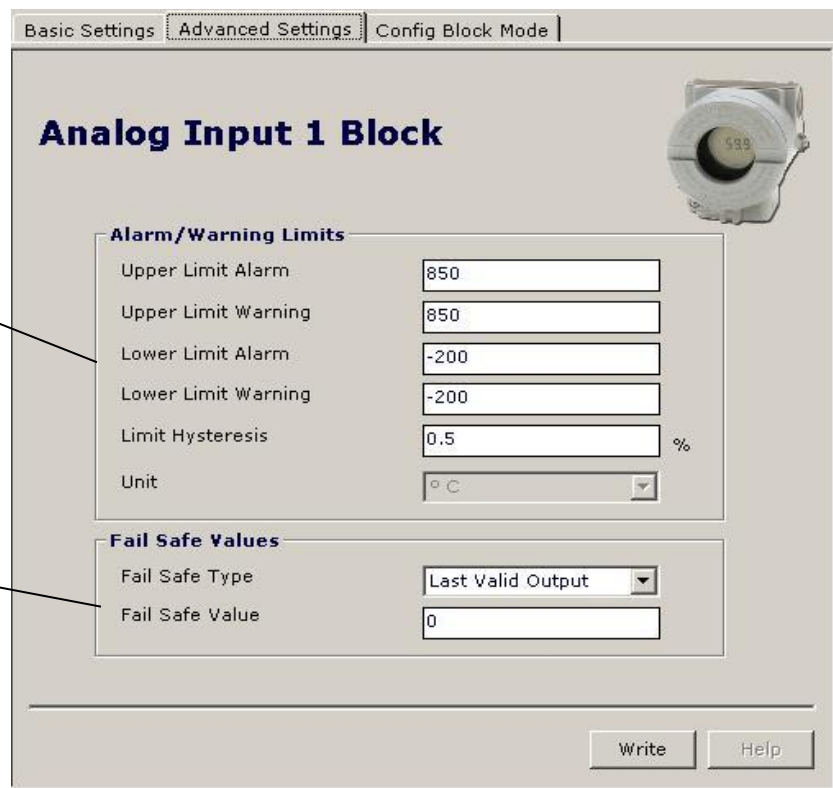

Figure 3.14 – Profibus View - Advanced Settings for Analog Input Block

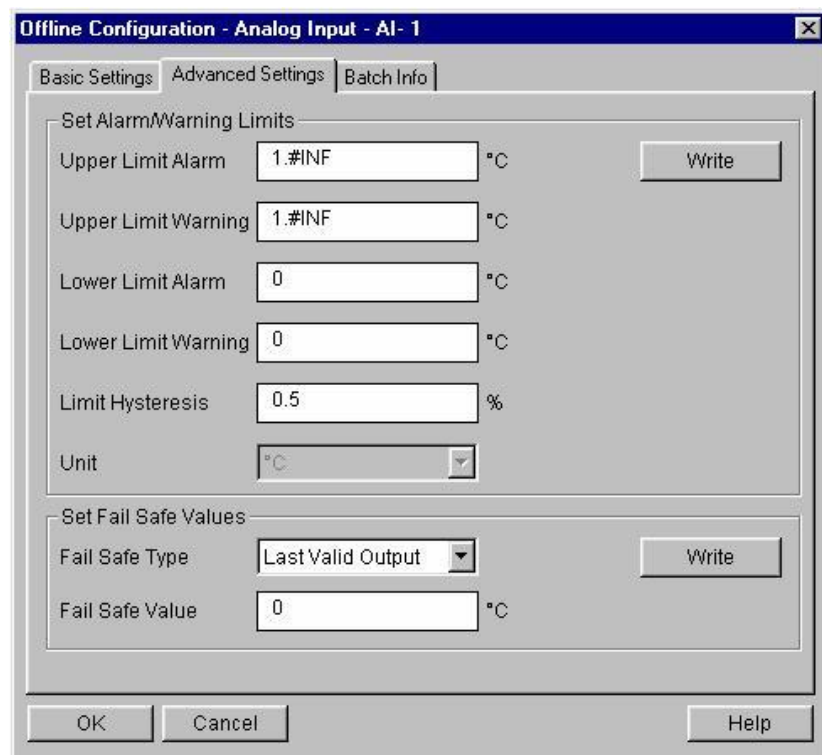

Figure 3.15 – PDM Simatic - Advanced Settings for Analog Input Block

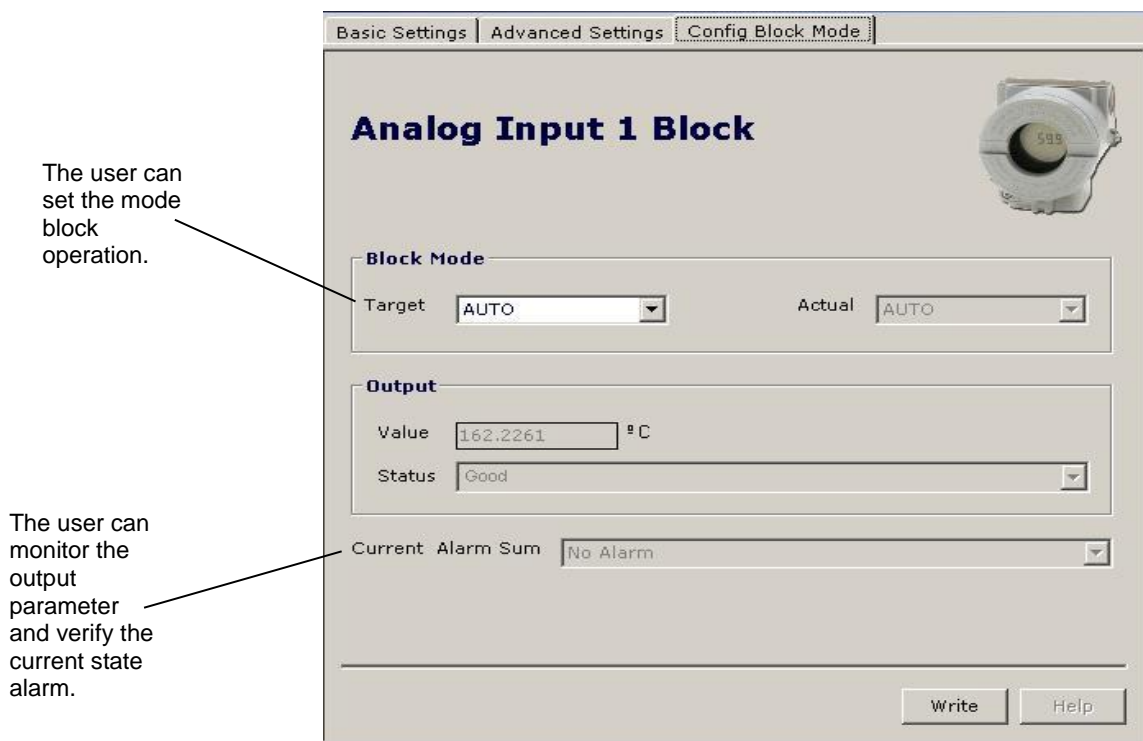

Figure 3.16 – Profibus View - Analog Input Block

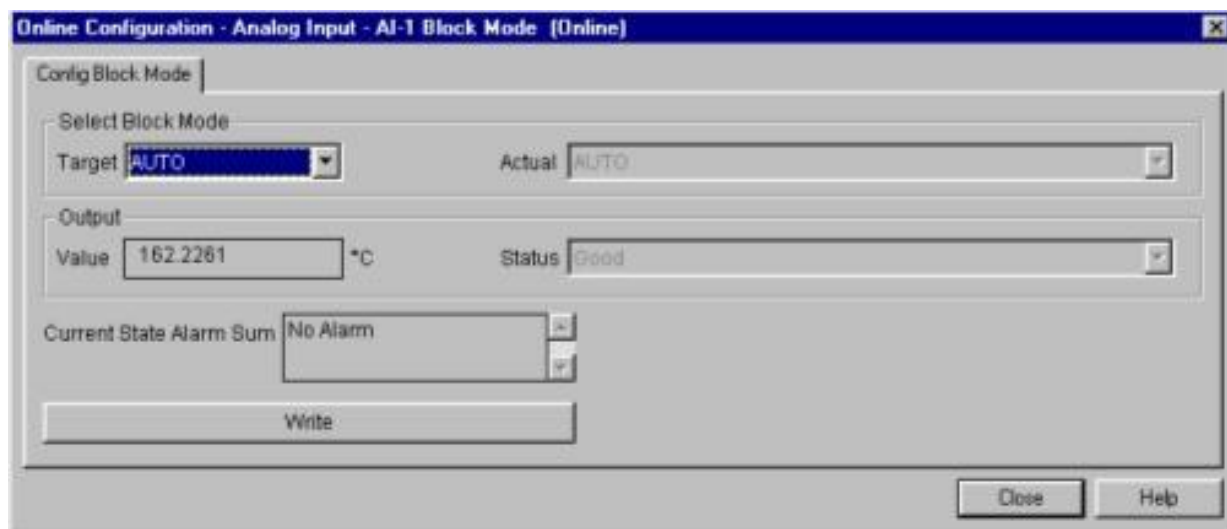

Figure 3.17 – PDM Simatic - Online Configuration for Analog Input Block

Programming Using Local Adjustment

The local adjustment is completely configured by **Profibus View** or **Simatic PDM** or **any other configuration tool**. It means that the user can select the best options to fit his application. From factory, it is configured with the options to set the Upper and Lower trim, for monitoring the input transducer output and check the Tag. Normally, the transmitter is much better configured by **configuration tool**, but the local functionality of the LCD permits an easy and fast action on certain parameters, since it does not rely on communication and network wiring connections. Among the possibilities by Local Adjustment, the following options can be emphasized: Mode Block, Outputs Monitoring, Tag Visualization and Tuning Parameters Setting.

User's interface is also described very detailed on the "General Installation, Operation and Maintenance Procedures Manual". Please take a detailed look at this manual in the chapter related to "Programming Using Local Adjustment". The resources on this transducer display are very significant, and all of the Series 303 field devices from SMAR has the same methodology to handle with it. So, since the user has learned once, he is capable to handle all kind of field devices from SMAR. This Local Adjustment is a suggestion only. The user may choose his preferred configuration via configuration toll, simply setting the display block).

The positioner has two holes for magnetic switches, located under the identification plate. These magnetic switches are activated by a magnetic tool.

This magnetic tool enables adjustment of the most important parameters of the blocks. It also enables pre-configuration of the communication.

The jumper W1 on top of the main circuit board must be in place and the positioner must be fitted with digital display for access to the local adjustment. Without display, the local adjustment is not possible.

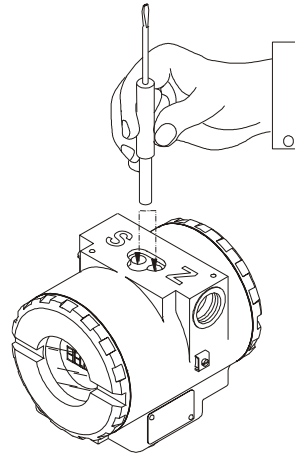

Figure 3.18 - Local Adjustment Holes

Table 3.5 shows the actions on the **Z** and **S** holes on the **TT303** when Local Adjustment is enabled.

HOLE	ACTION
Z	Initializes and rotates through the available functions.
S	Selects the function shown in the display.

Table 3.5 - Purpose of the holes on the Housing

Local Adjustment Tree - Quick Guide

Local Adjustment tree – Quick Guide

1) HOW TO ACCESS LOCAL ADJUSTMENT TREE

Follow Steps:
 1) Insert magnetic screw driver in zero hole;
 2) Wait 3 seconds;
 3) Insert magnetic screw driver in span hole;
 4) Wait 3 seconds, then MD will appear on display.

2) HOW TO BROWSE AND SELECT MENU OPTIONS

Browse: Insert magnetic screw driver in zero hole and hold.
Select: Insert magnetic screw driver in span hole and hold.

3) HOW TO CONFIGURE A BLOCK PARAMETER

1) Browse until CONF option, select LCD2;
 2) Browse until BLOCK select the block that will be configured;
 3) Browse until PRMT and set the relative index of the parameter;
 4) Browse until ITEM and set the sub index (if applicable);
 5) Browse until UPDT, insert magnetic screw driver in Zero Hole;
 6) Reenter in Local Adjustment, browse until LCD2, now the parameter is available to change;
 7) Repeat above steps for all the parameters to be configured.

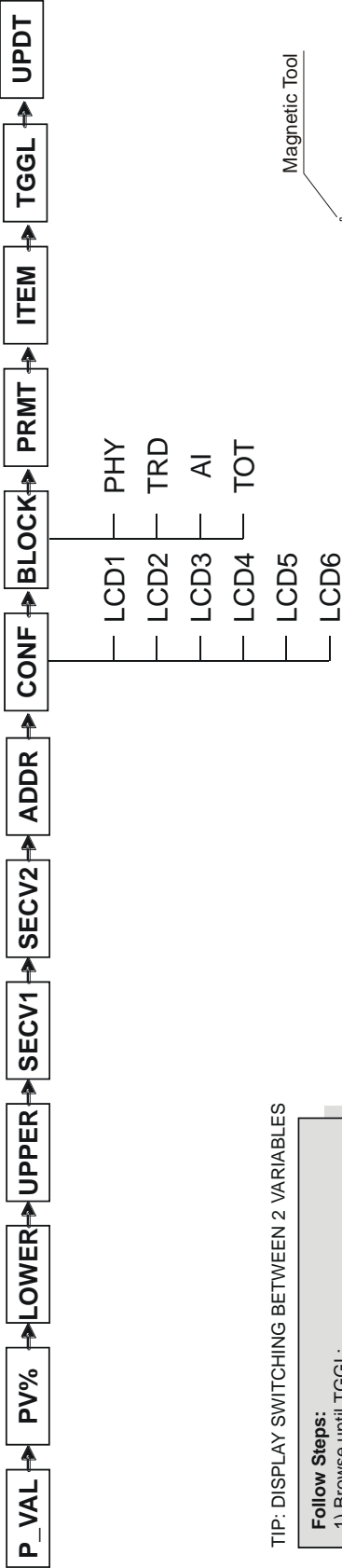

TIP: DISPLAY SWITCHING BETWEEN 2 VARIABLES

Follow Steps:
 1) Browse until TGGL;
 2) Select 2;
 3) Configure LCD 2 with the desired parameter.

With TOGGLE 6

LCD1	LCD2	LCD3	LCD4	LCD5	LCD6
PVAL	SEC2	LOWER	UPPER	SEC1	SEC2
18	31	12	11	29	31

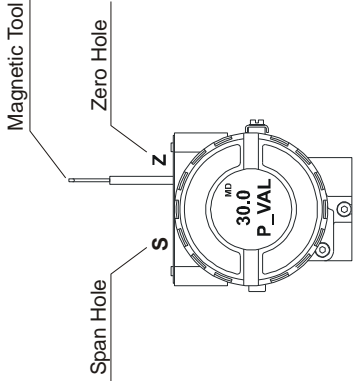

- CONF: option where it is possible to select the LCD to configure. Six options are available: from LCD1 up to LCD6;
- BLOCK: option where the user must select the function block that he desires to configure;
- PRMT: number correspondent to the relative index of the desired parameter into the chosen function block;
- ITEM: configure this option when a selected parameter has sub items to be configured, for example, the OUT_SCALE parameter is compounded by "EU at 100%", "EU at 0%", "Unit Index" and "Decimal Point";
- TGGL (Toggle): switches from 1 up to 6 configured parameters on the display. If TGGL is equal to 2, for example, the display will switch between LCD1 and LCD2;
- UPDT: refreshes the display when one of the LCDs are configured. Finalize display configuration by setting "UPDT", after choosing the configuration for the local adjustment.

J1 Jumper Connections

If J1 (see figure 3.14) is connected to ON, then simulation mode in the AI block is enabled.

W1 Jumper Connections

If W1 is connected to ON, the local adjustment programming tree is enabled and then important block parameters can be adjusted and communication can be pre-configured via local adjustment.

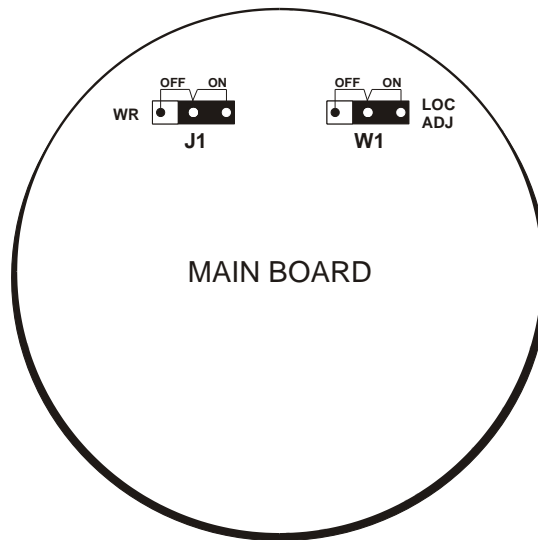
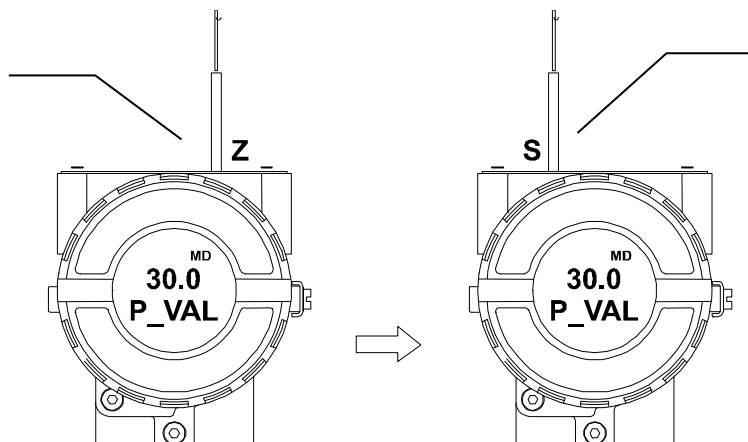

Figure 3.19 - J1 and W1 Jumpers

Local Programming Tree

In order to start the local adjustment, place the magnetic tool in orifice **Z** and wait until letters **MD** are displayed.



Place the magnetic tool in orifice **S** and wait during 5 seconds.

Figure 3.20 - Step 1 - TT303

Remove the magnetic tool from orifice **S**.

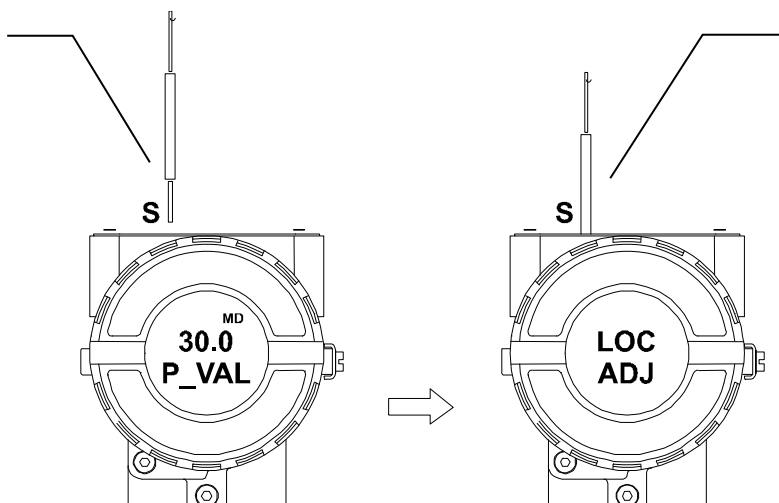

Insert the magnetic tool in orifice **S** once more and **LOC ADJ** should be displayed.

Figure 3.21 - Step 2 - TT303

Place the magnetic tool in orifice **Z**. In case this is the first configuration, the option shown on the display is the TAG with its corresponding mnemonic configured by the CONFIGURATION TOOL. Otherwise, the option shown on the display will be the one configured in the prior operation. By keeping the tool inserted in this orifice, the local adjustment menu will rotate.

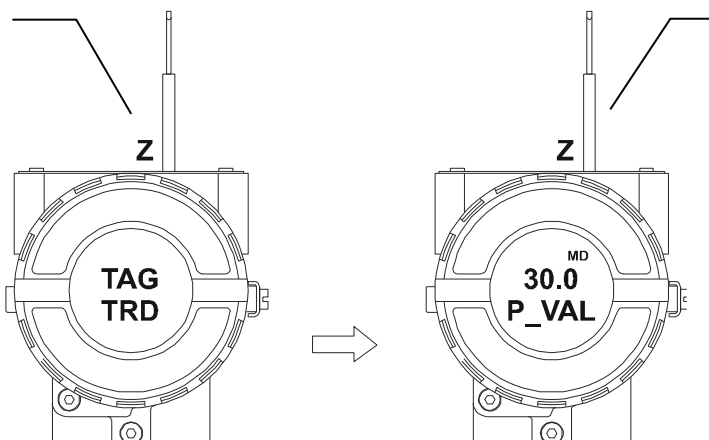

In this option the first variable (**P_VAL**) is showed with its respective value (if you to want that it keep static, put the tool in **S** orifice and stay there).

Figure 3.22 - Step 3 - TT303

In order to range the lower value(lower), simply insert the magnetic tool in orifice **S** as soon as LOWER is shown on the display. An arrow pointing upward (↑) increments the valve and an arrow pointing downward (↓) decrements the value. In order to increment the value, keep the tool insert in **S** up to set the value desired.

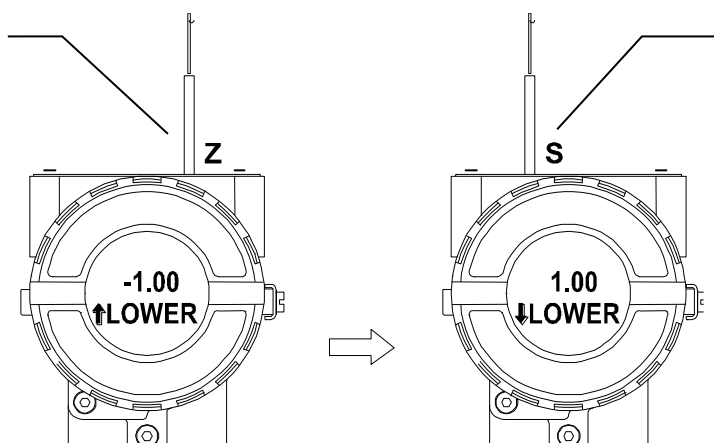

In order to decrement the lower value, place the magnetic tool in orifice **Z** to shift the arrow to the downward position and then, by inserting and keeping the tool in orifice **S**, it is possible to decrement the lower value.

Figure 3.23 - Step 4 - TT303

In order to range the upper value(upper), simply insert the magnetic tool in orifice **S** as soon as upper is shown on the display. An arrow pointing upward (↑) increments the value and an arrow pointing downward (↓) decrements the value. In order to increment the value, keep the tool insert in **S** up to set the value desired.

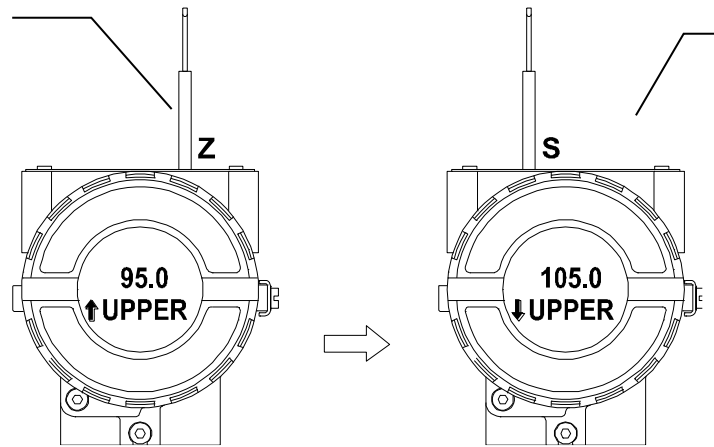

In order to decrement the upper value, place the magnetic tool in orifice **Z** to shift the arrow to the downward position an then, by inserting and keeping the tool in orifice **S**, it is possible to decrement the upper value.

Figure 3.24 – Step 5 - TT303

a) In order to change the address value, simply take off the magnetic tool from orifice **Z** as soon as ADDR is shown on the display. An arrow pointing upward (↑) increments the address and an arrow pointing downward (↓) decrements the address. In order to increment the address, insert the tool in **S** up to set the value desired.

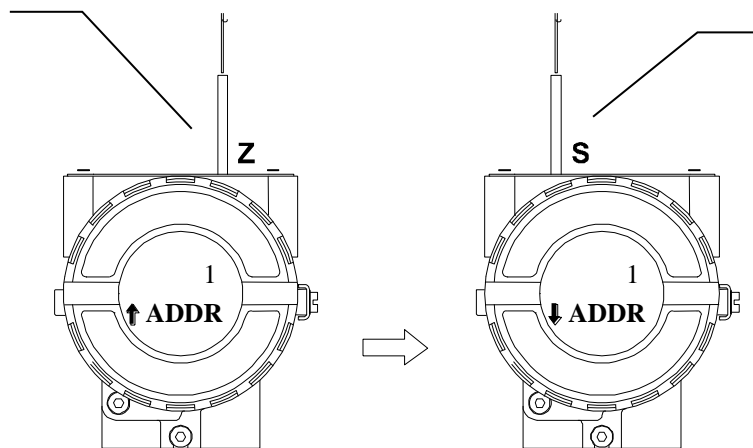

In order to decrement the address value, place the magnetic tool in orifice **Z** to shift the arrow to the downward position and then, by inserting and keeping the tool in orifice **S**, it is possible to decrement the address value.

Figure 3.25 - Step 6 - TT303

Transducer Display – Configuration

Using the **Profibus View** or **Simatic PDM** is possible to configure the Display Transducer block. As the name described it is a transducer due the interfacing of its block with the LCD hardware.

The Transducer Display is treated as a normal block by any configuration tool. It means, this block has some parameters and those ones can be configured according to customer's needs.

The customer can choose up to six parameters to be shown at LCD display; they can be parameters just for monitoring purpose or for acting locally in the field devices by using a magnetic tool. The seventh parameter is used to access the physical device address. The user can change this address according to his application. To access and configure the Display Block, please, select "Device OnLine Configuration - Display Block", in the main menu:

Figure 3.26 – Profibus View - Display Block

Figure 3.27 – PDM Simatic - Display Block

Display Transducer Block

The local adjustment is completely configured by **Profibus View** or **Simatic PDM**. It means, the user can select the best options to fit his application. From factory, it is configured with the options to set the Upper and Lower trim, for monitoring the input transducer output and check the Tag. Normally, the transmitter is much better configured by **Profibus View** or **Simatic PDM**, but the local functionality of the LCD permits an easy and fast action on certain parameters, since it does not rely on communication and network wiring connections. Among the possibilities by Local Adjustment, the following options can be emphasized: Mode block, Outputs monitoring, Tag visualization and Tuning Parameters setting.

The interface between the user is described very detailed on the "General Installation, Operation and Maintenance Procedures Manual". Please take a detailed look at this manual in the chapter related to "Programming Using Local Adjustment". The resources on this transducer display are very significant, and all of the Series 303 field devices from SMAR have the same methodology to handle with it. So, since the user has learned once, he is capable to handle all kind of field devices from SMAR.

All function blocks and transducers defined according Profibus PA have a description of their features written by the Device Description Language.

This feature permits those third parties configuration tools enabled by Device Description Service technology can interpret these features and make them accessible to configure. The Function Blocks and Transducers of Series 303 have been defined rigorously according the Profibus PA specifications in order to be interoperable to other parties.

In order to enable the local adjustment using the magnetic tool, it is necessary to previously prepare the parameters related with this operation via System Configuration.

There are six groups of parameters, which may be pre-configured by the user in order to able, a possible configuration by means of the local adjustment. As an example, let's suppose that you don't want to show some parameters; in this case, simply select "None" in the parameter, "Select Block Type". Doing this, the device will not take the parameters related (indexed) to its Block as a valid parameter.

Definition of Parameters and Values

Select Block Type

This is the type of the block where the parameter is located. The user can choose: Transducer Block, Analog Input Block, Totalizer Block, Physical Block or None.

Select/Set Parameter Type/Index

This is the index related to the parameter to be actuated or viewed (0, 1, 2...). For each block there are some pre-defined indexes. Refer to the Function Blocks Manual to know the desired indexes and then just enter the desired index.

Set Mnemonic

This is the mnemonic for the parameter identification (it accepts a maximum of 16 characters in the alphanumeric field of the display). Choose the mnemonic, preferably with no more than 5 characters because, this way, it will not be necessary to rotate it on the display.

Set Decimal Step

It is the increment and decrement in decimal units when the parameter is Float or Float Status value, or integer, when the parameter is in whole units.

Set Decimal Point Place

This is the number of digits after the decimal point (0 to 3 decimal digits).

Set Access Permission

The access allows the user to read, in the case of the "Monitoring" option, and to write when "Action" option is selected, then the display will show the increment and decrement arrows.

Set Alpha Numerical

These parameters include two options: value and mnemonic. In option value, it is possible to display data both in the alphanumeric and in the numeric fields; this way, in the case of a data higher than 10000, it will be shown in the alphanumeric field.

In the mnemonic option, the display may show the data in the numeric field and the mnemonic in the alphanumeric field.

For devices where the software version is higher or equal to 1.10, please see the "Programming Using Local Adjustment", on this manual.



In case you wish to visualize a certain tag, choose for the index relative equal to "tag". To configure other parameters just select "LCD-II" up to "LCD-VI" windows:

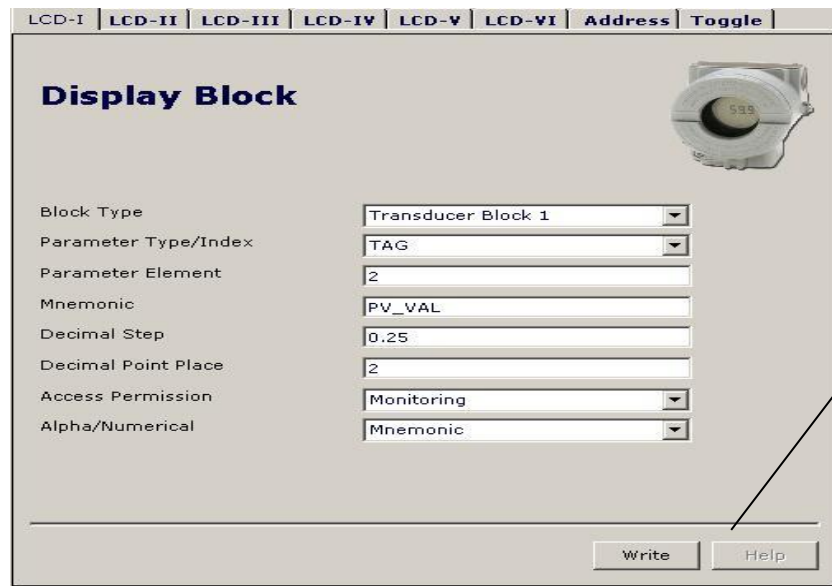

The option "Write" should be selected in order to execute the upgrade of local adjustment programming tree.

After its step all the parameters selected will be shown on the LCD display.

Figure 3.28 – Profibus View - Parameters for Local Adjustment Configuration

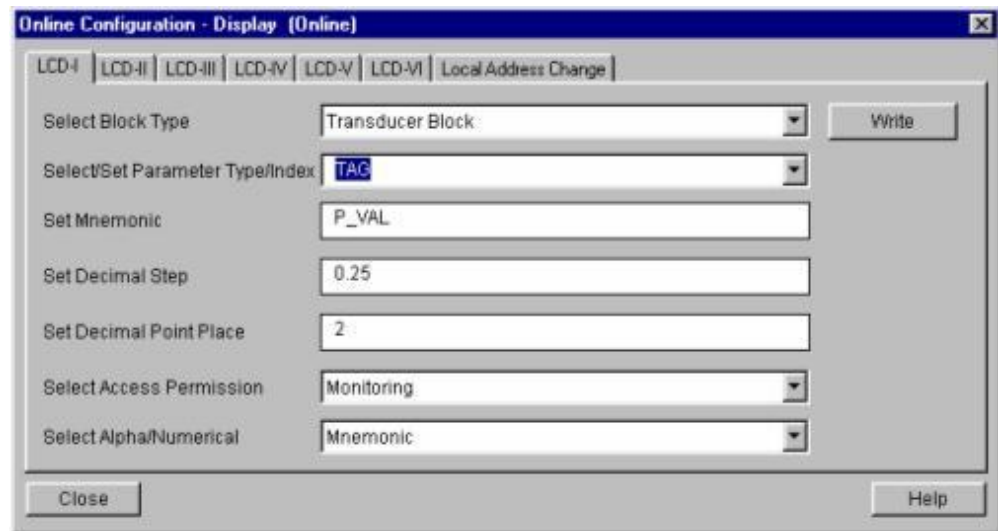

Figure 3.29 – PDM Simatic - Parameters for Local Adjustment Configuration



The window "Local Address Change" allows the user "enable/disable" the access to changing the physical device address.

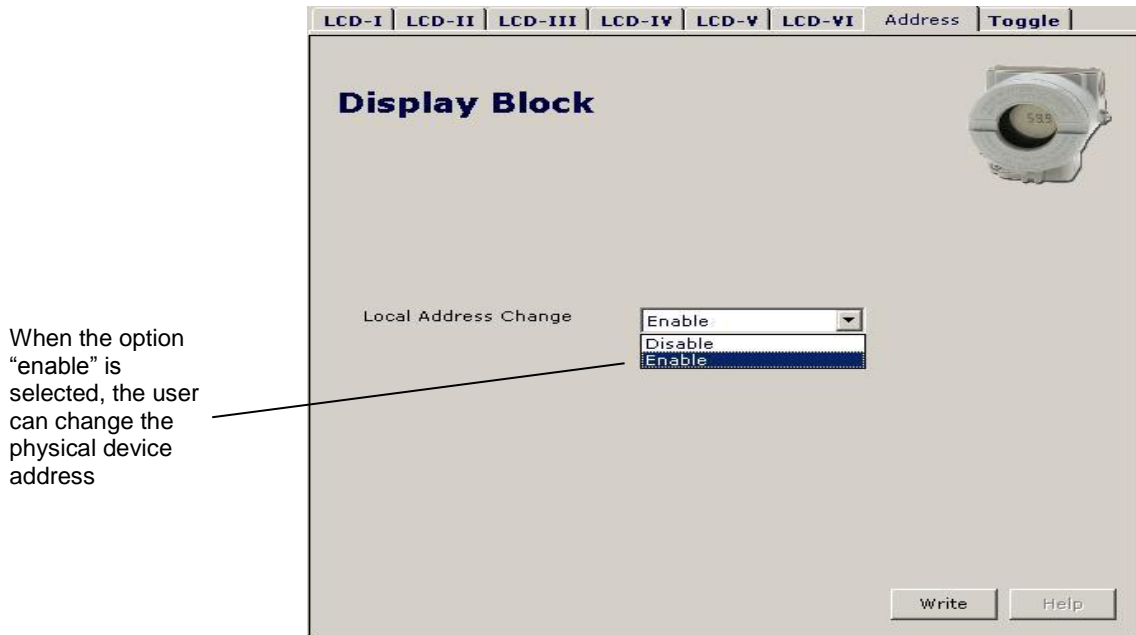

Figure 3.30 – Profibus View - Parameters for Local Adjustment Configuration

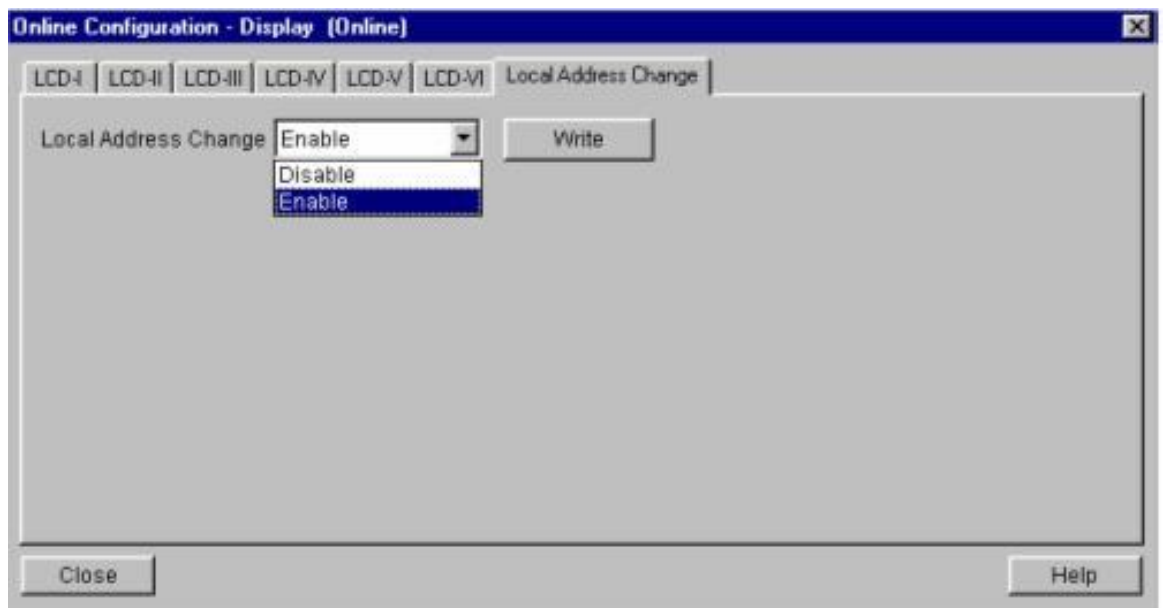

Figure 3.31 – PDM Simatic - Parameters for Local Adjustment Configuration

When the user enter into the local adjustment and rotate the parameters using the magnetic tool, after escaping to normal operation, e.g, the monitoring, if the parameter when the magnetic tool is removed has "Access Permission equal to "monitoring", then this last parameter will be shown at the LCD.

Always on the LCD interface will be shown two parameters at the same time, switching between the configured parameter at the LCD-II and the last monitoring parameter. If the user does not want to show two parameters at the same time, it is only necessary to opt for "none" when configure the LCD-II:

Selecting "None", only the last chosen monitoring parameter will be shown at LCD.

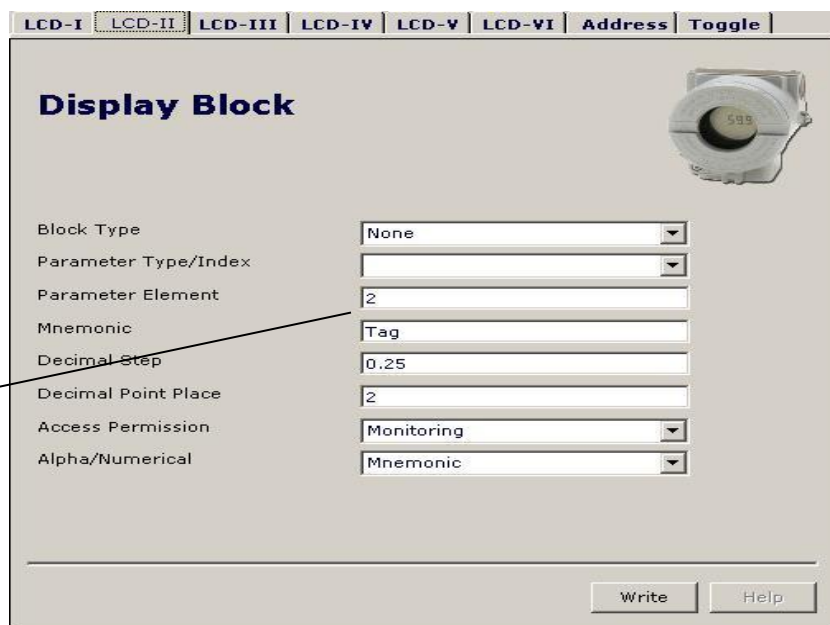

Figure 3.32 – Profibus View - Parameters for Local Adjustment Configuration

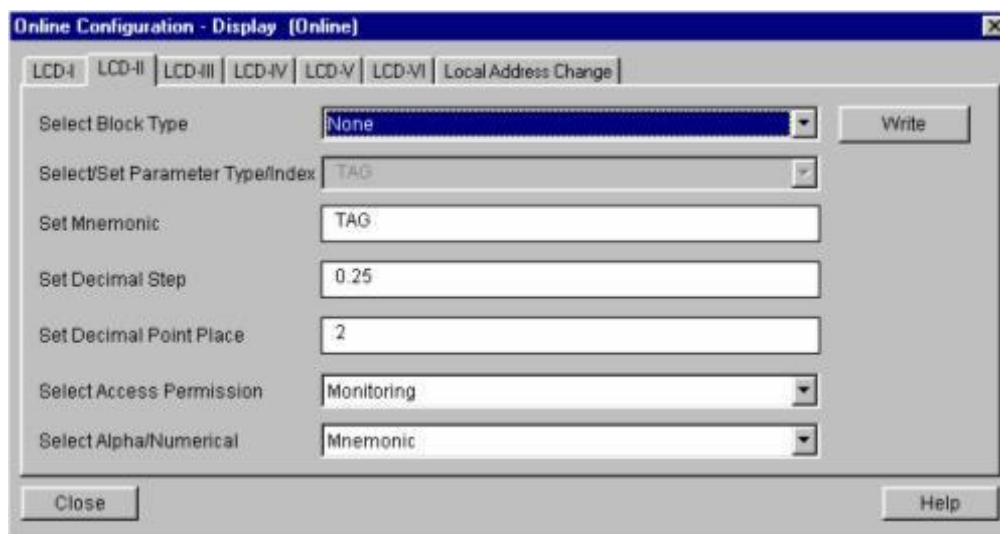

Figure 3.33 – PDM Simatic - Parameters for Local Adjustment Configuration



The user can select the "Mode Block" parameter at the LCD. In this case is necessary to select the index equal to "Mode Block":

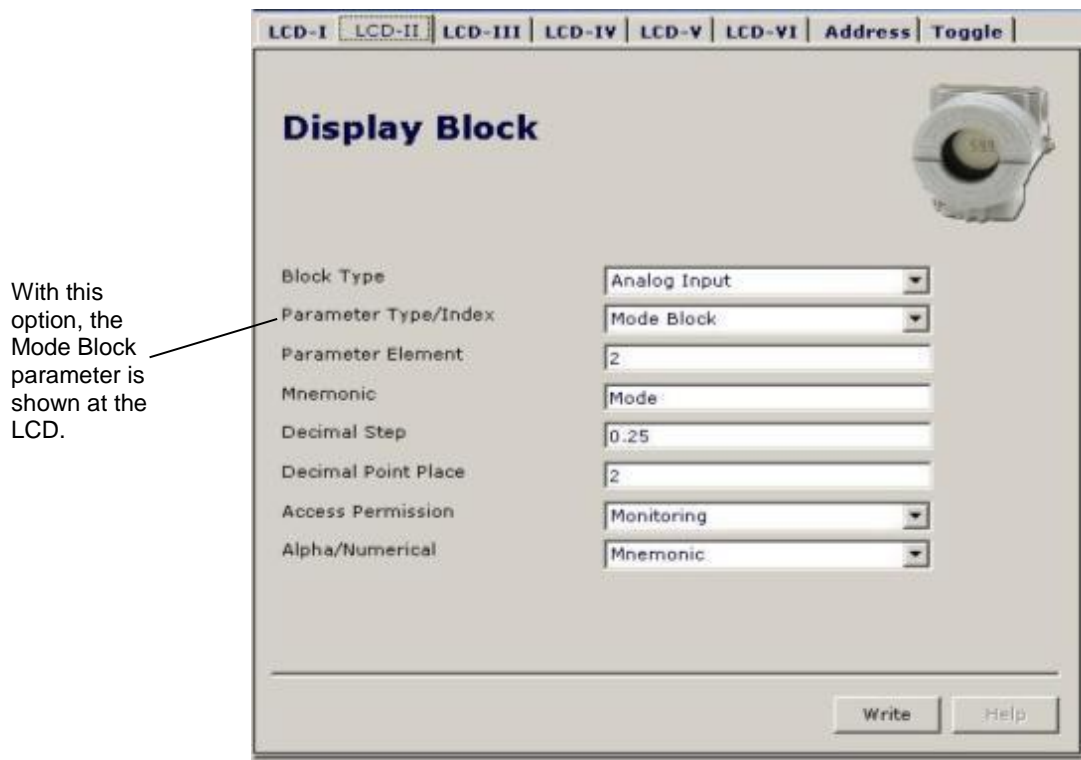

Figure 3.34 – Profibus View - Parameters for Local Adjustment Configuration

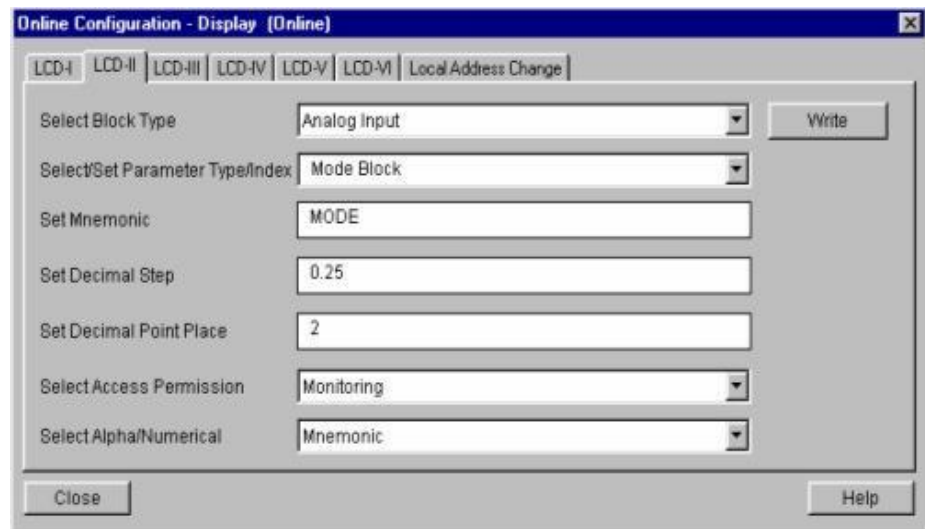

Figure 3.35 – PDM Simatic - Parameters for Local Adjustment Configuration

Cyclical Diagnosis

Via cyclic communication is possible to verify diagnostics from the **TT303** using the Profibus Master Class 1 or even via acyclic communication via Master Class 2. The Profibus-PA devices provide up to 4 standard diagnoses bytes via Physical Block (see figure 3.36 and 3.37) and when the most significant bit of the fourth Byte is "1", the diagnose will extend the information in more 6 bytes. These Diagnosis bytes can also be monitored via cyclic tools.

Len of status bytes	Status Type	Physical Block Slot	Status		From Physical Block	
			Appears	Disappears	Standard Diagnostic	Extended Diagnostic
08 - Standard Diag 0E - Ext Diag	FE	01	01 - Appears 02- Disappears		4 bytes	6 bytes vendor specific

When bit 55 (byte 4, MSB) is "1":
the device has extended diagnostic

Figure 3.36 – Cyclical Diagnosis

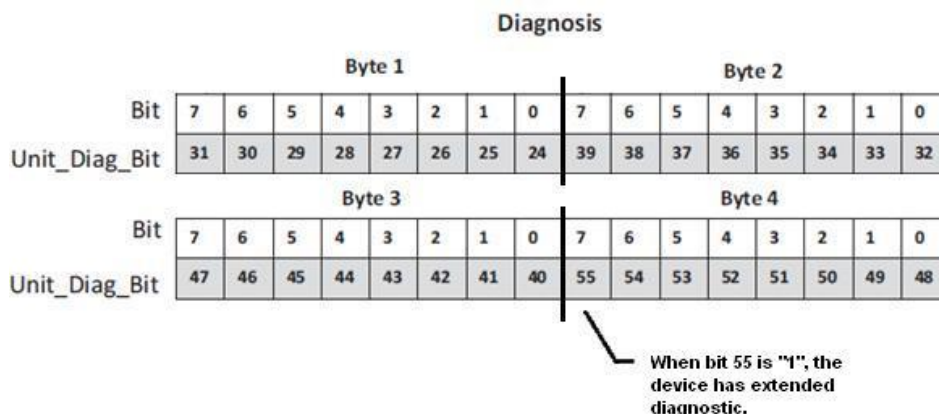

Figure 3.37 – Cyclic Diagnosis mapping for 4 bytes of Physical Block

Unit_Diag_bit is described in the GSD file Profibus-PA device.

See below a description part of a GSD file for the 4 bytes and more detail:

```
;------ Description of device related diagnosis: -----  
;
```

```
Unit_Diag_Bit(16) = "Error appears"  
Unit_Diag_Bit(17) = "Error disappears"  
;  
;Byte 01  
Unit_Diag_Bit(24) = "Hardware failure electronics"  
Unit_Diag_Bit(25) = "Not used 25"  
Unit_Diag_Bit(26) = "Not used 26"  
Unit_Diag_Bit(27) = "Electronic temperature too high"  
Unit_Diag_Bit(28) = "Memory error"  
Unit_Diag_Bit(29) = "Measurement failure"  
Unit_Diag_Bit(30) = "Not used 30"  
Unit_Diag_Bit(31) = "Not used 31"
```

```
;Byte 02  
Unit_Diag_Bit(32) = "Not used 32"  
Unit_Diag_Bit(33) = "Not used 33"  
Unit_Diag_Bit(34) = "Configuration invalid"
```

Unit_Diag_Bit(35) = "Restart"
Unit_Diag_Bit(36) = "Coldstart"
Unit_Diag_Bit(37) = "Maintenance required"
Unit_Diag_Bit(38) = "Not used 38"
Unit_Diag_Bit(39) = "Ident_Number violation"

;Byte 03
Unit_Diag_Bit(40) = "Not used 40"
Unit_Diag_Bit(41) = "Not used 41"
Unit_Diag_Bit(42) = "Not used 42"
Unit_Diag_Bit(43) = "Not used 43"
Unit_Diag_Bit(44) = "Not used 44"
Unit_Diag_Bit(45) = "Not used 45"
Unit_Diag_Bit(46) = "Not used 46"
Unit_Diag_Bit(47) = "Not used 47"

;byte 04
Unit_Diag_Bit(48) = "Not used 48"
Unit_Diag_Bit(49) = "Not used 49"
Unit_Diag_Bit(50) = "Not used 50"
Unit_Diag_Bit(51) = "Not used 51"
Unit_Diag_Bit(52) = "Not used 52"
Unit_Diag_Bit(53) = "Not used 53"
Unit_Diag_Bit(54) = "Not used 54"
Unit_Diag_Bit(55) = "Extension Available"

;Byte 05 TRD 01 Block & PHY Block
Unit_Diag_Bit(56) = "Sensor failure"
Unit_Diag_Bit(57) = "Secondary Value (body device temperature) is in failure"
Unit_Diag_Bit(58) = "Primary Value Type is Backup-sensor and the Backup-Sensor is active"
Unit_Diag_Bit(59) = "Not used 59"
Unit_Diag_Bit(60) = "Not used 60"
Unit_Diag_Bit(61) = "Not used 61"
Unit_Diag_Bit(62) = "Calibration Error - Check XD_ERROR parameter for TRD 1 or TRD 2"
Unit_Diag_Bit(63) = "Device is writing lock"

;byte 06 AI_1 Block
Unit_Diag_Bit(64) = "Simulation Active in AI 1 Block"
Unit_Diag_Bit(65) = "Fail Safe Active in AI 1 Block"
Unit_Diag_Bit(66) = "AI 1 Block in Out of Service"
Unit_Diag_Bit(67) = "AI 1 Block Output out of High limit"
Unit_Diag_Bit(68) = "AI 1 Block Output out of Low limit"
Unit_Diag_Bit(69) = "Not used 69"
Unit_Diag_Bit(70) = "Not used 70"
Unit_Diag_Bit(71) = "Not used 71"

;byte 07 AI_2 Block
Unit_Diag_Bit(72) = "Simulation Active in AI 2 Block"
Unit_Diag_Bit(73) = "Fail Safe Active in AI 2 Block"
Unit_Diag_Bit(74) = "AI 2 Block in Out of Service"
Unit_Diag_Bit(75) = "AI 2 Block Output out of High limit"
Unit_Diag_Bit(76) = "AI 2 Block Output out of Low limit"
Unit_Diag_Bit(77) = "Not used 77"
Unit_Diag_Bit(78) = "Not used 78"
Unit_Diag_Bit(79) = "Not used 79"

;byte 08
Unit_Diag_Bit(80) = "Sensor 1 Failure"
Unit_Diag_Bit(81) = "Sensor 2 Failure"
Unit_Diag_Bit(82) = "Sensor 1 failed and PV comes from Sensor 2"
Unit_Diag_Bit(83) = "Not used 83"
Unit_Diag_Bit(84) = "Not used 84"
Unit_Diag_Bit(85) = "Not used 85"

Unit_Diag_Bit(86) = "Not used 86"

Unit_Diag_Bit(87) = "Not used 87"

;byte 09

Unit_Diag_Bit(88) = "Not used 88"

Unit_Diag_Bit(89) = "Not used 89"

Unit_Diag_Bit(90) = "Not used 90"

Unit_Diag_Bit(91) = "Not used 91"

Unit_Diag_Bit(92) = "Not used 92"

Unit_Diag_Bit(93) = "Not used 93"

Unit_Diag_Bit(94) = "Not used 94"

Unit_Diag_Bit(95) = "Not used 95"

;byte 10

Unit_Diag_Bit(96) = "Not used 96"

Unit_Diag_Bit(97) = "Not used 97"

Unit_Diag_Bit(98) = "Not used 98"

Unit_Diag_Bit(99) = "Not used 99"

Unit_Diag_Bit(100) = "Not used 100"

Unit_Diag_Bit(101) = "Not used 101"

Unit_Diag_Bit(102) = "Not used 102"

Unit_Diag_Bit(103) = "Not used 103"

NOTE

If the FIX flag is active on LCD, the **TT303** is configured to "Profile Specific" mode. When in "Manufacturer Specific" mode, the Identifier Number is 0x089A. Once the Identifier_Number_Selector is changed from "Profile Specific" to "Manufacturer Specific" or vice-versa, one must wait 5 seconds while is saved. Then, turn the **TT303** off and turn it on again. So, the Identifier Number is updated to the communication level. If the equipment is in "Profile Specific" and using the GSD file Identifier Number equals 0x089A, the acyclic communication will work with the tools based on EDDL, FDT/DTM, but no cyclic communication with the Profibus-DP master.

Section 4

MAINTENANCE PROCEDURES

Troubleshooting

SMAR TT303 transmitters are extensively tested and inspected before delivery to the end user. Nevertheless, during their design and development, consideration was given to the possibility of repairs being made by the end user, if necessary.

In general, it is recommended that end users do not try to repair printed circuit boards. Spare circuit boards may be ordered from **SMAR** whenever necessary.

SYMPTOM	PROBABLE SOURCE OF PROBLEM
NO COMMUNICATION	<ul style="list-style-type: none"> ▪ Transmitter Connections Check wiring polarity and continuity. Check for shorts or ground loops. Check if the power supply connector is connected to main board. Check if the shield is not used as a conductor. It should be grounded at one end only.
	<ul style="list-style-type: none"> ▪ Power Supply Check power supply output. The voltage must be between 9 - 32 VDC at the TT303 terminals. Noise and ripple should be within the following limits: a) 16 mV peak to peak from 7.8 to 39 KHz. b) 2 V peak to peak from 47 to 63 Hz for non-intrinsic safety applications and 0.2 V for intrinsic safety applications. c) 1.6 V peak to peak from 3.9 MHz to 125 MHz.
	<ul style="list-style-type: none"> ▪ Network Connection Check that the topology is correct and all devices are connected in parallel. Check that two Terminators are OK and correctly positioned. Check that the coupler connections are OK and correctly positioned. Check that the Terminators are according to the specifications. Check length of trunk and spurs. Check spacing between couplers.
	<ul style="list-style-type: none"> ▪ Network Configuration Make sure that device address is configured correctly.
	<ul style="list-style-type: none"> ▪ Electronic Circuit Failure Check the main board for defect by replacing it with a spare one.
INCORRECT READING	<ul style="list-style-type: none"> ▪ Transmitter Connections Check for intermittent short circuits, open circuits and grounding problems. Check if the sensor is correctly connected to the TT303 terminal block. Check if the sensor signal is reaching the TT303 terminal block by measuring it with a multimeter at the transmitter- end. For mV and thermocouples test can be done with connected and disconnected to the transmitter.
	<ul style="list-style-type: none"> ▪ Noise, Oscillation Adjust damping Check grounding of the transmitters housing, extra important for mV and thermocouple input. Check the terminal block for moisture. Check that the shielding of the wires between sensor/transmitter and transmitter/panel is grounded only in one end.
	<ul style="list-style-type: none"> ▪ Sensor Check the sensor operation; it shall be within its characteristics. Check sensor type; it shall be the type and standard that the TT303 has been configured to. Check if process is within the range of the sensor and the TT303.
INCORRECT READING	<ul style="list-style-type: none"> ▪ Electronic Circuit Failure Check the integrity of circuit replacing it with a spare one.
	<ul style="list-style-type: none"> ▪ Transmitter Configuration Check if the sensor and wires configuration are correct.

Table 4.1 - Messages of Errors and Potential Cause

Disassembly Procedure

Refer to Figure 4.2. Make sure to disconnect the power supply before disassembling the transmitter.

Sensor

If the sensor is mounted on the transmitter, first disconnect the wires in order to prevent the wires from breaking. To access the terminal block, first loosen the cover locking screw on the side marked "Field Terminals", then unscrew the cover.

Electronic Circuits

The main board (5) and input board (7) are matched pairs and must be changed together and not mixed with others. To remove the circuit boards (5 and 7) and display (4), first loosen the cover locking (8) on the side not marked "Field Terminals" then unscrew the cover (1).

Loosen the two screws (3) that anchors the display and the main circuit board. Gently pull out the display, and then the main board (5). To remove the input board (7), first unscrew the two screws (6) that anchors it to the housing (9), gently pull out the board.

WARNING

The boards have CMOS components, which may be damaged by electrostatic discharges. Observe correct procedures for handling CMOS components. It is also recommended to store the circuit boards in electrostatic-proof cases.

Reassemble Procedure

- Put input board (7) into housing (9).
- Anchor input board with its screws (6).
- Put main board (5) into the housing, ensuring all inter connecting pins are connected.
- Put display (4) into the housing, observing the four mounting positions (See *Figure 4.1 - Four Possible Positions of the Display*) " " should point in the direction desired as UP.
- Anchor main board and display with their screws (3).
- Fit the cover (1) and lock it using the locking screw (8).

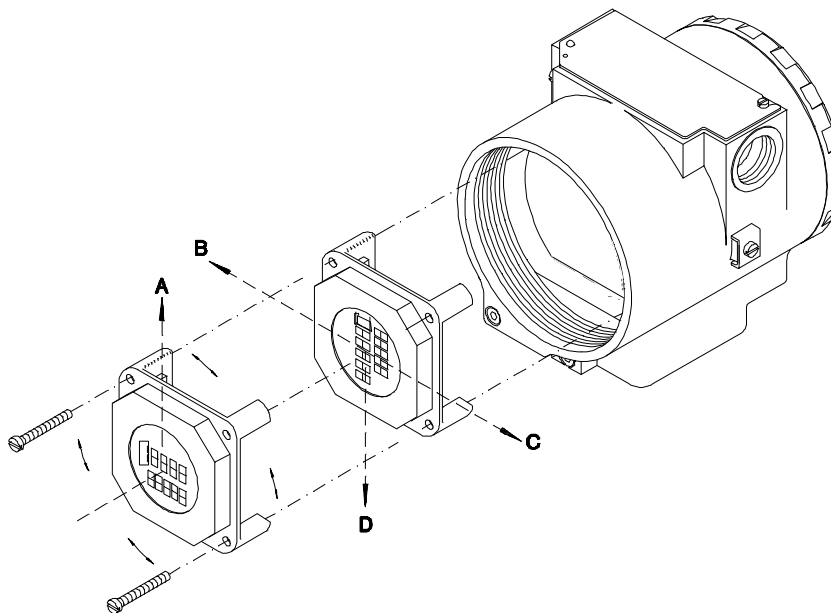

Figure 4.1 - Four Possible Positions of the Display

Interchangeability

The Main and Input boards must be kept together because of the calibration data that is stored in the main board EEPROM. In the case of one board being faulty, both must be replaced.

Returning Materials

Should it become necessary to return the transmitter to **SMAR**, simply contact your local agent or **SMAR** office, informing the defective instrument's serial number, and return it to our factory.

In order to expedite analysis and solution of the problem, the defective item should be returned with a description of the failure observed, with as many details as possible. Other information concerning the instruments operation, such as service and process conditions are also helpful.

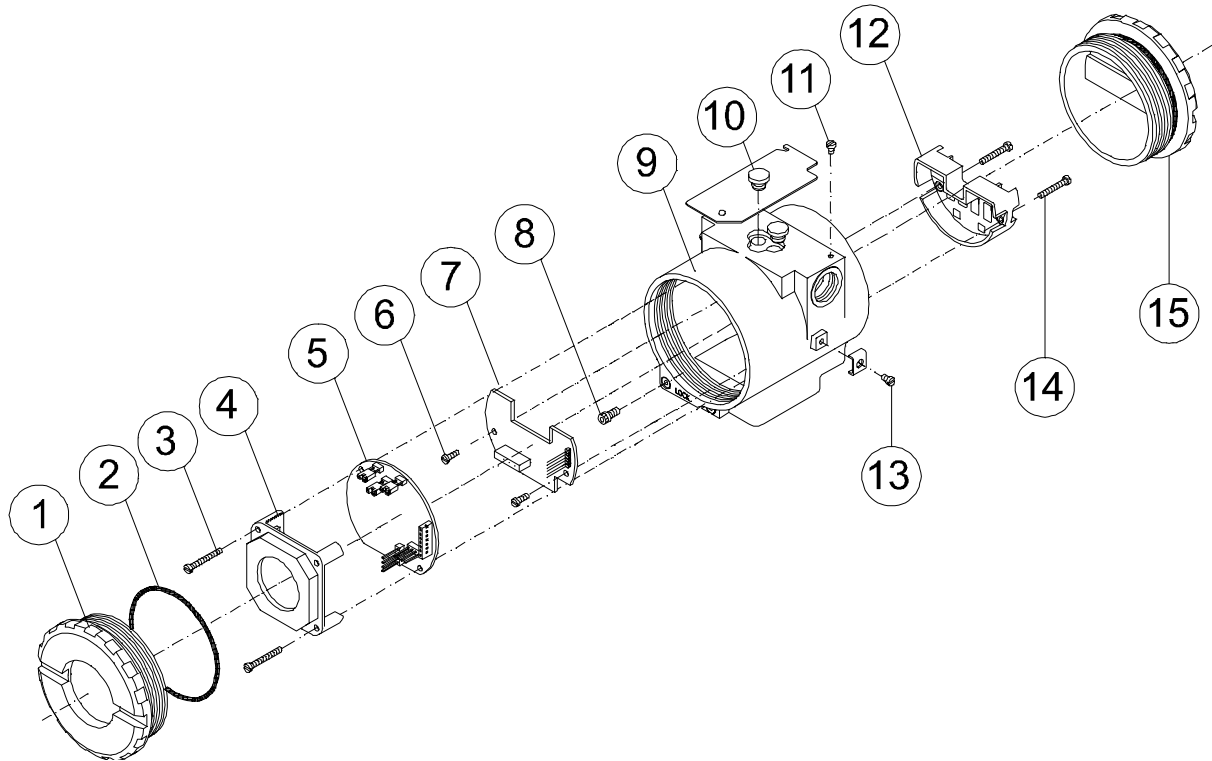

Figure 4.2 - Exploded View

NOTE

For aluminium housing there is an insert in the position 13. This insert is used to improve the grounding.

ACCESSORIES	
ORDERING CODE	DESCRIPTION
SD1	Magnetic Tool for Local Adjustment
PS302	Power Supply
BT302	Terminator
FDI302	Field Device Interface
DF47	Intrinsic Safety Barrier
DF48	Fieldbus Repeater

Table 4.2 - Accessories

SPARE PARTS LIST			
DESCRIPTION OF PARTS	POSITION	CODE	CATEGORY (NOTE 1)
HOUSING, Aluminum (NOTE 2)			
. ½ - 14 NPT	9	400-0298	
. M20 x 1.5	9	400-0299	
. PG 13.5 DIN	9	400-0300	
HOUSING, 316 SS (NOTE 2)			
. ½ - 14 NPT	9	400-0301	
. M20 x 1.5	9	400-0302	
. PG 13.5 DIN	9	400-0303	
COVER (INCLUDES O’RING)			
. Aluminum	1 and 15	204-0102	
. 316 SS	1 and 15	204-0105	
COVER WITH WINDOW FOR INDICATION (INCLUDES O’RING)			
. Aluminum	1	204-0103	
. 316 SS	1	204-0106	
COVER LOCKING SCREW	8	204-0120	
EXTERNAL GROUND SCREW	13	204-0124	
IDENTIFICATION PLATE FIXING SCREW	11	204-0116	
DIGITAL INDICATOR	4	214-0108	
TERMINAL INSULATOR	12	314-0123	
MAIN INPUT CIRCUIT BOARD ASSEMBLY	5 and 7	400-0304	A
O’RINGS (NOTE 3)			
. Cover, Buna-N	2	204-0122	B
TERMINAL HOLDING SCREW.			
. Housing in Aluminum	14	304-0119	
. Housing in 316 Stainless Steel	14	204-0119	
MAIN BOARD SCREW HOUSING IN ALUMINUM			
. Units with indicator	3	304-0118	
. Units without indicator	3	304-0117	
MAIN BOARD SCREW HOUSING IN 316 STAINLESS STEEL			
. Units with indicator	3	204-0118	
. Units without indicator	3	204-0117	
INPUT BOARD SCREW			
. Housing in Aluminum	6	314-0125	
. Housing in 316 Stainless Steel	6	214-0125	
MOUNTING BRACKET FOR 2” PIPE MOUNTING (NOTE 4)			
. Carbon Steel	-	214-0801	
. Stainless Steel 316	-	214-0802	
. Carbon Steel bolts, nuts, washers and U-clamp in Stainless Steel	-	214-0803	
LOCAL ADJUSTMENT PROTECTION CAP	10	204-0114	

Table 4.3 - Spare Part List

NOTE

1. For category A, it is recommended keep, in stock, 25 parts installed for each set, and for category B, 50.
2. It includes Terminal holder insulator, bolts (cover lock, grounding and terminal holder insulator) and identification plate without certification.
3. O-Rings are packaged in packs of 12 units. Including U-clamp, nuts, bolts and washers.

Section 5

TECHNICAL CHARACTERISTIC

Functional Specifications	
Inputs	See table 5.1, 5.2, 5.3 and 5.4
Output and Communication Protocol	Digital only. Complies with IEC 61158-2: 2000 (H1): 31.25 kbit/s voltage mode, bus powered.
Power Supply / Current Consumption	Bus powered: 9 - 32 Vdc. Quiescent current consumption: 12 mA.
Indicator	4 1/2 -digit numerical and 5-character alphanumeric LCD indicator (optional).
Hazardous Area Certifications	Intrinsic Safety (FM, CSA, NEMKO, EXAM, CEPEL, NEPSI), Explosion Proof (FM, CSA, NEMKO, CEPEL), Dust Ignition Proof (FM), Non-incendive (FM), FISCO (FM, CSA, NEMKO, EXAM, CEPEL, NEPSI) and FNICO (FM, CSA, NEMKO, EXAM, CEPEL)
European Directive Information	Authorized representative in European Community Smar GmbH-Rheingaustrasse 9-55545 Bad Kreuznach ATEX Directive (94/9/EC) – Equipment and protective systems intended for use in potentially explosive atmospheres This product was certified according European Standards at NEMKO and EXAM (former DMT). The certified body for manufacturing quality assessment is EXAM (number 0158). LVD Directive 2006/95/EC – Electrical Equipment designed for use within certain voltage limits According the LVD directive Annex II the equipment under ATEX “Electrical equipment for use in an explosive atmosphere” directive are excluded from scope from this directive.
Zero and Span Adjustments	No interactive, via digital communication.
Failure Alarm (Diagnostics)	For sensor or circuit failures, status is sent to output parameters. Detailed diagnostics are available in the contained parameters.
Temperature Limits	Ambient: -40 °C to 85 °C (-40 °F to 185 °F) Storage: -40 °C to 120 °C (-40 °F to 248 °F) Display: -20 °C to 80 °C (-4 °F to 176 °F) -40 °C to 85 °C (-40 °F to 185 °F) (Without damage)
Turn-on Time	Performs within specifications in less than 10 seconds after power is applied to the transmitter.
Configuration	Basic configuration may be done using the local adjustment magnetic tool if device is fitted with display. Complete configuration is possible using configuration tools such as Syscon302 (System Configuration Tool), AMS™, FieldCare™ and HHT375. TT303 can be configured using Profibus View or Simatic PDM.
Humidity Limits	0 to 100% RH
Damping Adjustment	User configurable from 0 to 32 seconds (via digital communication).

Performance Specifications	
Accuracy	See tables 1, 2 and 3
Temperature Effect	For a 10 °C variation: mV (-6 to 22 mV), TC (NBS: B, R, S,T): ± 0.03% of the input millivoltage or 0.002 mV whichever is greater; mV (-10 to 100 mV), TC (NBS: E, J, K, N; DIN: L, U): ± 0.03% of the input millivoltage or 0.01 mV whichever is greater; mV (-50 to 500 mV): ± 0.03% of the input millivoltage or 0.05 mV whichever is greater; Ohms (0 to 100Ω), RTD (GE: Cu10): ± 0.03% of the input resistance or 0.01Ω whichever is greater; Ohms (0 to 400Ω), RTD (DIN: Ni120; IEC: Pt50, Pt100; JIS: Pt50, Pt100): ± 0.03% of the input resistance or 0.04Ω whichever is greater; Ohms (0 to 2000Ω), RTD (IEC: Pt500): ± 0.03% of the input resistance or 0.2Ω whichever is greater; TC: cold-junction compensation rejection 60:1 (Reference: 25.0 ± 0.3 °C).
Power Supply Effect	± 0.005% of calibrated span per volt
Electrical Connection	1/2 - 14 NPT M20 X 1.5 PG 13.5 DIN 1/2 - 14 NPT X 3/4 NPT (AI 316) - with adapter 1/2 - 14 NPT X 3/4 BSP (AI 316) - with adapter 1/2 - 14 NPT X 1/2 BSP (AI 316) - with adapter Note: Explosion proof approvals do not apply to adapter, only to transmitter.
Mounting	Can be attached directly to the sensor. With an optional bracket can be installed on a 2" pipe or fixed on a wall or panel.

Physical Specifications	
Approximate Weights	Sem display e braçadeira de montagem: 0,80 kg Somar para o display: 0,13 kg Somar para a braçadeira de montagem: 0,60 kg

Physical Specifications	
Control Functions Characteristics (Optional)	PHY, TRD, DSP e AI

SENSOR	2, 3 or 4 wires				
	TYPE	RANGE °C	RANGE °F	MINIMUM SPAN °C	°C DIGITAL ACCURACY*
RTD	Cu10 GE	-20 to 250	-4 to 482	50	± 1.0
	Ni120 DIN	-50 to 270	-58 to 518	5	± 0.1
	Pt50 IEC	-200 to 850	-328 to 1562	10	± 0.25
	Pt100 IEC	-200 to 850	-328 to 1562	10	± 0.2
	Pt500 IEC	-200 to 450	-328 to 842	10	± 0.2
	Pt1000 IEC	-200 to 300	-328 to 572	10	± 0.2
	Pt50 JIS	-200 to 600	-328 to 1112	10	± 0.25
	Pt100 JIS	-200 to 600	-328 to 1112	10	± 0.25
THERMOCOUPLE	B NBS	100 to 1800	212 to 3272	50	± 0.5**
	E NBS	-100 to 1000	-148 to 1832	20	± 0.2
	J NBS	-150 to 750	-238 to 1382	30	± 0.3
	K NBS	-200 to 1350	-328 to 2462	60	± 0.6
	N NBS	-100 to 1300	-148 to 2372	50	± 0.5
	R NBS	0 to 1750	32 to 3182	40	± 0.4
	S NBS	0 to 1750	32 to 3182	40	± 0.4
	T NBS	-200 to 400	-328 to 752	15	± 0.15
	L DIN	-200 to 900	-328 to 1652	35	± 0.35
U DIN	-200 to 600	-328 to 1112	50	± 0.5	

Table 5.1 - 2, 3 or 4 wires Sensor Characteristics

* Accuracy of value read on display and accessed by communication. The 4-20 mA accuracy is the digital accuracy ±0.03%
 ** Not applicable for the first 20% of the range (up to 440 °C).

SENSOR	DIFFERENTIAL									
	TYPE		RANGE °C		RANGE °F		MINIMUM SPAN °C	°C DIGITAL ACCURACY*		
RTD	Cu10	GE	-270	to	270	-486	to	486	50	± 2.0
	Ni120	DIN	-320	to	320	-576	to	576	5	± 0.5
	Pt50	IEC	-1050	to	1050	-1890	to	1890	10	± 1.0
	Pt100	IEC	-1050	to	1050	-1890	to	1890	10	± 1.0
	Pt500	IEC	NA		NA		NA	NA	NA	NA
	Pt1000	IEC	NA		NA		NA	NA	NA	NA
	Pt50	JIS	-800	to	800	-1440	to	1440	10	± 1.0
	Pt100	JIS	-800	to	800	-1440	to	1440	10	± 1.5
THERMOCOUPLE	B	NBS	-1700	to	1700	-3060	to	3060	60	± 1.0**
	E	NBS	-1100	to	1100	-1980	to	1980	20	± 1.0
	J	NBS	-900	to	900	-1620	to	1620	30	± 0.6
	K	NBS	-1550	to	1550	-2790	to	2790	60	± 1.2
	N	NBS	-1400	to	1400	-2520	to	2520	50	± 1.0
	R	NBS	-1750	to	1750	-3150	to	3150	40	± 2.0
	S	NBS	-1750	to	1750	-3150	to	3150	40	± 2.0
	T	NBS	-600	to	600	-1080	to	1080	15	± 0.8
	L	DIN	-1100	to	1100	-1980	to	1980	35	± 0.7
U	DIN	-800	to	800	-1440	to	1440	50	± 2.5	

Table 5.2 - Differential Sensor Characteristics

* Accuracy of value read on display and accessed by communication.

** Not applicable for the first 20% of the range (up to 440 °C).

SENSOR	RANGE mV	MINIMUM SPAN mV	*DIGITAL ACCURACY %
mV	-6 to 22	0.40	± 0.02% or ± 2 µV
	-10 to 100	2.00	± 0.02% or ± 10 µV
	-50 to 500	10.00	± 0.02% or ± 50 µV
mV DIF.	-28 to 28	0.40	± 0.10% or ± 10 µV
	-110 to 110	2.00	± 0.10% or ± 50 µV

Table 5.3 - mV Sensor Characteristics

SENSOR	RANGE Ohm	MINIMUM SPAN Ohm	*DIGITAL ACCURACY %
Ohm	0 or 100	1	± 0.02% or ± 0.01 Ohm
	0 or 400	4	± 0.02% or ± 0.04 Ohm
	0 or 2000	20	± 0.02% or ± 0.20 Ohm
Ohm DIF.	-100 or 100	1	± 0.08% or ± 0.04 Ohm
	-400 or 400	4	± 0.1% or ± 0.20 Ohm

Table 5.4 - Ohm Sensor Characteristics

* Accuracy of value read on display and accessed by communication. The 4-20 mA accuracy is the digital accuracy ±0.03%

** Not applicable for the first 20% of the range (up to 440 °C).

NA Not applicable.

Ordering Code

MODEL										TEMPERATURE TRANSMITTER									
COD.		Local Indicator																	
0		Without Indicator								1		With Digital Indicator							
COD.		Mounting Bracket																	
0		Without Bracket		2		316 SST Bracket		A		Flat, 304 SST bracket and 316 SST accessories									
1		Carbon Steel Bracket		7		Carbon Steel Bracket with 316 SST Fasteners													
COD.		Electrical Connections																	
0		1/2 - 14 NPT (3)		3		1/2 - 14 NPT X 1/2 BSP (316 SST) - With adapter (2)		Z		According to user's notes									
1		1/2 - 14 NPT X 3/4 NPT (316 SST) - With adapter (4)		A		M20 x 1.5 (5)													
2		1/2 - 14 NPT X 3/4 BSP (316 SST) - With adapter (2)		B		Pg 13.5 DIN (6)													
COD.		Housing Material (8) (9)																	
H0		Aluminum (IP/TYPE)		H3		316 SST for saline atmosphere (IPW/TYPEX) (10)													
H1		316 SST (IP/TYPE)		H4		Copper Free Aluminum for saline atmosphere (IPW/TYPEX) (10)													
H2		Aluminum for saline atmosphere (IPW/TYPEX) (10)																	
COD.		Identification Plate																	
I1		FM: XP, IS, NI, DI		I4		EXAM (DMT): Ex-ia; NEMKO: Ex-d		I6		Without Certification		IE		NEPSI: Ex-ia					
I3		CSA: XP, IS, NI, DI		I5		CEPEL: Ex-d, Ex-ia		I7		EXAM (DMT): Group I, M1 Ex-ia									
COD.		Tag Plate (7)																	
J0		With tag, when specified (Default)								J2		According to user's notes							
J1		Blank																	
COD.		Sensor Connection																	
L2		2-wire		LF		Differential													
L3		3-wire		LD		Double 2-wire													
L4		4-wire		LB		Backup													
COD.		Painting																	
P0		Gray Munsell N 6,5 Polyester (Default)		P5		Yellow Polyester		PC		Safety Blue Polyester - Electrostatic Painting									
P3		Black Polyester		P8		Without Painting													
P4		White Epoxy		P9		Safety Blue Epoxy – Electrostatic Painting													
COD.		Sensor Type																	
T1		Cu10 - GE		TA		Thermocouple type B - NBS		TP		Thermocouple type U - DIN									
T2		Ni120 - DIN		TB		Thermocouple type E - NBS		TN		100 OHM									
T3		PT50 - IEC		TC		Thermocouple type J - NBS		TO		Special OHM									
T4		PT100 - IEC		TD		Thermocouple type K - NBS		TQ		22 mV									
T5		PT500 - IEC		TE		Thermocouple type N - NBS		TR		100 mV									
T6		PT50 - JIS		TF		Thermocouple type R - NBS		TS		500 mV									
T7		PT100 - JIS		TG		Thermocouple type S - NBS		TT		Special Mv									
T8		2K OHM		TH		Thermocouple type T - NBS		TU		RTD PT1000 – IEC									
T9		400 OHM		TK		Thermocouple type L - DIN													
TT303	1	2	0	H1	I1	JO	L2	P8	T1										

NOTE

- (1) Values limited to 4 1/2 digits; units limited to 5 characters.
- (2) Explosion proof approvals do not apply to adapter, only to transmitter.
- (3) Certified for use in hazardous locations (CEPEL, CSA, FM, NEPSI, NEMKO, EXAM).
- (4) Certified for use in hazardous locations (CEPEL, CSA, FM).
- (5) Certified for use in hazardous locations (CEPEL, FM, NEPSI, NEMKO, EXAM).
- (6) Certified for use in hazardous locations (CEPEL, NEPSI, NEMKO, EXAM).
- (7) Rectangular plate in 316 SST.
- (8) IPX8 tested in 10 meters of water column for 24 hours.
- (9) Ingress Protection:

Product	CEPEL	NEMKO / EXAM	FM	CSA	NEPSI
TT300	IP66/68W	IP66/68W	Type 4X/6(6P)	Type 4X	IP67

- (10) IPW/TYPE testes for 200 hours according to NBR 8094 / ASTM B 117 standard.

CERTIFICATIONS INFORMATION

European Directive Information

Consult www.Smar.com for the EC declarations of conformity and certificates.

Authorized representative/importer located within the Community:

Smar Europe BV De Oude Wereld 116 2408 TM Alphen aan den Rijn Netherlands

ATEX Directive 2014/34/EU - "Equipment for explosive atmospheres" (applicable from 20 April 2016)

The EC-Type Examination Certificate is released by DNV GL Presafe AS (CE2460) and DEKRA EXAM GmbH (CE0158).

Designated certification body that monitors manufacturing and released QAN (Quality Assurance Notification) and QAR (Quality Assessment Report) is Nemko AS (CE0470).

LVD Directive 2014/35/EU – "Low Voltage" (applicable from 20 April 2016)

According to the LVD directive Annex II, electrical equipment for use in an explosive atmosphere is outside the scope of this directive.

According to IEC standard: IEC 61010-1:2010 - Safety requirements for electrical equipment for measurement, control, and laboratory use - Part 1: General requirements.

ROHS Directive 2011/65/EU - "Restriction of the use of certain hazardous substances in electrical and electronic equipment"

For the evaluation of the products the following standards were consulted: EN 50581:2012

EMC Directive 2014/30/EU - "Electromagnetic Compatibility" (applicable from 20 April 2016)

For products evaluation the standard IEC 61326-1:2013 were consulted and to comply with the EMC directive the installation must follow these special conditions:

Use shielded, twisted-pair cable for powering the instrument and signal wiring.

Keep the shield insulated at the instrument side, connecting the other one to the ground.

Hazardous locations general information

Ex Standards:

IEC 60079-0 General Requirements

IEC 60079-1 Flameproof Enclosures "d"

IEC 60079-7 Increased Safe "e"

IEC 60079-11 Intrinsic Safety "i"

IEC 60079-18 Encapsulation "m"

IEC 60079-26 Equipment with equipment protection level (EPL) Ga

IEC 60079-31 Equipment dust ignition protection by enclosure "t"

IEC 60529 Classification of degrees of protection provided by enclosures (IP Code)

IEC 60079-10 Classification of Hazardous Areas

IEC 60079-14 Electrical installation design, selection and erection

IEC 60079-17 Electrical Installations, Inspections and Maintenance

IEC 60079-19 Equipment repair, overhaul and reclamation

ISO/IEC80079-34 Application of quality systems for equipment manufacture

Warning:

Explosions could result in death or serious injury, besides financial damage.

Installation of this instrument in hazardous areas must be in accordance with the local standards and type of protection. Before proceedings with installation make sure that the certificate parameters are in accordance with the classified hazardous area.

Maintenance and Repair

The instrument modification or replaced parts supplied by any other supplier than authorized representative of Smar is prohibited and will void the Certification.

Marking Label

The instrument is marked with type of protection options. The certification is valid only when the type of protection is indicated by the user. Once a particular type of protection is installed, do not reinstall it using any other type of protection.

Intrinsic Safety / Non Incendive application

In hazardous areas with intrinsic safety or or non-incendive requirements, the circuit entity parameters and applicable installation procedures must be observed.

The instrument must be connected to a proper intrinsic safety barrier. Check the intrinsically safe parameters involving the barrier and equipment including the cable and connections. Associated apparatus ground bus shall be insulated from panels and mounting enclosures. Shield is optional, when using shielded cable, be sure to insulate the end not grounded.

Cable capacitance and inductance plus Ci and Li must be smaller than Co and Lo of the Associated Apparatus.

It is recommended do not remove the housing covers when powered on.

Explosionproof / Flameproof application

Only use Explosionproof/Flameproof certified Plugs, Adapters and Cable glands.

The electrical connections entries must be connected using a conduit with sealed unit or closed using metal cable gland or metal blanking plug with at least IP66.

Do not remove the housing covers when powered on.

Enclosure

The electronic housing and sensor threads installed in hazardous areas must have a minimum of 6 fully engaged threads.

The covers must be tightening with at least 8 turns, to avoid the penetration of humidity or corrosive gases, and until it touches the housing. Then, tighten more 1/3 turn (120°) to guarantee the sealing.

Lock the housing and covers using the locking screw.

Degree of Protection of enclosure (IP)

IPx8: Second numeral meaning continuous immersion in water under special condition defined as 10m for a period of 24 hours (Ref: IEC60529).

IPW/ TypeX: Supplementary letter W or X meaning special condition defined as saline environment tested in saturated solution of NaCl 5% w/w at 35°C for a period of 200 hours (Ref: NEMA 250/ IEC60529).

For enclosure with IP/IPW/TypeX applications, all NPT threads must apply a proper water-proof sealant (a non-hardening silicone group sealant is recommended).

Hazardous Locations Approvals

FM Approvals (Factory Mutual)

Intrinsic Safety (FM 3006959)

IS Class I, Division 1, Groups A, B, C and D

IS Class II, Division 1, Groups E, F and G

IS Class III, Division 1

Explosion Proof (FM 3006959)

XP Class I, Division 1, Groups A, B, C and D

Dust Ignition Proof (FM 4Y3A4.AX)

DIP Class II, Division 1, Groups E, F and G

DIP Class III, Division 1

Non Incendive (FM 3006959)

NI Class I, Division 2, Groups A, B, C and D

Environmental Protection (FM 3006959)

Option: Type 4X/6/6P or Type 4/6/6P

Entity Parameters Fieldbus Power Supply Input (report 3015629):

Vmax = 24 Vdc, I_{max} = 250 mA, P_i = 1.2 W, C_i = 5 nF, L_i = 12 uH

Vmax = 16 Vdc, I_{max} = 250 mA, P_i = 2 W, C_i = 5 nF, L_i = 12 uH

Temperature Class: T4

Ambient Temperature: 60°C (-20 to 60 °C)

Drawing

102A-0079, 102A-1233, 102A-1356, 102A-1648, 102A-1649

DNV GL Presafe AS

Explosion Proof (PRESAFE 20 75160X)
 Group II, Category 2 G, Ex db, Group IIC, Temperature Class T6, EPL Gb
 Ambient Temperature: -20 °C to +60 °C
 Options: IP66W/68W or IP66/68

Special conditions for safe use:

Repairs of the flameproof joints must be made in compliance with the structural specifications provided by the manufacturer.

Repairs must not be made on the basis of values specified in tables 1 and 2 of EN/IEC 60079-1.

The Essential Health and Safety Requirements are assured by compliance with:

EN IEC 60079-0:2018 General Requirements

EN 60079-1:2014 Flameproof Enclosures "d"

Drawing

102A-1532, 102A-1476

DEKRA Testing and Certification GmbH

Intrinsic Safety (DMT 00ATEX E 061)

Group I, Category M2, Ex ia, Group I, EPL Mb

Group II, Category 2 G, Ex ia, Group IIC, Temperature Class T4/T5/T6, EPL Gb

Supply circuit for the connection to an intrinsically safe FISCO fieldbus-circuit:

U_i = 24 Vdc, I_i = 380 mA, P_i = 5.32 W, C_i ≤ 5 nF, L_i = Neg

Parameters of the supply circuit comply with FISCO model according to Annex G EN60079-11:2012, replacing EN 60079-27:2008.

2 wire/3 wire/4 wire measuring circuit in type of protection Ex ia I / II C for the connection to intrinsically safe thermocouples or resistance temperature indicators:

U_o = 6.5 Vdc, I_o = 20 mA, P_o = 30 mW, C_i ≤ 300 nF, L_i = Neg, C_o ≤ 700 nF, L_i ≤ 20 mH

The 2 wire/3 wire/4 wire measuring circuit is galvanically separated from the fieldbus circuit.

Ambient Temperature:

-40°C ≤ T_a ≤ +60°C (T4)

-40°C ≤ T_a ≤ +50°C (T5)

-40°C ≤ T_a ≤ +40°C (T6)

The Essential Health and Safety Requirements are assured by compliance with:

EN 60079-0:2012 + A11:2013 General Requirements



EN 60079-11:2012 Intrinsic Safety "i"

Drawing

102A-1476, 102A-1532, 102A-1478, 102A-1534

CEPEL (Centro de Pesquisa de Energia Elétrica)

Segurança Intrínseca (CEPEL 96.0076X)

 <p>CEPEL 96.0076X Equipamento de campo FISCO Ex ia IIC T* Ga</p>					 <p>CEPEL 95.0076X Equipamento de campo FISCO Ex ia IIC T* Da</p>				
IP66W/IP68W			IP66/IP68		IP66W/IP68W			IP66/IP68	
(aço inox e alumínio Copper Free)			(alumínio)		(aço inox e alumínio Copper Free)			(alumínio)	
U _i = 30 V	I _i = 380 mA	P _i = 5,32 W	C _i = 5,0 nF	L _i = desp	U _i = 30 V	I _i = 380 mA	P _i = 5,32 W	C _i = 5,0 nF	L _i = desp
T _{amb} : -20 °C a +50 °C para T5 T _{amb} : -20 °C a +65 °C para T4					T _{amb} : -20 °C a +50 °C para T100 °C T _{amb} : -20 °C a +65 °C para T135 °C				

Prova de Explosão (CEPEL 97.0089)

 <p>CEPEL 97.0089 Ex db IIC T6 Gb Ex tb IIIC T85 °C Db</p>	
IP66W/IP68W	IP66/IP68
(aço inox e alumínio Copper Free)	(alumínio)
T _{amb} : -20 °C a +40 °C	

Observações:

- O número do certificado é finalizado pela letra "X" para indicar que para a versão do Transmissor de temperatura, intrinsecamente seguro, modelo TT303 equipado com invólucro fabricado em liga de alumínio, somente pode ser instalado em "Zona 0", se durante a instalação for excluído o risco de ocorrer impacto ou fricção entre o invólucro e peças de ferro/aço.
- O produto adicionalmente marcado com a letra suplementar "W" indica que o equipamento foi ensaiado em uma solução saturada a 5% de NaCl p/p, à 35 °C, pelo tempo de 200 h e foi aprovado para uso em atmosferas salinas, condicionado à utilização de acessórios de instalação no mesmo material do equipamento e de bujões de aço inoxidável ASTM-A240, para fechamento das entradas roscadas não utilizadas. Os materiais de fabricação dos equipamentos aprovados para letra "W" são: aço inoxidável AISI 316 e alumínio Copper Free SAE 336 pintados (Procedimento P-CQ-FAB764-09) com tinta Resina Poliéster ou Resina Epoxy com espessura da camada de tinta de 70 a 150 µm e 120 a 200 µm, respectivamente, ou pintados com o plano de pintura P1 e P2 (Procedimento P-CQ-FAB-765-05) com tinta Resina Epoxy ou Poliuretano Acrílico Alifático com espessura de camada de tinta de 290 µm a 405 µm e 185 µm a 258 µm, respectivamente.
- Os planos de pintura P1 e P2 são permitidos apenas para equipamento fornecido com plaqueta de identificação com marcação para grupo de gases IIB.
- O grau de proteção IP68 só é garantido se nas entradas roscadas de ½" NPT for utilizado vedante não endurecível à base de silicone conforme Procedimento P-DM-FAB277-06.
- O segundo numeral oito indica que o equipamento foi ensaiado para uma condição de submersão de dez metros por vinte e quatro horas. O acessório deve ser instalado em equipamentos com grau de proteção equivalente.
- As atividades de instalação, inspeção, manutenção, reparo, revisão e recuperação dos equipamentos são de responsabilidade dos usuários e devem ser executadas de acordo com os requisitos das normas técnicas vigentes e com as recomendações do fabricante.

Normas Aplicáveis:

ABNT NBR IEC 60079-0:2013 Atmosferas explosivas - Parte 0: Equipamentos – Requisitos gerais

ABNT NBR IEC 60079-1:2016 Atmosferas explosivas - Parte 1: Proteção de equipamento por invólucro à prova de explosão "d"

ABNT NBR IEC 60079-11:2013 Atmosferas explosivas - Parte 11: Proteção de equipamento por segurança intrínseca "i"

ABNT NBR IEC 60079-26:2016 Equipamentos elétricos para atmosferas explosivas - Parte 26: Equipamentos com nível de proteção de equipamento (EPL) Ga

ABNT NBR IEC 60079-31:2014 Atmosferas explosivas - Parte 31: Proteção de equipamentos contra ignição de poeira por invólucros "t"

ABNT NBR IEC 60529:2017 Graus de proteção para invólucros de equipamentos elétricos (Código IP)

Desenhos

102A1383	TT303 Plaqueta de identificação CEPEL IP66/68
102A1263	TT303 Plaqueta de identificação CEPEL IP66W/68W
102A2054	TT303 Plaqueta de identificação CEPEL IP66/68 IIB P1/P2
102A2053	TT303 Plaqueta de identificação CEPEL IP66W/68W IIB P1/P2
102A2102	TT303 Plaqueta de identificação CEPEL IP66 POEIRA

Identification Plate

FM Approvals (Factory Mutual)

smar TT303 Temperature Transmitter
BR - 14160
Made in Brazil

Temp. Class: T4	XP CL I, DIV 1, GP A,B,C,D.
Tamb. 60°C max.	DIP CL II,III, DIV 1, GP E,F,G.
Vmax. 24 VDC	S CL III, DIV 1.
I max. 250 mA	IS CL I,II,III, DIV 1, GP A,B,C,D,E,F,G.
Ci 5 nF	NI CL I, DIV 2, GP A,B,C,D.
Li 8 uH	Per inst. dwg 102A0079.

FM APPROVED Type 4X/6/6P

0044333 - 2007 PROFIBUS-PA CE 123300

smar TT303 Temperature Transmitter
BR - 14160
Made in Brazil

Temp. Class: T4	XP CL I, DIV 1, GP A,B,C,D.
Tamb. 60°C max.	DIP CL II,III, DIV 1, GP E,F,G.
Vmax. 24 VDC	S CL III, DIV 1.
I max. 250 mA	IS CL I,II,III, DIV 1, GP A,B,C,D,E,F,G.
Ci 5 nF	NI CL I, DIV 2, GP A,B,C,D.
Li 8 uH	Per inst. dwg 102A0079.

FM APPROVED Type 4X/6/6P

0044333 - 2007 PROFIBUS-PA CE 135600

smar TT303 Temperature Transmitter
TX - 77040
Made in USA

Temp. Class: T4	XP CL I, DIV 1, GP A,B,C,D.
Tamb. 60°C max.	DIP CL II,III, DIV 1, GP E,F,G.
Vmax. 24 VDC	S CL III, DIV 1.
I max. 250 mA	IS CL I,II,III, DIV 1, GP A,B,C,D,E,F,G.
Ci 5 nF	NI CL I, DIV 2, GP A,B,C,D.
Li 8 uH	Per inst. dwg 102A0079.

FM APPROVED Type 4/6/6P

00000 - 0000 PROFIBUS-PA CE 164801

smar TT303 Temperature Transmitter
TX - 77040
Made in USA

Temp. Class: T4	XP CL I, DIV 1, GP A,B,C,D.
Tamb. 60°C max.	DIP CL II,III, DIV 1, GP E,F,G.
Vmax. 24 VDC	S CL III, DIV 1.
I max. 250 mA	IS CL I,II,III, DIV 1, GP A,B,C,D,E,F,G.
Ci 5 nF	NI CL I, DIV 2, GP A,B,C,D.
Li 8 uH	Per inst. dwg 102A0079.

FM APPROVED Type 4X/6/6P

0000000 - 0000 PROFIBUS-PA CE 164901

DNV GL Presafe AS / DEKRA Testing and Certification GmbH

smar TT303 Temperature Transmitter
Nova Smar S/A
Av. Dr. Antônio Furlan Jr
1028 Sertãozinho-SP
14170-480
Brazil

Ex II 2G Ex ia IIC T4/T5/T6 Gb DMT 00 ATEX E 061 ()
Pi = 5,32 W -40°C ≤ Ta ≤ +60°C
Ui = 24 VDC li = 380 mA Li = neg Ci ≤ 5 nF

IP66
IP68 10m/24h

Ex II 2G Ex db IIC T6 Gb PRESAFE 20 ATEX 75160X ()
Tamb = -20°C to 60°C U = 28 VDC

0000000 - 0000 PROFIBUS-PA CE 0470 147605

smar TT303 Temperature Transmitter
Nova Smar S/A
Av. Dr. Antônio Furlan Jr
1028 Sertãozinho-SP
14170-480
Brazil

Ex II 2G Ex ia IIC T4/T5/T6 Gb DMT 00 ATEX E 061 ()
Pi = 5,32 W -40°C ≤ Ta ≤ +60°C
Ui = 24 VDC li = 380 mA Li = neg Ci ≤ 5 nF

IP66W
IP68W 10m/24h

Ex II 2G Ex db IIC T6 Gb PRESAFE 20 ATEX 75160X ()
Tamb = -20°C to 60°C U = 28 VDC

0000000 - 0000 PROFIBUS-PA CE 0470 153205

smar TT303 Temperature Transmitter
BR - 14160
Sertãozinho
Brazil

Ex I M2 Ex ia I Mb DMT 00 ATEX E 061
-40°C ≤ Ta ≤ +60°C
Pi = 5,32 W
Ui = 24 VDC li = 380 mA Li = neg Ci ≤ 5 nF

IP 66 68

0000000 - 0000 PROFIBUS-PA CE 0470 147801

smar TT303 Temperature Transmitter
BR - 14160
Sertãozinho
Brazil

Ex I M2 Ex ia I Mb DMT 00 ATEX E 061
-40°C ≤ Ta ≤ +60°C
Pi = 5,32 W
Ui = 24 VDC li = 380 mA Li = neg Ci ≤ 5 nF

IP 66 W 68 W

0000000 - 0000 PROFIBUS-PA CE 0470 153401

CEPEL (Centro de Pesquisa de Energia Elétrica)

smar TT303 Transmissor de Temperatura
Nova Smar S/A
Av. Dr. Antônio Furlan Jr
1028 Sertãozinho-SP
14170-480
Brazil

FISCO Field Device - Ex ia IIC T4 Ga
FISCO Field Device - Ex ic IIC T4 Gc

Ex db IIC T6 Gb CEPEL 97.0089 ()
Ex ia IIC T4/T5 Ga CEPEL 97.0076 X ()
Tamb = -20° a 65°C (T4) -20° a 50°C (T5)
Ui = 30V li = 380mA Pi = 5,32W
Ci = 5nF Li = desp

Segurança
Eletrabras
INMETRO

IP 66 68

0000000 - 0000 PROFIBUS-PA CE 138303

smar TT303 Transmissor de Temperatura
Nova Smar S/A
Av. Dr. Antônio Furlan Jr
1028 Sertãozinho-SP
14170-480
Brazil

FISCO Field Device - Ex ia IIC T4 Ga
FISCO Field Device - Ex ic IIC T4 Gc

Ex db IIC T6 Gb CEPEL 97.0089 ()
Ex ia IIC T4/T5 Ga CEPEL 97.0076 X ()
Tamb = -20° a 65°C (T4) -20° a 50°C (T5)
Ui = 30V li = 380mA Pi = 5,32W
Ci = 5nF Li = desp

Segurança
Eletrabras
INMETRO

IP 66 W 68 W



0000000 - 0000 PROFIBUS-PA CE 126303

TT303 - Certification Information

smar TT303 Transmissor de Temperatura
 Nova Smar S/A
 Av. Dr. Antônio Furlan Jr
 1028 Sertãozinho-SP
 14170-480
 Brazil

FISCO Field Device - Ex ia IIC T4 Ga
 FISCO Field Device - Ex ic IIC T4 Gc

Ex db IIB T6 Gb CEPEL 97.0089 ()
 Ex ia IIB T4/T5 Ga CEPEL 97.0076 X ()
 Tamb= -20° a 65°C (T4) -20° a 50°C (T5)
 Ui= 30V li= 380mA Pi= 5,32W
 Ci= 5nF Li= desp

Segurança





IP 66 68
P1/P2 Pintura

0000000 - 0000 PROFIBUS-PA  **205401**

smar TT303 Transmissor de Temperatura
 Nova Smar S/A
 Av. Dr. Antônio Furlan Jr
 1028 Sertãozinho-SP
 14170-480
 Brazil

FISCO Field Device - Ex ia IIC T4 Ga
 FISCO Field Device - Ex ic IIC T4 Gc

Ex db IIB T6 Gb CEPEL 97.0089 ()
 Ex ia IIB T4/T5 Ga CEPEL 97.0076 X ()
 Tamb= -20° a 65°C (T4) -20° a 50°C (T5)
 Ui= 30V li= 380mA Pi= 5,32W
 Ci= 5nF Li= desp



Segurança



IP 66W 68W
P1/P2 Pintura

0000000 - 0000 PROFIBUS-PA  **205301**

smar TT303 Transmissor de Temperatura
 Nova Smar S/A
 Av. Dr. Antônio Furlan Jr
 1028 Sertãozinho-SP
 14170-480
 Brazil

Ex tb IIIC T85°C Db CEPEL 97.0089 ()
 Ex ia IIIC T135°C/T100°C Da CEPEL 96.0076 X ()
 Tamb= -20° a 65°C (T135°C)
 -20° a 50°C (T100°C)
 Ui= 30V li= 380mA Pi= 5,32W
 Ci= 5nF Li= desp

Segurança



IP 66 68

0000000 - 0000 PROFIBUS-PA  **210201**

FM Approvals (Factory Mutual)

NON HAZARDOUS OR DIVISION 2 AREA

SAFE AREA APPARATUS

UNSPECIFIED, EXCEPT THAT IT MUST NOT BE SUPPLIED FROM, NOR CONTAIN UNDER NORMAL OR ABNORMAL CONDITIONS, A SOURCE OF POTENTIAL IN RELATION TO EARTH IN EXCESS OF 250VAC OR 250VDC.

ASSOCIATED APPARATUS

OPTIONAL SHIELDING

FIELDBUS BARRIER

GROUND BUS

POWER SUPPLY

HAZARDOUS AREA

REQUIREMENTS:

- 1 - INSTALLATION MUST BE IN ACCORDANCE WITH THE NATIONAL ELECTRICAL CODE (ANSI/NFPA 70) AND ANSI/ISA-RP12.6
- 2 - TRANSMITTER SPECIFICATION MUST BE IN ACCORDANCE TO APPROVAL LISTING.
- 3 - ASSOCIATED APPARATUS GROUND BUS TO BE INSULATED FROM PANELS AND MOUNTING ENCLOSURES.
- 4 - WIRES: TWISTED PAIR, 22AWG OR LARGER.
- 5 - SHIELD IS OPTIONAL IF USED, BE SURE TO INSULATE THE END NOT GROUNDED.
- 6 - CABLE CAPACITANCE AND INDUCTANCE PLUS C_i AND L_i MUST BE SMALLER THAN C_a AND L_a OF THE ASSOCIATED APPARATUS.
- 7 - ONLY SIMPLE APPARATUS CAN BE CONNECTED TO THE SENSOR TERMINALS 1,2,3,4. SIMPLE APPARATUS IS A DEVICE THAT WILL NOT GENERATE OR STORE MORE THAN 1.2V, 0.1A, 25mW, OR 20µJ. EXAMPLES ARE SWITCHES, THERMOCOUPLES AND RESISTANCE TEMPERATURE DETECTORS.

ENTITY PARAMETERS FOR TEMPERATURE SENSOR TERMINALS:

V_t=8.25V I_t=85.3mA C_a=5.5µF L_a=4.8mH

INTRINSICALLY SAFE APPARATUS

ENTITY VALUES: C_i=5nF L_i=8µH

V_{max} ≤ 24V

I_{max} ≤ 250mA

CLASS I,II,III DIV.1, GROUPS A,B,C,D,E,F & G

MODELS TT302 AND TT303 - SERIES

TEMPERATURE TRANSMITTERS.

COMPONENTS CAN NOT BE SUBSTITUTED WITHOUT PREVIOUS MANUFACTURER APPROVAL.

APPROVAL CONTROLLED BY C.A.R.

6	MARCIAL 20/10/08	GRATON 20/10/08	ALT DE 0049/08	DRAWING	DESIGN	VERIFIED	APPROVED
5	MARCIAL 16/07/07	MISSAWA 16/07/07	ALT DE 0004/07	MELONI 24/03/95	M.MISSAWA 24/03/95	SINASTRE 24/03/95	PELUSO 24/03/95
4	MOACIR 05/05/03	CASSIOLATO 05/05/03	ALT DE 0043/03	CUSTOMER:			
3	MOACIR 08/02/00	CASSIOLATO 08/02/00	ALT DE 0015/00	EQUIPMENT: TT302/303			
REV.	DESIGN	APPROVED	AREA	CONTROL DRAWING			

APPROVED

ENTITY PARAMETERS FOR ASSOCIATED APPARATUS

CLASS I,II,III DIV.1

GROUPS A,B,C,D,E,F & G

C_a ≥ CABLE CAPACITANCE +5nF

L_a ≥ CABLE INDUCTANCE +8µH

option 1	V _{oc} ≤ 24V	I _{sc} ≤ 250mA	P _o ≤ 1.2W
option 2	V _{oc} ≤ 16V	I _{sc} ≤ 250mA	P _o ≤ 2W

Appendix B

		SRF-SERVICE REQUEST FORM		Proposal No.:	
Company:		Unit:		Receipt of Remittance:	Warranty
				Yes () Purchase Order:	No ()
COMMERCIAL CONTACT			TECHNICAL CONTACT		
Full name:			Full name:		
Position:			Position:		
Phone:		Extension:	Phone:		Extension:
Fax:			Fax:		
Email:			Email:		
EQUIPMENT DATA / TEMPERATURE SENSOR					
Model: TT301 () TT302 () TT303 () TT400SIS () TT411 () TT421 ()		Serial Number:		Sensor Type and Connection: Measurement type: () Double Sensor () Average between Sensors () Differential () Backup () Single	
INFORMATION AND DESCRIPTION OF THE FAILURE					
Environment Temperature (°C)		Work Temperature (°C)		Calibration Range	
Min:	Max:	Min :	Max:	Min:	Max:
Operation Time:			Failure Data:		
IMPORTANT COMMENTS ABOUT EQUIPMENT APPLICATION AND PROCESS (Please, inform more details about the application, installation, etc.).					
FAILURE DESCRIPTION OR BAD OPERATION (Please, describe the behavior of the fail, if it is repetitive, how it exactly happens, and so on.)					
NOTES					
For warranty or non-warranty repair, please contact your representative. Further information about address and contacts can be found on www.smar.com/contactus.asp .					

SMAR WARRANTY CERTIFICATE

1. SMAR guarantees the equipment of its own manufacture for a period of 24 (twenty four) months, starting on the day the invoice is issued. The guarantee is effective regardless of the day the product was installed. Third-party equipment and software are not included in this Term of Guarantee and Smar does not offer any guarantee or declaration in the name of the manufacturer. Any guarantees related to these products are the supplier or licensor responsibility.
2. SMAR products are guaranteed against any defect originating from manufacturing, mounting, whether of a material or manpower nature, provided that the technical analysis reveals the existence of a quality failure liable to be classified under the meaning of the word, duly verified by the technical team within the warranty terms.
3. Exceptions are proven cases of inappropriate use, wrong handling or lack of basic maintenance compliant to the equipment manual provisions. SMAR does not guarantee any defect or damage caused by an uncontrolled situation, including but not limited to negligence, user imprudence or negligence, natural forces, wars or civil unrest, accidents, inadequate transportation or packaging due to the user's responsibility, defects caused by fire, theft or stray shipment, improper electric voltage or power source connection, electric surges, violations, modifications not described on the instructions manual, and/or if the serial number was altered or removed, substitution of parts, adjustments or repairs carried out by non-authorized personnel; inappropriate product use and/or application that cause corrosion, risks or deformation on the product, damages on parts or components, inadequate cleaning with incompatible chemical products, solvent and abrasive products incompatible with construction materials, chemical or electrolytic influences, parts and components susceptible to decay from regular use, use of equipment beyond operational limits (temperature, humidity, etc.) according to the instructions manual. In addition, this Warranty Certificate excludes expenses with transportation, freight, insurance, all of which are the customer's responsibility.
4. For warranty or non-warranty repair, please contact your representative.

Further information about address and contacts can be found on www.smar.com/contactus.asp

5. In cases needing technical assistance at the customer's facilities during the warranty period, the hours effectively worked will not be billed, although SMAR shall be reimbursed from the service technician's transportation, meals and lodging expenses, as well dismounting/mounting costs, if any.
6. The repair and/or substitution of defective parts do not extend, under any circumstance, the original warranty term, unless this extension is granted and communicated in writing by SMAR.
7. No Collaborator, Representative or any third party has the right, on SMAR's behalf, to grant warranty or assume some responsibility for SMAR products. If any warranty would be granted or assumed without SMAR's written consent, it will be declared void beforehand.
8. Cases of Extended Warranty acquisition must be negotiated with and documented by SMAR.
9. If necessary to return the equipment or product for repair or analysis, contact us.
See item 4.
10. In cases of repair or analysis, the customer must fill out the Revision Requisition Form (FSR) included in the instructions manual, which contains details on the failure observed on the field, the circumstances it occurred, in addition to information on the installation site and process conditions. Equipments and products excluded from the warranty clauses must be approved by the client prior to the service execution.
11. In cases of repairs, the client shall be responsible for the proper product packaging and SMAR will not cover any damage occurred in shipment.

12. In cases of repairs under warranty, recall or outside warranty, the client is responsible for the correct packaging and packing and SMAR shall not cover any damage caused during transportation. Service expenses or any costs related to installing and uninstalling the product are the client's sole responsibility and SMAR does not assume any accountability before the buyer.
13. It is the customer's responsibility to clean and decontaminate products and accessories prior to shipping them for repair, and SMAR and its dealer reserve themselves the right to refuse the service in cases not compliant to those conditions. It is the customer's responsibility to tell SMAR and its dealer when the product was utilized in applications that contaminate the equipment with harmful products during its handling and repair. Any other damages, consequences, indemnity claims, expenses and other costs caused by the lack of decontamination will be attributed to the client. Kindly, fill out the Declaration of Decontamination prior to shipping products to SMAR or its dealers, which can be accessed at www.smar.com/doc/declarationofcontamination.pdf and include in the packaging.
14. This warranty certificate is valid only when accompanying the purchase invoice.