

smar
First in Fieldbus

- TT302

AUG / 20
TT302
VERSION 3



OPERATION & MAINTENANCE
INSTRUCTION MANUAL

FIELDBUS TEMPERATURE TRANSMITTER

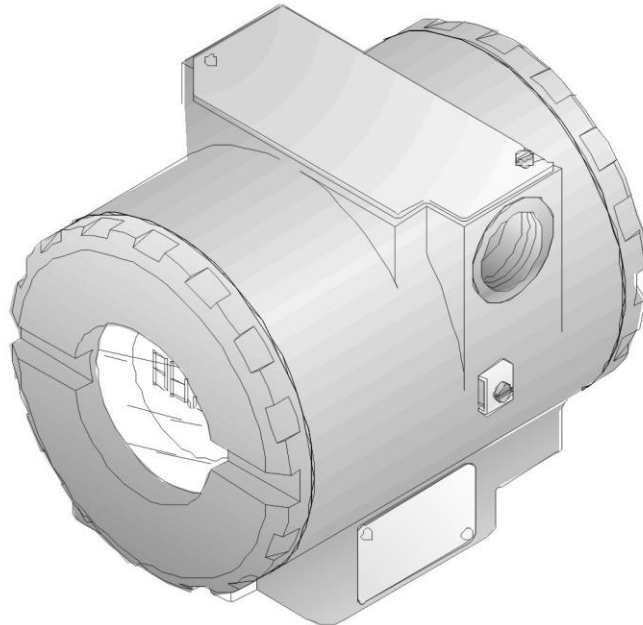

smar
NOVA SMAR S/A
www.smar.com.br

Specificatinos and information are subject to change without notice.
Up-to-date address information is available on our website.

web: www.smar.com/contactus.asp

INTRODUCTION

The **TT302** is from the first generation of FIELDBUS devices. It is a transmitter mainly intended for measurement of temperature using RTDs or thermocouples, but can also accept other sensors with resistance or mV output such as: pyrometers, load cells, resistance position indicators, etc. The digital technology used in the **TT302** enables a single model to accept several types of sensors, an easy interface between the field and the control room and several others features that considerably reduces the installation, operation and maintenance costs.

FIELDBUS is not only a replacement for 4-20 mA or intelligent/smart transmitter protocols. It contains much more. FIELDBUS is a complete system enabling distribution of the control function to equipment in the field.

Some advantages of bi-directional digital communications are known from existing smart transmitter protocols: higher accuracy, multivariable access, remote configuration and diagnostics and multi-dropping of several devices on a single pair of wires. These protocols were not intended to transfer control data, but maintain information. Therefore they were slow and not efficient enough to be used.

The main requirements for Fieldbus were to overcome these problems. Closed loop control with performance like a 4-20 mA system requires higher speed. Since higher speed means higher power consumption, this clashes with the need for intrinsic safety. Therefore a moderately high communication speed was selected, and the system was designed to have minimum communication overhead. Using scheduling, the system controls the variable sampling, the algorithm execution and the communication to optimize the usage of the network, thus achieving high closed loop performance.

Using Fieldbus technology, with its capability to interconnect several devices, very large control schemes can be constructed. In order to be user friendly, the function block concept was introduced (users of SMAR CD600 should be familiar with this, since it was implemented several years ago). The user may now easily build and overview complex control strategies. Another advantage is adding flexibility, the control strategy may be edited without having to rewire or change any hardware.

Now, thanks to Fieldbus, the transmitter accepts two channels, i.e., two measurements. This reduces the cost per channel. Other function blocks are also available. They allow flexibility in control strategy implementation.

The need for Fieldbus implementation in small as well as large systems was considered when developing the entire 302 line of Fieldbus devices. They have the common features of being able to act as a master on the network.

Get the best result of the TT302 by carefully reading these instructions.

WARNING

This Manual is compatible with version 3.XX, where 3 denote software version and XX software release. The indication 3.XX means that this manual is compatible with any release of software version 3.

Waiver of responsibility

The contents of this manual abides by the hardware and software used on the current equipment version. Eventually there may occur divergencies between this manual and the equipment. The information from this document are periodically reviewed and the necessary or identified corrections will be included in the following editions. Suggestions for their improvement are welcome.

Warning

For more objectivity and clarity, this manual does not contain all the detailed information on the product and, in addition, it does not cover every possible mounting, operation or maintenance cases.

Before installing and utilizing the equipment, check if the model of the acquired equipment complies with the technical requirements for the application. This checking is the user's responsibility.

If the user needs more information, or on the event of specific problems not specified or treated in this manual, the information should be sought from Smar. Furthermore, the user recognizes that the contents of this manual by no means modify past or present agreements, confirmation or judicial relationship, in whole or in part.

All of Smar's obligation result from the purchasing agreement signed between the parties, which includes the complete and sole valid warranty term. Contractual clauses related to the warranty are not limited nor extended by virtue of the technical information contained in this manual.

Only qualified personnel are allowed to participate in the activities of mounting, electrical connection, startup and maintenance of the equipment. Qualified personnel are understood to be the persons familiar with the mounting, electrical connection, startup and operation of the equipment or other similar apparatus that are technically fit for their work. Smar provides specific training to instruct and qualify such professionals. However, each country must comply with the local safety procedures, legal provisions and regulations for the mounting and operation of electrical installations, as well as with the laws and regulations on classified areas, such as intrinsic safety, explosion proof, increased safety and instrumented safety systems, among others.

The user is responsible for the incorrect or inadequate handling of equipments run with pneumatic or hydraulic pressure or, still, subject to corrosive, aggressive or combustible products, since their utilization may cause severe bodily harm and/or material damages.

The field equipment referred to in this manual, when acquired for classified or hazardous areas, has its certification void when having its parts replaced or interchanged without functional and approval tests by Smar or any of Smar authorized dealers, which are the competent companies for certifying that the equipment in its entirety meets the applicable standards and regulations. The same is true when converting the equipment of a communication protocol to another. In this case, it is necessary sending the equipment to Smar or any of its authorized dealer. Moreover, the certificates are different and the user is responsible for their correct use.

Always respect the instructions provided in the Manual. Smar is not responsible for any losses and/or damages resulting from the inadequate use of its equipments. It is the user's responsibility to know and apply the safety practices in his country.

TABLE OF CONTENTS

SECTION 1 - INSTALLATION	1.1
GENERAL.....	1.1
MOUNTING	1.1
NETWORK WIRING	1.2
BUS TOPOLOGY AND NETWORK CONFIGURATION	1.4
SENSOR WIRING	1.5
INSTALLATION IN HAZARDOUS AREAS	1.7
EXPLOSION/FLAME PROOF	1.7
INTRINSICALLY SAFE.....	1.7
SECTION 2 - OPERATION	2.1
FUNCTIONAL DESCRIPTION – HARDWARE.....	2.1
TEMPERATURE SENSORS	2.3
SECTION 3 - CONFIGURATION	3.1
TRANSDUCER BLOCK.....	3.1
TRANSDUCER BLOCK PARAMETERS DESCRIPTION.....	3.1
TRANSDUCER BLOCK PARAMETERS TYPES	3.2
HOW TO CONFIGURE A TRANSDUCER BLOCK	3.3
SENSOR TRANSDUCER NUMBER	3.4
JUMPER CONFIGURATION	3.4
SENSOR CONFIGURATION.....	3.4
HOW TO CONNECT TWO SENSORS TO TT302	3.7
COMPENSATION OF LEAD RESISTANCE FOR DOUBLE SENSOR (RTD OR OHM)	3.7
COLD JUNCTION COMPENSATION.....	3.8
CALIBRATION IN TT302 BY THE USER	3.8
CHANGING UNITS IN TEMPERATURE SENSORS.....	3.10
TRANSDUCER DISPLAY – CONFIGURATION.....	3.10
DISPLAY TRANSDUCER BLOCK.....	3.11
DEFINITION OF PARAMETERS AND VALUES	3.11
PROGRAMMING USING LOCAL ADJUSTMENT	3.14
J1 JUMPER CONNECTIONS.....	3.15
W1 JUMPER CONNECTIONS	3.15
LOCAL PROGRAMMING TREE.....	3.16
SECTION 4 - MAINTENANCE PROCEDURES	4.1
TROUBLESHOOTING	4.1
DISASSEMBLY PROCEDURE.....	4.2
REASSEMBLY PROCEDURE.....	4.2
INTERCHANGEABILITY	4.3
RETURNING MATERIALS	4.3
SECTION 5 - TECHNICAL CHARACTERISTIC	5.1
ORDERING CODE	5.4
APPENDIX A - CERTIFICATIONS INFORMATION	A.1
APPENDIX B – SRF – SERVICE REQUEST FORM	B.1

Installation Flowchart

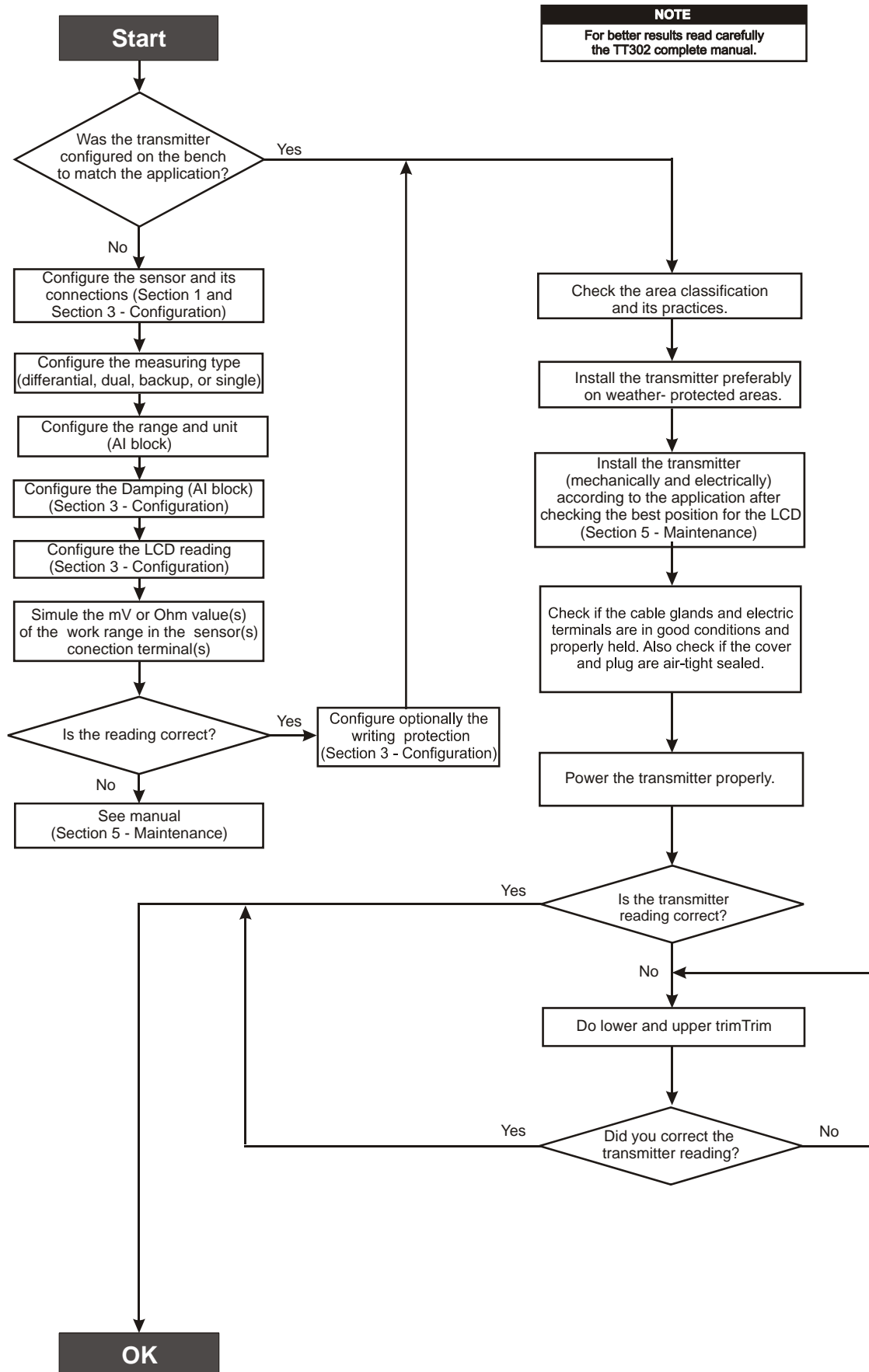

INSTALLATION

General

The overall accuracy of temperature and other measurements depends on several variables. Although the transmitter has an outstanding performance, proper installation is essential in order to maximize its performance.

Among all factors which may affect transmitter accuracy, environmental conditions are the most difficult to control. There are, however, ways of reducing the effects of temperature, humidity and vibration.

Locating the transmitter in areas protected from extreme environmental changes can minimize temperature fluctuation effects.

In warm environments, the transmitter should be installed in such a way as to avoid, as much as possible, direct exposure to the sun. Installation close to lines and vessels subjected to high temperatures should also be avoided. For temperature measurements, sensors with cooling-neck can be used or the sensor can be mounted separately from the transmitter housing.

Use of sunshades or heat shields to protect the transmitter from external heat sources should be considered.

Humidity is fatal for electronic circuits. In areas subjected to high relative humidity, the O-rings for the electronic housing covers must be correctly placed and the covers must be completely closed by tightening them by hand until you feel the O-rings being compressed. Do not use tools to close the covers. Removal of the electronics cover in the field should be reduced to the minimum necessary, since each time it is removed, the circuits are exposed to humidity. The electronic circuit is protected by a humidity proof coating, but frequent exposure to humidity may affect the protection provided. It is also important to keep the covers tightened in place. Every time they are removed, the threads are exposed to corrosion, as painting cannot protect these parts. Code-approved sealing methods should be employed on conduit entering the transmitter.

Connecting the sensor as close to the transmitter as possible and using proper wires (See Section 2 Operation), can decrease measurement error.

Mounting

The transmitter may be mounted in two basic ways:

- Separated from the sensor, using optional mounting brackets.
- Mounted on the sensor assembly.

It can be mounted in several different positions using the bracket, as shown in Figure 1.3 - Dimensional Drawing and Mounting Positions. You can also see in the Figure 1.3 how the conduit inlets for electrical connection are used to mount the sensor integral to the temperature transmitter.

For better visibility, the digital display may be rotated in steps of 90°. (See Figure 4.1 – Four Possible Positions of the Display).

Network Wiring

Access the terminal block by removing the Electrical Connection Cover. This cover can be locked closed by the cover locking screw (See Figure 1.1 - Cover Locking). To release the cover, rotate the locking screw clockwise.

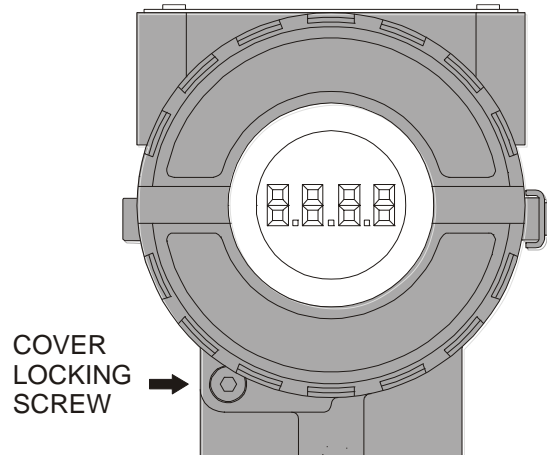

Figure 1.1 - Cover Locking

Cable access to wiring connections are obtained by one of the two conduit outlets. Conduit threads should be sealed by means of code-approved sealing methods. **The unused outlet connection should be plugged accordingly.**

The wiring block has screws on which fork or ring type terminals can be fastened. (See Figure 1.2 - Ground Terminals).

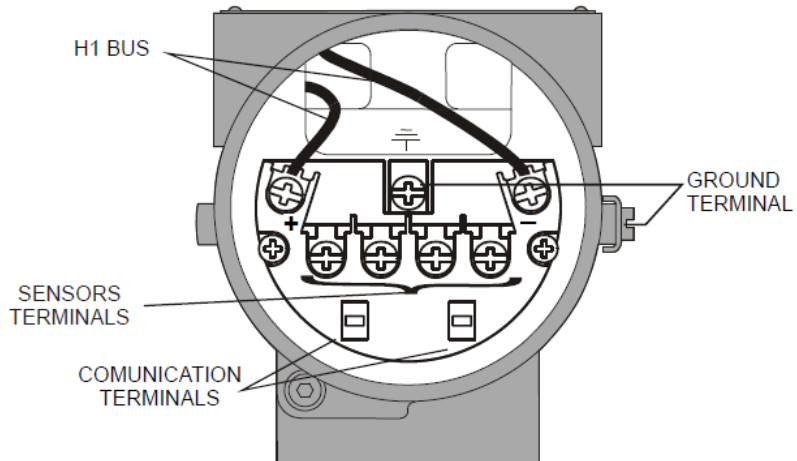

Figure 1.2 - Ground Terminals

For convenience, there are three ground terminals: one inside the cover and two externally, located close to the conduit entries.

WARNING

Do not connect the Fieldbus network wires to the sensor terminals. (Terminals 1, 2, 3 and 4).

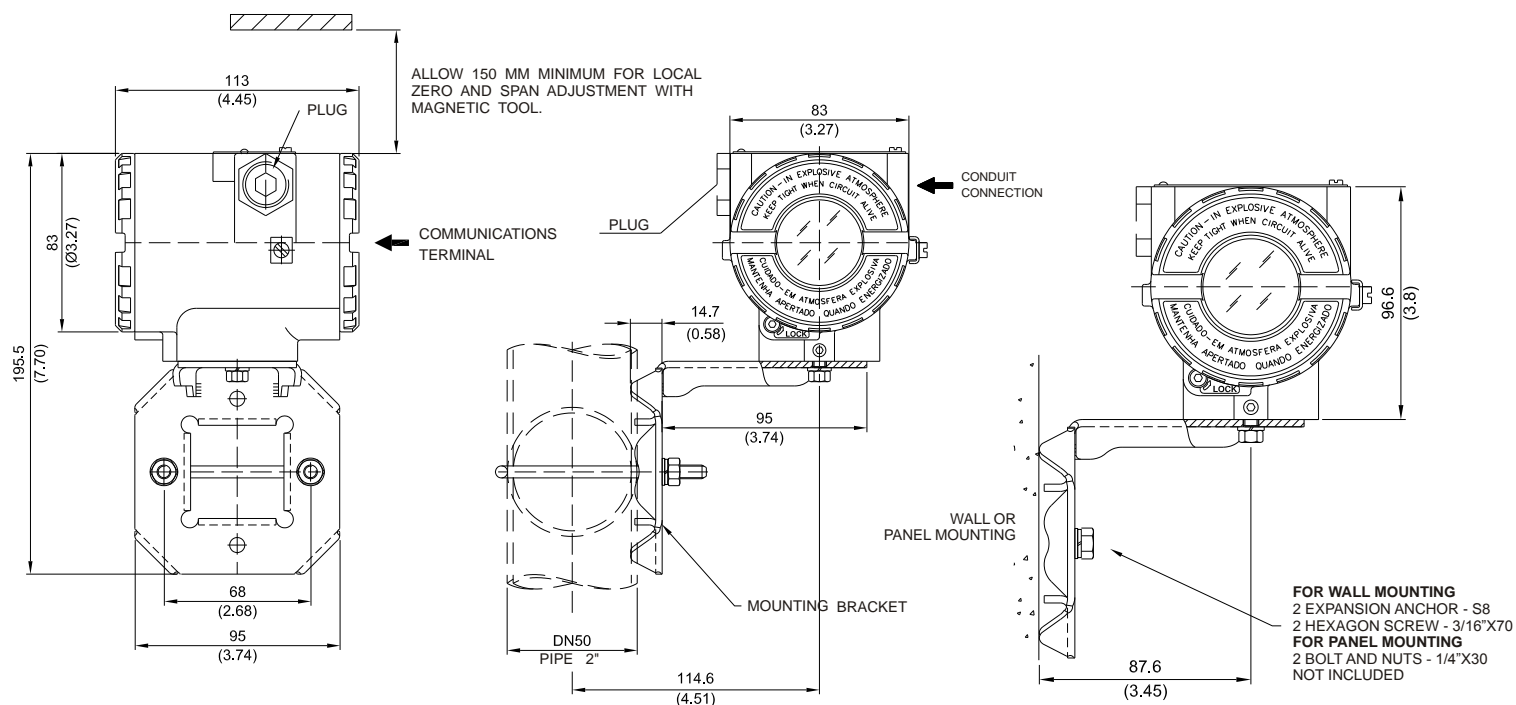

Figure 1.3 - Dimensional Drawing and Mounting Positions

The **TT302** uses the 31.25 kbit/s voltage mode option for the physical signaling. All other devices on the same bus must use the same signaling. All devices are connected in parallel along the same pair of wires.

Various types of Fieldbus devices may be connected on the same bus. The **TT302** is powered via the bus. The limit for such devices is 16 for one bus for non-intrinsically safe requirement.

In hazardous areas, the number of devices may be limited to 6 devices by intrinsically safe restrictions.

The **TT302** is protected against reverse polarity, and can withstand ± 35 VDC without damage.

Use of twisted pair cables is recommended. It is also recommended to ground shield of shielded cables at one end only. The non-grounded end must be carefully isolated.

NOTE

Please refer to the General Installation, Operation and Maintenance Manual for more details.

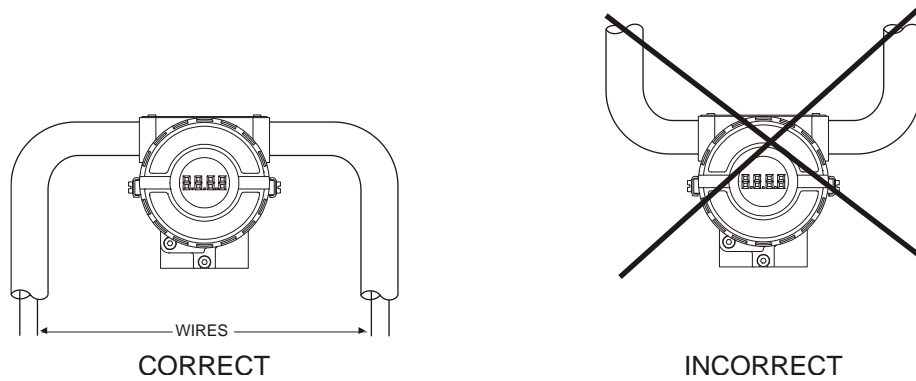

Figure 1.4 - Conduit Installation Diagram

Bus Topology and Network Configuration

Special requirements are applied to the terminator when used in a safety bus.

Intrinsic Safety Barrier

When intrinsic safety is required, a barrier should be inserted on the trunk between the power supply and the terminator.

The barrier's impedance should be greater than 460Ω at 7.8 to 39 kHz.

The capacitance measured on both ends should not have a difference greater than 250pF from each other. The DF47 is recommended. See more in <http://www.smar.com/products/df47-12.asp>.

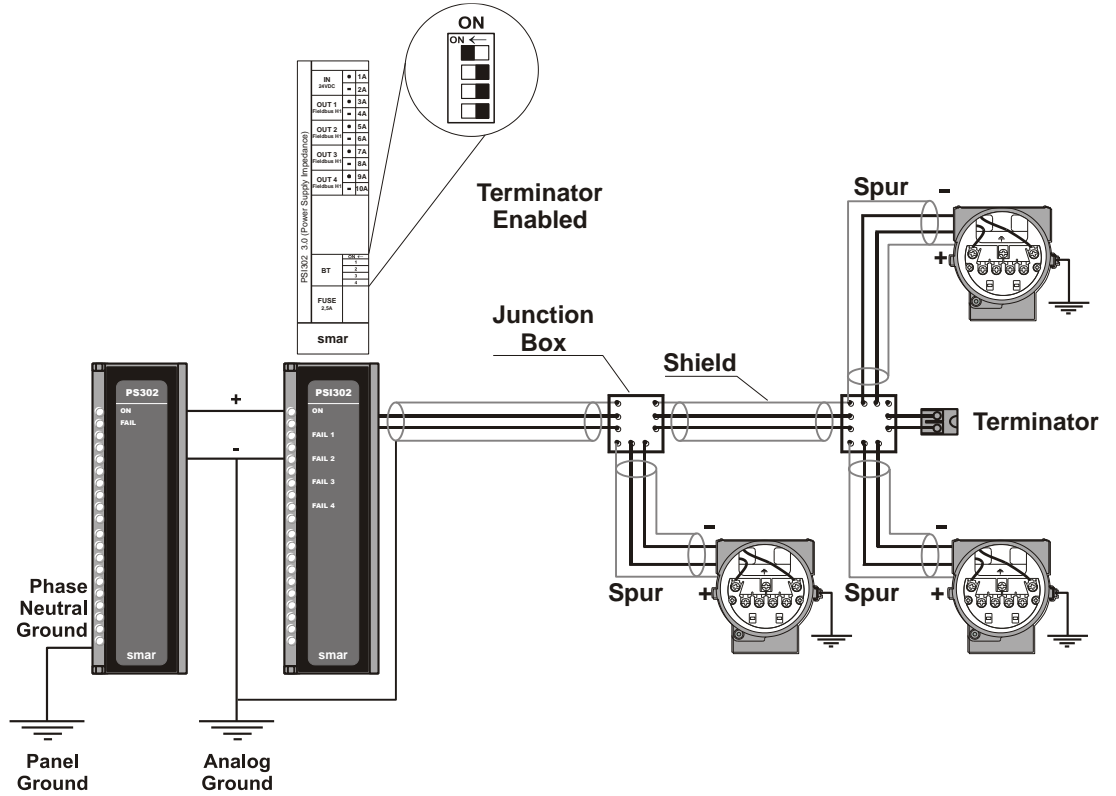

Figure 1.5 - Bus Topology

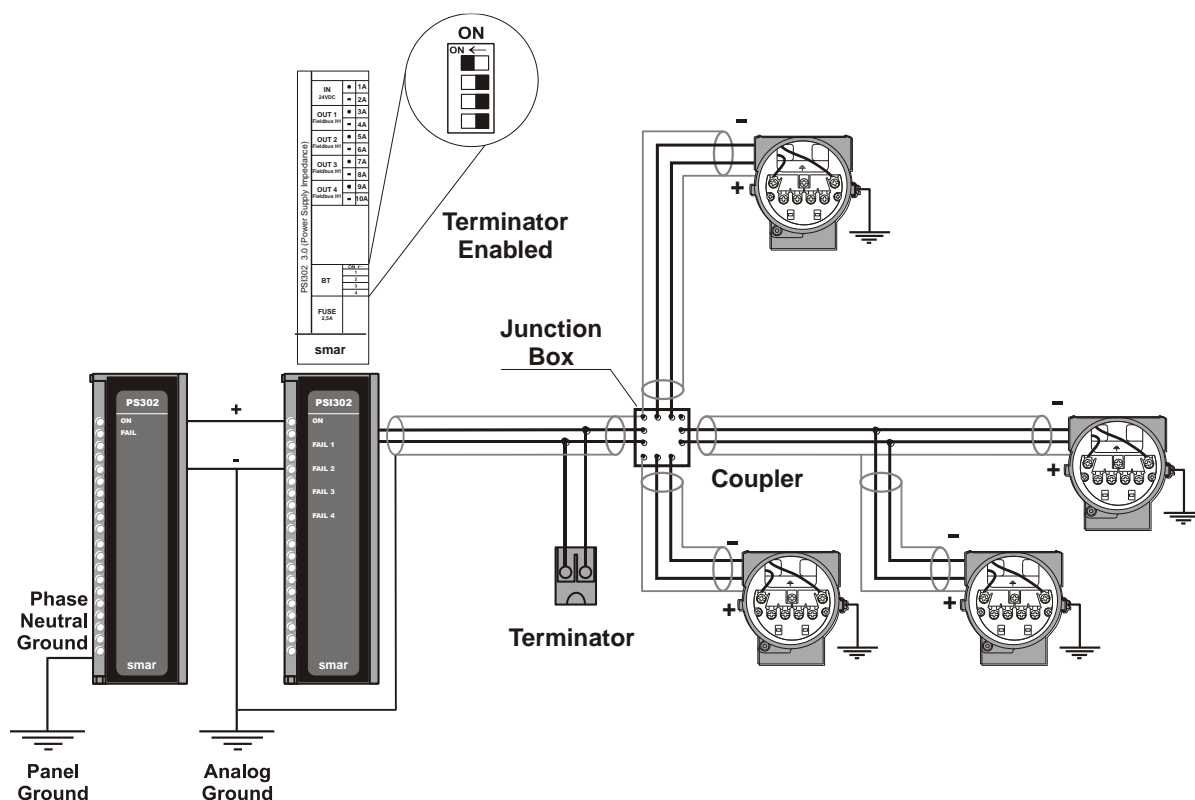

Figure 1.6 - Bus Topology

Sensor Wiring

The TT302 accepts up to two sensors and may operate in one of four modes:

- Single channel single sensor measurement
- Dual channel dual sensor measurement
- Single channel dual sensor differential measurement.
- Single channel dual sensor backup measurement.

When the sensor is dual, the sensor connected between terminals 3 and 4 is associated with the first transducer, and the sensor connected between terminals 2 and 4 is associated with the second transducer.

NOTE

Avoid routing sensor wiring close to power cables or switching equipment.

In accordance with connection and sensor types, the terminal blocks shall be wired as shown in figure below (See Figure 1.7).

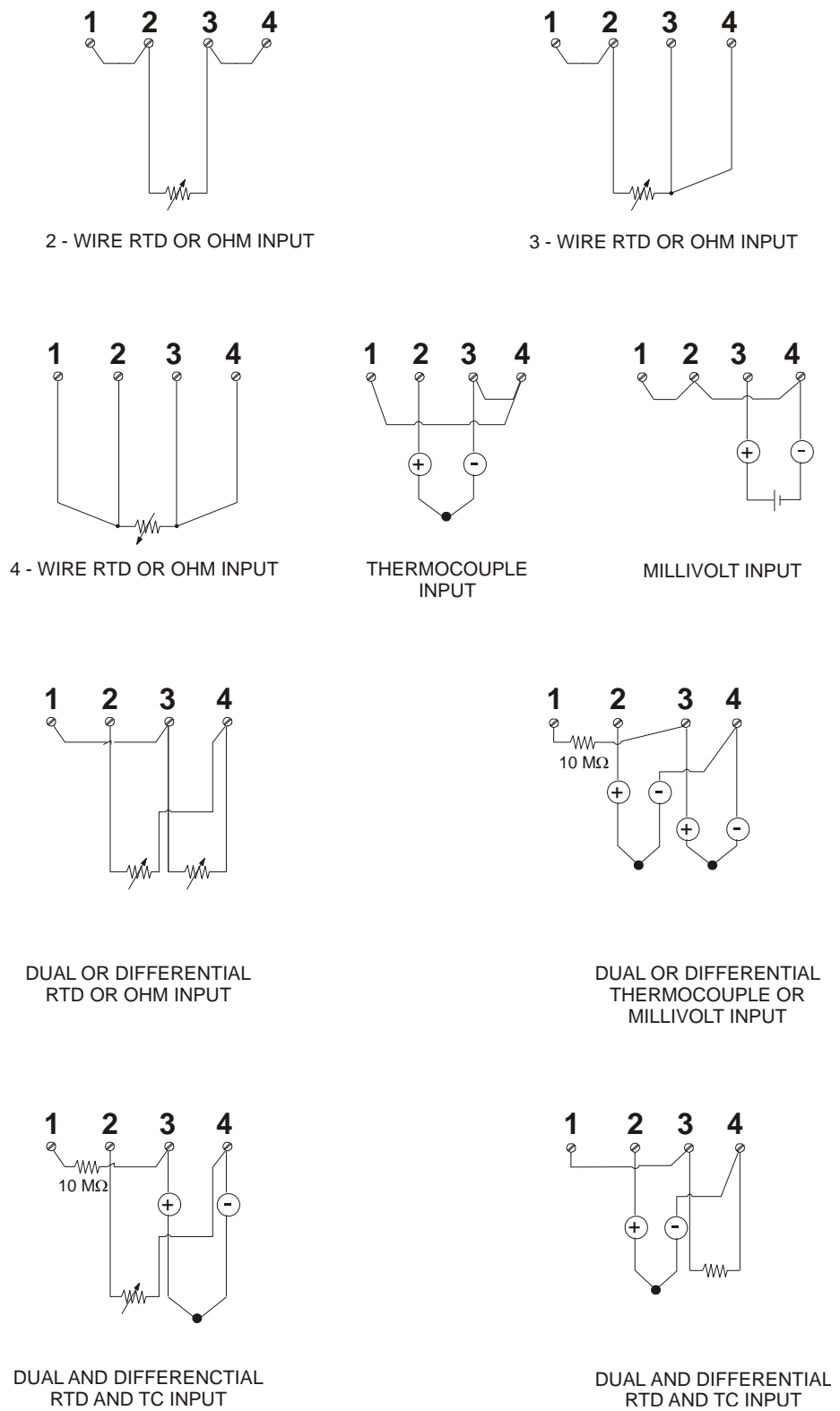

Figure 1.7 - Sensor Wiring

Installation in Hazardous Areas

WARNING

Explosions could result in death or serious injury, besides financial damage. Installation of this transmitter in explosive areas must be carried out in accordance with the local standards and the protection type adopted. Before continuing the installation make sure the certificate parameters are in accordance with the classified area where the equipment will be installed.

The instrument modification or parts replacement supplied by other than authorized representative of Smar is prohibited and will void the certification.

The transmitters are marked with options of the protection type. The certification is valid only when the protection type is indicated by the user. Once a particular type of protection is selected, any other type of protection can not be used.

Explosion/Flame Proof

WARNING

Only use Explosion Proof/Flameproof certified Plugs, Adapters and Cable glands.

In Explosion-Proof installations the cable entries must be connected or closed using metal cable gland and metal blanking plug, both with at least IP66 and Ex-d certification.

The standard plugs provided by Smar are certified according to CEPEL certificate. If the plug needs to be replaced, a certified plug must be used.

The electrical connection with NPT thread must use waterproofing sealant. A non-hardening silicone sealant is recommended.

For NEMKO ATEX certificate please to follow the installation guidelines in hazardous locations below: Group II Category 2G, Ex d, Group IIC, Temperature Class T6, EPL Gb U = 28VDC

Ambient Temperature: -20 to 60°C for T6

Environmental Protection: IP66/687 or IP66W/687W

The electrical connection available are ½ - 14NPT and M20x1,5.

Cable entries must be connected or closed using metal cable gland and metal blanking plug, both with at least IP66 and Ex-d certification or any appropriate ATEX approved metal cable gland and metal blanking plug. Do not remove the transmitter covers when power is ON.

Intrinsically Safe

WARNING

In hazardous zones with intrinsically safe or non-incendive requirements, the circuit entity parameters and applicable installation procedures must be observed.

To protect the application the transmitter **must be connected to a barrier**. Match the parameters between barrier and the equipment (Consider the cable parameters). Associated apparatus ground bus shall be insulated from panels and mounting enclosures. Shield is optional. If used, be sure to insulate the end not grounded. Cable capacitance and inductance plus C_i and L_i must be smaller than C_o and L_o of the associated Apparatus.

It is not recommended to remove the transmitter cover when the power is ON.

Section 2

OPERATION

The TT302 accepts signals from mV generators such as thermocouples or resistive sensors such as RTDs. The criterion is that the signal is within the range of the input. For mV, the range is -50 to 500 mV and for resistance, 0-2000 Ohm.

Functional Description – Hardware

The function of each block is described below.

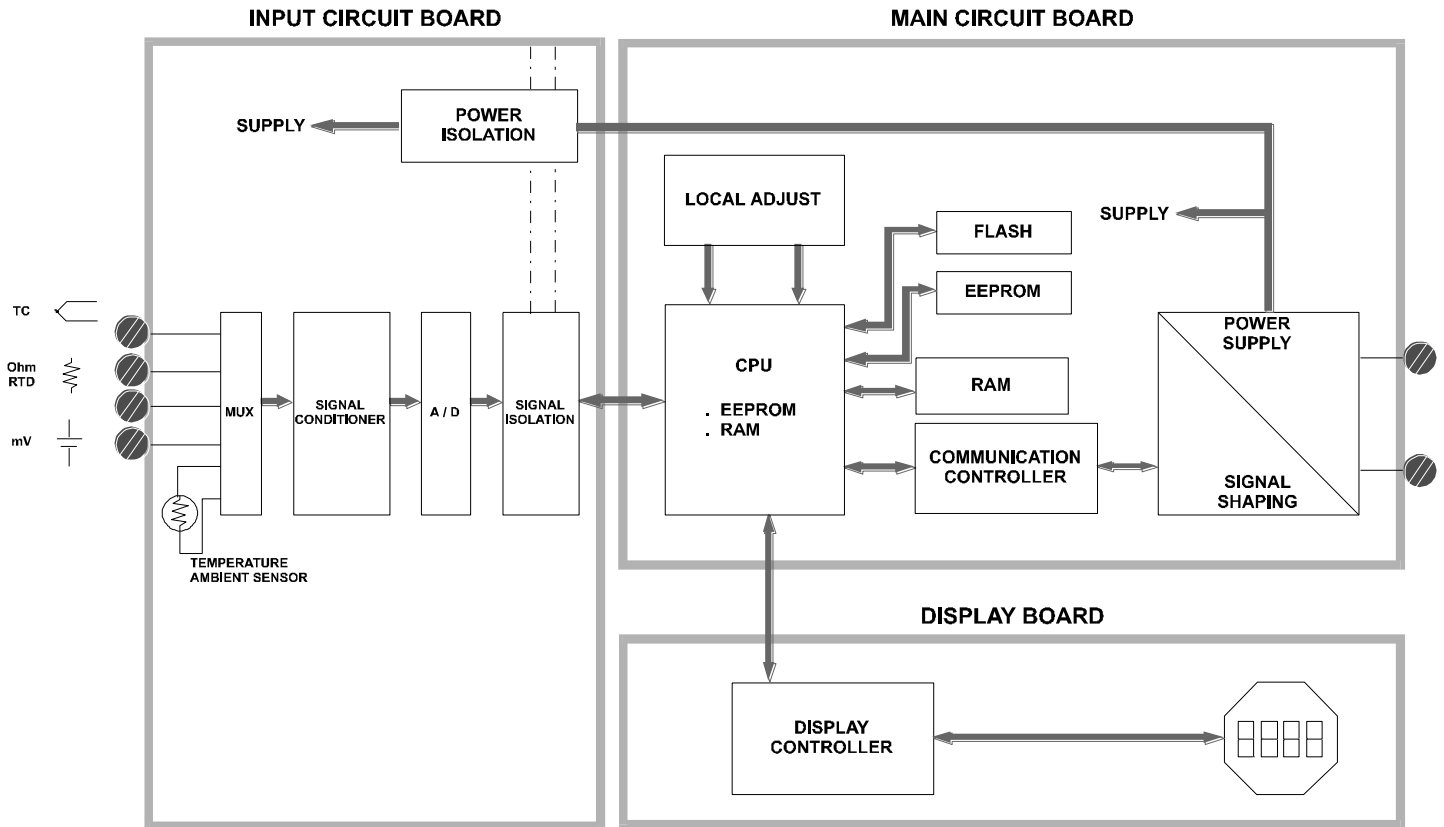

Figure 2.1 - TT302 Block Diagram

MUX Multiplexer

The MUX multiplexes the sensor terminals to the signal conditioning section ensuring that the voltages are measured between the correct terminals.

Signal Conditioner

Its function is to apply the correct gain to the input signals to make them suit the A/D - converter.

A/D Converter

The A/D converts the input signal to a digital format for the CPU.

Signal Isolation

Its function is to isolate the control and data signal between the input and the CPU.

(CPU) Central Processing Unit, RAM, PROM and EEPROM

The CPU is the intelligent portion of the transmitter, being responsible for the management and operation of measurement, block execution, self-diagnostics and communication. The program is stored in a PROM. For temporary storage of data there is a RAM. The data in the RAM is lost if the power is switched off. However there is a nonvolatile EEPROM where data that must be retained is stored. Examples, of such data are trim, calibration, block configuration and identification data.

Communication Controller

It monitors line activity, modulates and demodulates communication signals and inserts and deletes start and end delimiters.

Power Supply

Takes power of the loop-line to power the transmitter circuitry.

Power Isolation

Just like the signals to and from the input section, the power to the input section must be isolated. Isolation is achieved by converting the DC supply into a high frequency AC supply and galvanically separating it using a transformer.

Display Controller

Receives data from the CPU informing which segments of the Liquid Crystal Display, should be turned on.

Local Adjustment

There are two switches that are magnetically activated. They can be activated by the magnetic tool without mechanical or electrical contact.

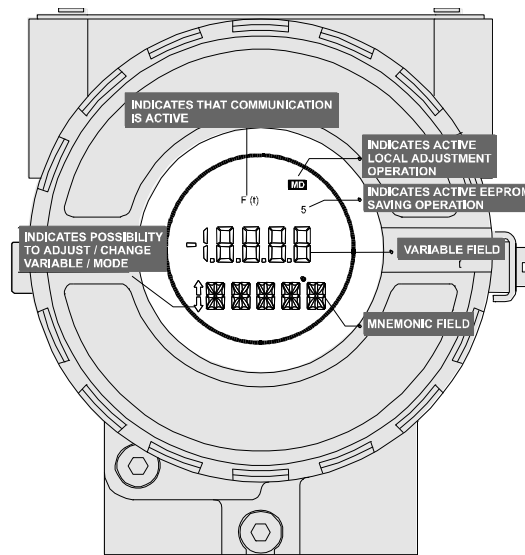

Figure 2.2 - LCD Indicator

Temperature Sensors

The **TT302**, as previously explained, accepts several types of sensors. The **TT302** is specially designed for temperature measurement using thermocouples or Resistive Temperature Detectors (RTDs).

Some basic concepts about these sensors are presented below.

Thermocouples

Thermocouples are constructed with two wires made from different metals or alloys joined at one end, called measuring junction or "hot junction". The measuring junction should be placed at the point of measurement. The other end of the thermocouple is open and connected to the temperature transmitter. This point is called reference junction or cold junction.

For most applications, the **Seebeck** effect is sufficient to explain thermocouple behavior as following:

How the Thermocouple Works (Seebeck Effect)

When there is a temperature difference along a metal wire, a small electric potential, unique to every alloy, will occur. This phenomenon is called *Seebeck* effect. When two wires of dissimilar metals are joined at one end, and left open at the other, a temperature difference between the two ends will result in a voltage since the potentials generated by the dissimilar materials are different and do not cancel each other out. Now, two important things must be noted. First: the voltage generated by the thermocouple is proportional to the difference between the measuring-junction and the cold junction temperatures. Therefore the temperature at the reference junction must be added to the temperature derived from the thermocouple output, in order to find the temperature measured. This is called cold junction compensation, and is done automatically by the **TT302**, which has a temperature sensor at the sensor terminals for this purpose. Secondly, if the thermocouple wires are not used, all the way to the terminals of the transmitter (e.g., copper wire is used from sensor-head or marshaling box) will form new junctions with additional Seebeck effects. It will be created and ruin the measurement in most cases, since the cold-junction compensation will be done at the wrong point.

NOTE

Use thermocouple wires or appropriate extension wires all the way from sensor to transmitter.

The relation between the measuring junction temperature and the generated mili-voltage is tabulated in thermocouple calibration tables for standardized thermocouple types, the reference temperature being 0 °C.

Standardized thermocouples that are commercially used, whose tables are stored in the memory of the **TT302**, are the following:

- NBS (B, E, J, K, N, R, S & T)
- DIN (L & U)

Resistive Temperature Detectors (RTDs)

Resistance Temperature Detectors, most commonly known as RTD's, are based on the principle that the resistance of metal increases as its temperature increases.

Standardized RTDs, whose tables are stored in the memory of the **TT302**, are the following:

- JIS [1604-81] (Pt50 & Pt100)
- IEC, DIN, JIS [1604-89] (Pt50, Pt100 & Pt500)
- GE (Cu10)
- DIN (Ni120)

For correct measurement of RTD temperature, it is necessary to eliminate the effect of the resistance of the wires connecting the sensor to the measuring circuit. In some industrial applications, these wires may be hundreds of meters long. This is particularly important at locations where the ambient temperature changes constantly.

The **TT302** permits a 2-wire connection that may cause measuring errors, depending on the length of connection wires and on the temperature to which they are exposed. (See Figure 2.3 - Two-Wire Connection).

In a 2-wire connection, the voltage V_2 is proportional to the RTD resistance plus the resistance of the wires.

$$V_2 = [RTD + 2 \times R] \times I$$

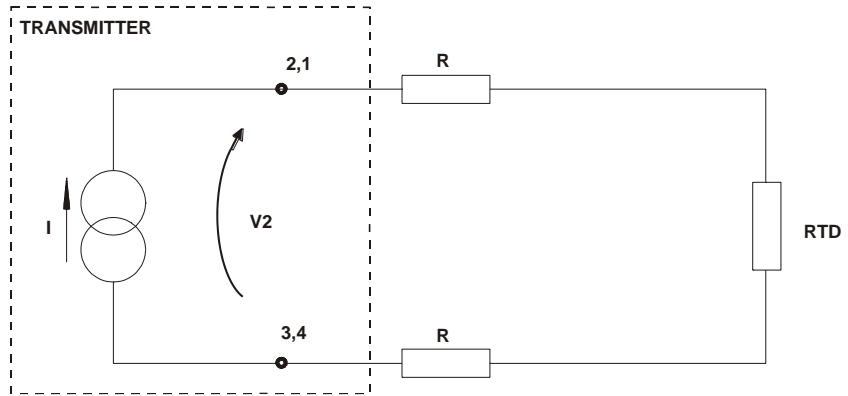

Figure 2.3 - Two-Wire Connection

In order to avoid the resistance effect of the connection wires, it is recommended to use a 3-wire connection (See Figure 2.4 – Three-Wire Connection) or a 4-wire connection (See Figure 2.5 - Four - Wire Connection).

In a 3-wire connection, terminal 3 is a high impedance input. Thus, no current flows through that wire and no voltage drop is caused. The voltage $V_2 - V_1$ is independent of the wire resistances since they will be cancelled, and is directly proportional to the RTD resistance alone.

$$V_2 - V_1 = [RTD + R] \times I - R \times I = RTD \times I$$

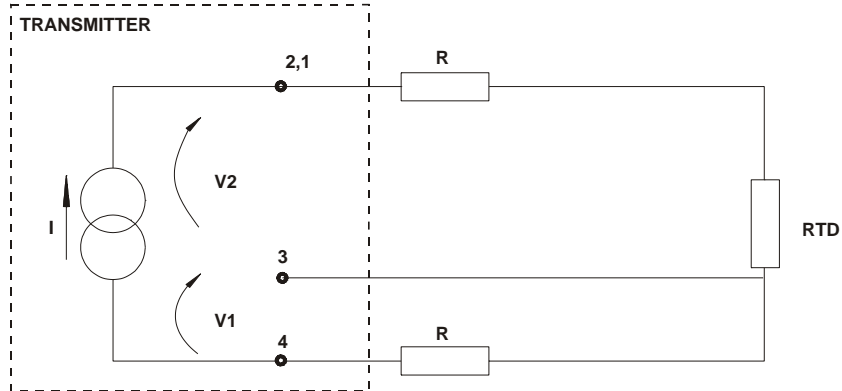

Figure 2.4 - Three – Wire Connection

In a 4-wire connection, terminals 2 and 3 are high impedance inputs. Thus, no current flows through those wires and no voltage drop is caused. The resistance of the other two wires is not of interest, since there is no measurement registered on them. Hence the voltage V_2 is directly proportional to the RTD resistance.

$(V_2 = RTD \times I)$

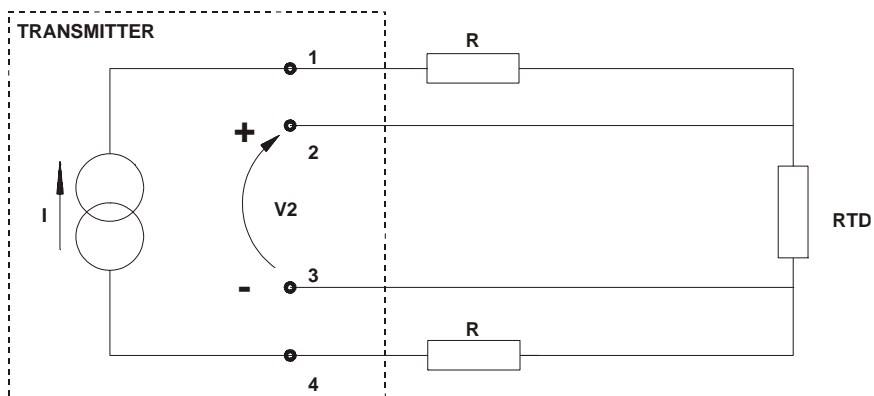

Figure 2.5 - Four - Wire Connection

A differential or dual channel connection is similar to the two-wire connection and gives the same problem (See Figure 2.6 - Differential or Dual Connection). The resistance of the wires will be measured and do not cancel each other out in a temperature measurement, since linearization will affect them differently.

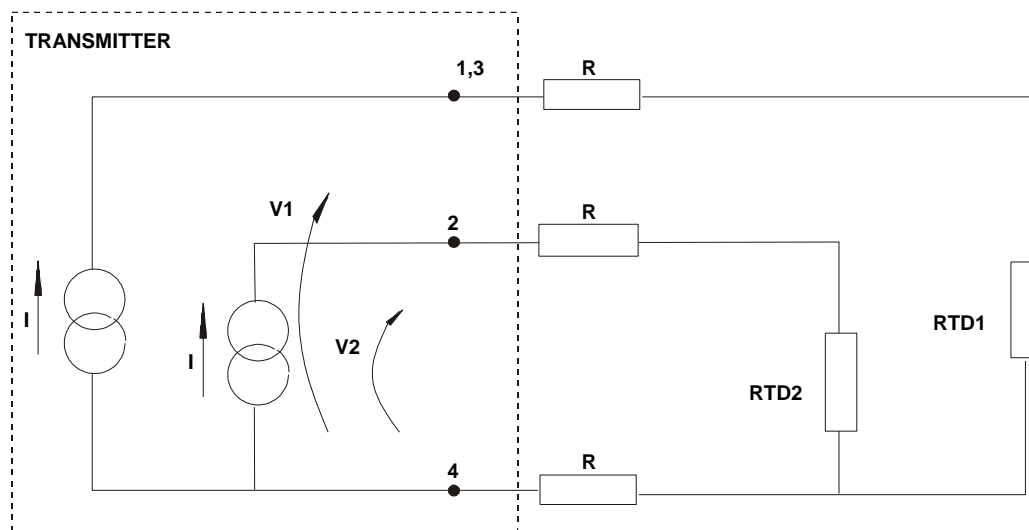

Figure 2.6 - Differential or Dual Connection

Section 3

CONFIGURATION

One of the many advantages of Fieldbus is that device configuration is independent of the configurator. The **TT302** may be configured by a third party terminal or console operator. Any particular configurator is therefore not addressed here.

The **TT302** contains two input transducer blocks, one resource block, one display transducer block and other function blocks.

For explanation and details of function blocks, see the “Function Blocks Manual”.

Transducer Block

Transducer block insulates function blocks from the specific I/O hardware (sensors and actuators). The transducer block controls the access to I/O through manufacturer specific implementation. This allows the transducer block to be executed as frequently as necessary to obtain good data from sensors without burdening the function blocks that uses the data. It also insulates the function blocks from the manufacturer specific characteristics of certain hardware.

By accessing the hardware, the transducer block can get data from the I/O or pass control data to it. The connection between Transducer block and Function block is called channel. These blocks can exchange data through the interface.

Normally, transducer blocks perform functions, such as linearization, characterization, temperature compensation, hardware control and data exchange.

Transducer Block Parameters Description

The parameters described below are used to configure the transducer block, having direct influence in the hardware.

PARAMETER	DESCRIPTION
ST_REV	Number of changes in the static parameter.
TAG_DESC	Transducer block tag.
STRATEGY	Parameter not processed by the Transducer block.
ALERT_KEY	Identification number in the plant.
MODE_BLK	Operation mode of the Transducer block.
BLOCK_ERR	Hardware and software status associated with the Transducer.
UPDATE_EVT	Static parameters alarm.
BLOCK_ALM	Alarm used by the configuration or by the hardware.
TRANSDUCER_DIRECTORY	Number and initial index of the Transducer inside the Transducer block.
TRANSDUCER_TYPE	Type of Transducer according to its class. 101 - Standard Temperature with calibration
XD_ERROR	Used to show the calibration status.
COLLECTION_DIRECTORY	Number, initial index and description device item of the Transducer, inside the Transducer block.
PRIMARY_VALUE_TYPE	Measurement type represented by the primary variable. 104 – Process Temperature 106 – Differential Temperature 120 – Backup Temperature
PRIMARY_VALUE	Measured variable and available status for the function block.
PRIMARY_VALUE_RANGE	Upper and lower limits, engineering unit, and number of decimal places used to designate the primary variable.
CAL_POINT_HI	Upper calibration value.
CAL_POINT_LO	Lower calibration value.
CAL_MIN_SPAN	Minimum span value allowed in the calibration. This minimum span is necessary to make sure that the two calibrated points (lower and upper) are not too close, when the calibration is done.
CAL_UNIT	Engineering unit used in the lower and upper calibration.
SENSOR_TYPE	Sensor type 128 – Pt100 IEC 129 – Pt100 JIS 131 – Pt500 IEC 132 – Ni 120 DIN 133 – Cu 10 GE 170 – Pt 50 IEC 171 – Pt 50 JIS 181 – Ohm 100

PARAMETER	DESCRIPTION
	180 – Ohm 400 104 – Ohm 2000 134 – TC B NBS 136 – TC E NBS 137 – TC J NBS 138 – TC K NBS 139 – TC N NBS 140 – TC R NBS 141 – TC S NBS 142 – TC T NBS 143 – TC L DIN 144 – TC U DIN 191 – mV 22 190 – mV 100 103 – mV 500
SENSOR_RANGE	Lower and upper limits, engineering unit and number of decimal point of the sensor.
SENSOR_SN	Sensor serial number.
SENSOR_CAL_METHOD	Last method of calibration of the sensor.
SENSOR_CAL_LOC	Localization of the last calibration of the sensor. That is the place where the calibration was done.
SENSOR_CAL_DATE	Date of the latest calibration of the sensor.
SENSOR_CAL_WHO	Name of the person responsible for the last calibration of the sensor.
SENSOR_CONNECTION	Number of sensor wires connected to the equipment terminal blocks. 1 – Dual two wires 2 – Two wires 3 – Three wires 4 – Four wires
SECONDARY_VALUE	Secondary variable related to the sensor.
SECONDARY_VALUE_UNIT	Engineering unit used by the secondary variable.
MODULE_SN	Module serial number.
SECONDARY_VALUE_ACTION	Type of action of the cold junction compensation. 0 – disabled 1 – enabled
BACKUP_RESTORE	Parameter used to restore or save the configuration data. 1 – Factory Cal Restore 2 – Last Cal Restore 3 – Default Data Restore 4 – Shut-Down Data Restore 5 – Sensor Data Restore 11 – Factory Cal Backup 12 – Last Cal Backup 14 – Shut-Down Data Backup 15 – Sensor Data Backup 0 – None
CAL_POINT_HI_LAST	Upper calibration saved by the backup_restore.
CAL_POINT_LO_LAST	Lower calibration saved by the backup_restore.
CAL_POINT_HI_FACTORY	Factory upper calibration saved by the backup_restore
CAL_POINT_LO_FACTORY	Factory lower calibration saved by the backup_restore
ORDERING_CODE	Product information to manufacture.
TWO_WIRES_COMPENSATION	Automatic compensation of the lead resistance for two wire RTD sensors or dual two wire RTD sensors. 0 – Disabled 1 – Enabled
SENSOR_TRANSDUCER_NUMBER	Number of Transducer being used: 1 – First Transducer (this one should always exist) 2 – Second Transducer (It exists if the type of connection of the first transducer is dual or two wires)

Transducer Block Parameters Types

Parameter	Data Type	Storage	Size	Initial Value	Class	View
ST_REV	Unsigned16	S	2	0	R	1,2,3,4
TAG_DESC	Octet String	S	32	Nulls	R/W	
STRATEGY	Unsigned16	S	2	0	R/W	4
ALERT_KEY	Unsigned8	S	1	0	R/W	4
MODE_BLK	DS-69	Mix	4	AUTO	R/W	1,3
BLOCK_ERR	Bit String	D	2	*	R	1,3
UPDATE_EVT	DS-73	D	5	*	R	

Parameter	Data Type	Storage	Size	Initial Value	Class	View
BLOCK_ALM	DS-72	D	13	*	R	
TRANSDUCER_DIRECTORY	Array of Unsigned16	N	Variable	*	R	
TRANSDUCER_TYPE	Unsigned16	N	2	101	R	1,2,3,4
XD_ERROR	Unsigned8	D	1	*	R	1,3
COLLECTION_DIRECTORY	Array of Unsigned16	N	Variable	*	R	
PRIMARY_VALUE_TYPE	Unsigned16	S	2	104	R/W	2
PRIMARY_VALUE	DS-65	D	5	0	R	1,3
PRIMARY_VALUE_RANGE	DS-68	NS	11	-200/850/1001/1	R	4
CAL_POINT_HI	Float	S	4	850.0	R/W	2
CAL_POINT_LO	Float	S	4	-250.0	R/W	2
CAL_MIN_SPAN	Float	N	4	10.0	R	4
CAL_UNIT	Unsigned16	S	2	1001	R/W	4
SENSOR_TYPE	Unsigned16	S	2	128	R/W	4
SENSOR_RANGE	DS-68	N	11	-200/850/1001/1	R	4
SENSOR_SN	Unsigned Long	N	4	0	R	4
SENSOR_CAL_METHOD	Unsigned8	S	1	103	R	4
SENSOR_CAL_LOC	Visible String	S	32	NULL	R/W	4
SENSOR_CAL_DATE	Time of Day	S	7	0	R/W	4
SENSOR_CAL_WHO	Visible String	S	32	NULL	R/W	4
SENSOR_CONNECTION	Unsigned8	S	1	3	R/W	4
SECONDARY_VALUE	DS-65	D	5	0	R	3
SECONDARY_VALUE_UNIT	Unsigned16	S	2	1001	R/W	4
MODULE_SN	Unsigned Long	N	4	0	R	4
SECONDARY_VALUE_ACTION	Unsigned8	S	1	1	R/W	
BACKUP_RESTORE	Unsigned8	S	1	0	R/W	4
CAL_POINT_HI_LAST	Float	S	4	850.0	R	2
CAL_POINT_LO_LAST	Float	S	4	-200.0	R	2
CAL_POINT_HI_FACTORY	Float	S	4	850.0	R	2
CAL_POINT_LO_FACTORY	Float	S	4	-200.0	R	2
ORDERING_CODE	Visible String	S	50	Null	R/W	
TWO_WIRE_COMPENSATION	Unsigned8	D	1	1	R/W	
SENSOR_TRANSD_NUMBER	Unsigned8	S	1	0	R/W	4

D: Dynamic
N: Non-volatile
S: Static

How to Configure a Transducer Block

The transducer block has an algorithm, a set of contained parameters (it means you are not able to link these parameters to other blocks or publish the link via communication), and a channel connecting it to a function block.

The algorithm describes the behavior of the transducer as a data transfer function between the I/O hardware and other function block. The set of contained parameters defines the user interface to the transducer block. They can be divided into Standard and Manufacturer Specific.

The standard parameters are defined specifically to each device class such as, pressure, temperature, etc., no matter is the manufacturer. Oppositely, the manufacturers specific are only defined by the manufacturer. As common manufacturer specific parameters, we have calibration settings, material information, linearization curve, etc.

When you perform a standard routine such as calibration, you are conducted step by step by a method. The method is generally defined as guideline to help the user make common tasks. **SYSCON** identifies each method associated to the parameters and enables the interface to it.

Sensor Transducer Number

The Sensor Transducer Number associates the sensor to the transducer. It can be set from one up to two, in case of dual sensor.

Jumper Configuration

In order to work properly, the jumpers **J1** and **W1** located in the **TT302** main board must be correctly configured.

J1 is responsible to enable the AI block simulate mode.

W1 is responsible to enable the local adjustment.

Sensor Configuration



It is necessary to configure the transducer number allocated to its task. The parameter `SENSOR_TRANSDUCER_NUMBER` should be set to 1.

This parameter sets the transducer number, according to the type of temperature measurement.

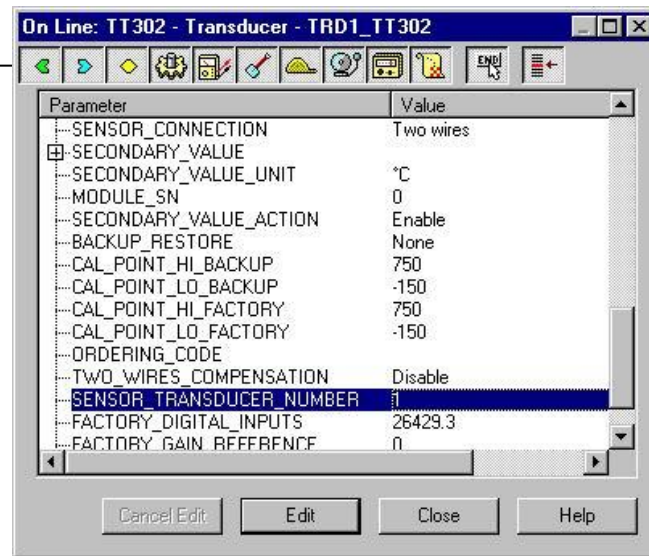

This parameter could be 1 or 2, for indicating respectively first or second transducers.

Figure 3.1 – Transducer Number Configuration



It is possible to configure the type of connection and sensor by means of `SENSOR_TYPE` and `SENSOR_CONNECTION` parameters. The connection and sensor types available are listed in Table 3.1 - Sensor Type Table and Table 3.2 - Type of Connection Table, as well as the corresponding value.

This parameter selects the type of sensor attached to the **TT302** in order to measure temperature.

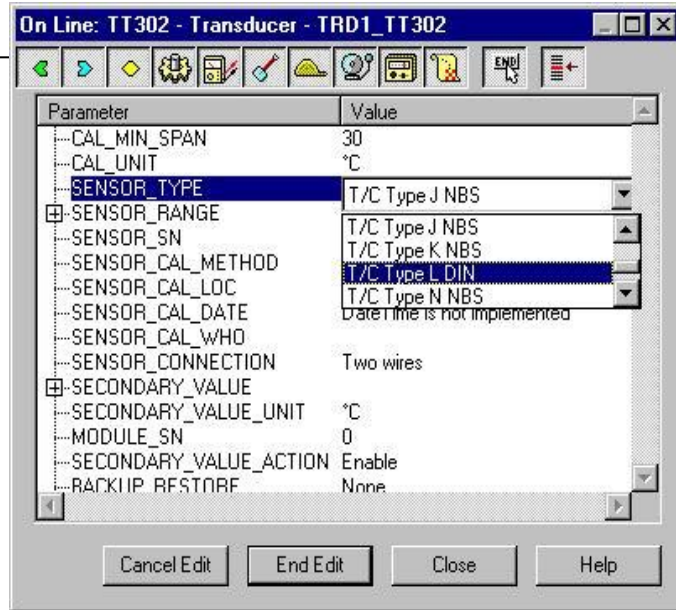

This list contains: Thermocouples, RTDs, Ohm and millivoltage.

Figure 3.2 – Sensor Type Configuration

NOTE

There are no 3 or 4 wire connections for millivoltage sensors.

This parameter selects the type of sensor connection. The options here will depend on Sensor Type chosen as described above.

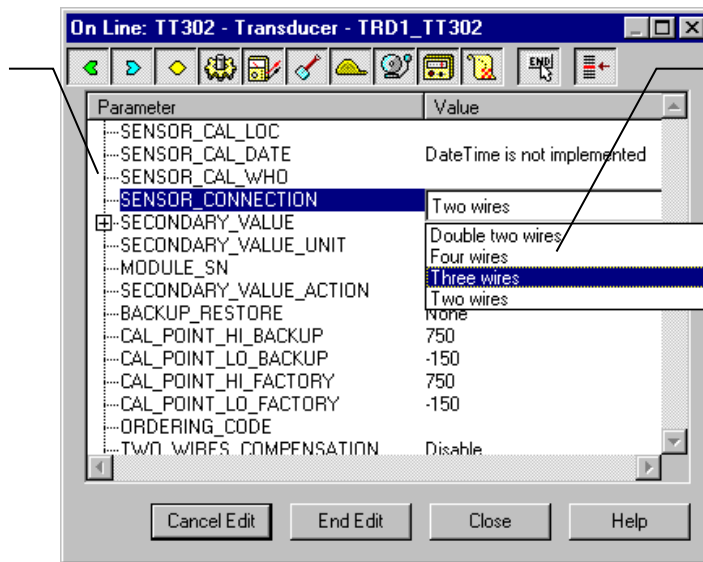

This list contains the number of wires available for each type of sensor.

Figure 3.3 – Sensor Type Connection Configuration

SENSOR_TYPE	ADJUST LOCAL VALUE
Pt 100 IEC	128
Pt 100 JIS	129
Pt 500 IEC	131
Ni 120 DIN	132
Cu 10 CE	133
Pt 50 IEC	170
Pt 50 JIS	171
Ohm 100	181
Ohm 400	180
Ohm 2,000	104
TC B NBS	134
TC E NBS	136
TC J NBS	137
TC K NBS	138
TC N NBS	139
TC R NBS	140
TC S NBS	141
TC T NBS	142
TC L DIN	143
TC U DIN	144
mV 22	191
mV 100	190
mV 500	103

Table 3.1 - Sensor Type Table

CONNECTION	ADJUST LOCAL VALUE
DOUBLE TWO WIRE	1
TWO WIRE	2
THREE WIRE	3
FOUR WIRE	4

Table 3.2 - Type of Connection Table

How to Connect Two Sensors to TT302



Transmitters series **TT302** are capable of operating simultaneously with two sensors, using two transducer blocks, if necessary. Configuration types in two sensors operation are as follows:

Differential – In this case there is only one transducer. Transducer output is the difference between the readout of sensor 1 (between terminals 3 and 4) and the readout of sensor 2 (between terminals 2 and 4). The PRIMARY_VALUE_TYPE parameter should be configured as differential temperature.

Backup – In this case there is only one transducer.

When the first sensor (between terminals 3 and 4) breaks down, the second sensor (between terminals 2 and 4) will supply the signal to the transducer.

Double - In this case there are two transducers. Each sensor provides a signal to its respective transducer.

In order to be able to operate with sensors in the backup or differential modes, the parameter PRIMARY_VALUE_TYPE must be set. In order to operate with double sensors, the parameter SENSOR_CONNECTION must be set.

This parameter sets the type of calculation that should be done for each transducer.

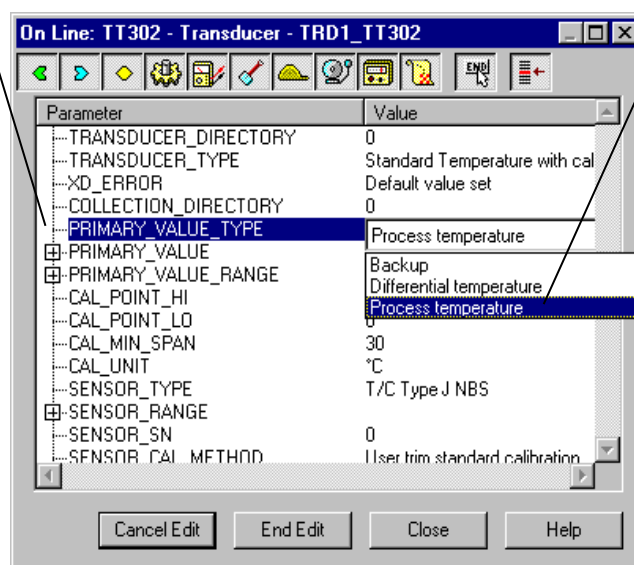

This list contains the normal option, Backup and Differential type of temperature calculation.

Figure 3.4 – Primary Variable Type Configuration

Compensation of Lead Resistance for Double Sensor (RTD or Ohm)

When 2 wire resistive sensors are used, the readout is not a very accurate because of the resistance of leads connecting sensor to transmitter. In order to reduce this error, it is possible to configure the transmitter to compensate for a constant lead resistance by means of parameter LEAD_RESISTANCE_VALUE.

As explained, 2 wire resistive sensors are not accurate due to lead resistance. For this reason, 3 or 4 wire sensors are usually preferred.

With **TT302** is possible to connect two sensors to the terminal block. Due to space limitations in the terminal block, it is only possible to connect two 2-wire sensors. In order to optimize lead resistance compensation for these sensors and to minimize error, there is the parameter TWO_WIRES_COMPENSATION that automatically calculates the lead resistance. All the user is required to do is to short-circuit the sensor in the field and to actuate this parameter (Enable). After undo the short circuit the measurement will be more accuracy.

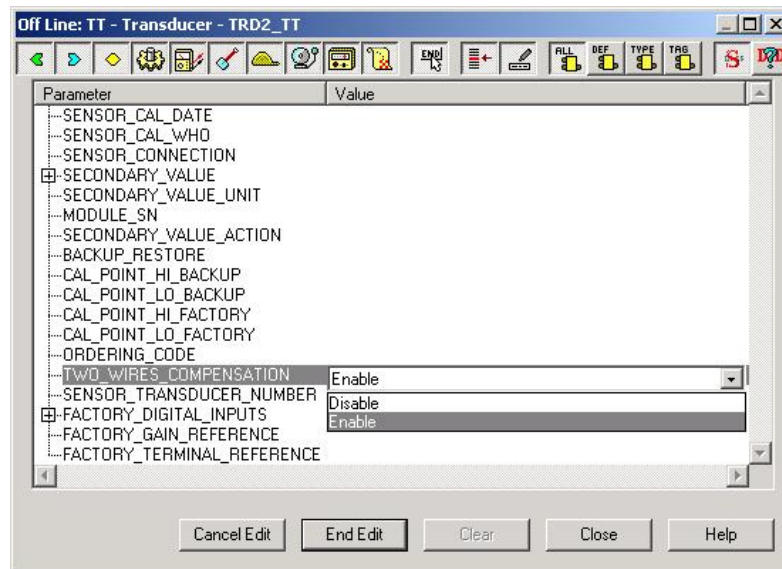

Figure 3.5 – Lead Resistance Compensation

Cold Junction Compensation

The cold junction compensation for thermocouple sensors is done automatically, but it can be disabled by writing DISABLE on the parameter SECONDARY_VALUE_ACTION.

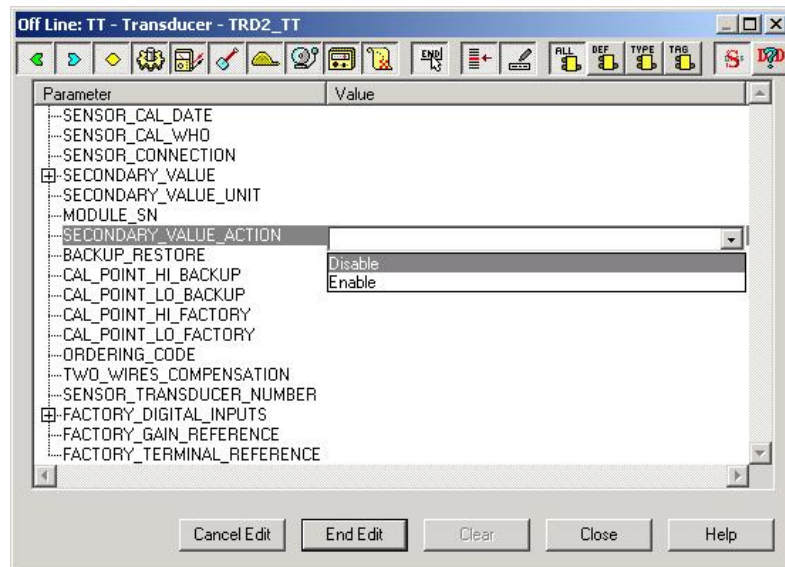

Figure 3.6 – Cold Junction Compensation

Calibration in TT302 by the User

The electronics of **TT302** is very stable in time, not requiring further calibrations after manufacturer's calibration. However, if the client decides to use his reference to calibrate the **TT302**, this may be done through the parameters CAL_POINT_LO and CAL_POINT_HI. Always use two points as reference when trim is performed; never consider only one point as a reference.

NOTE

Every time the sensor is changed, the TRIM values are reset. If a TC is used, it is not necessary to disable the cold Junction Compensation before starting calibration procedures. Trim is not available for TT using two sensors and it is not necessary to set the Transducer Block to Out of Service.

The PRIMARY_VALUE parameter is always used to inform the current reading of the input sensor.

In order to do the Lower Trim, first put the sensor into a place with known temperature. If the PRIMARY_VALUE parameter shows a temperature different from the expected, the Lower trim should be done by writing the desired temperature in the CAL_POINT_LO parameter. The adjust trim results can be seen in the PRIMARY_VALUE parameter.

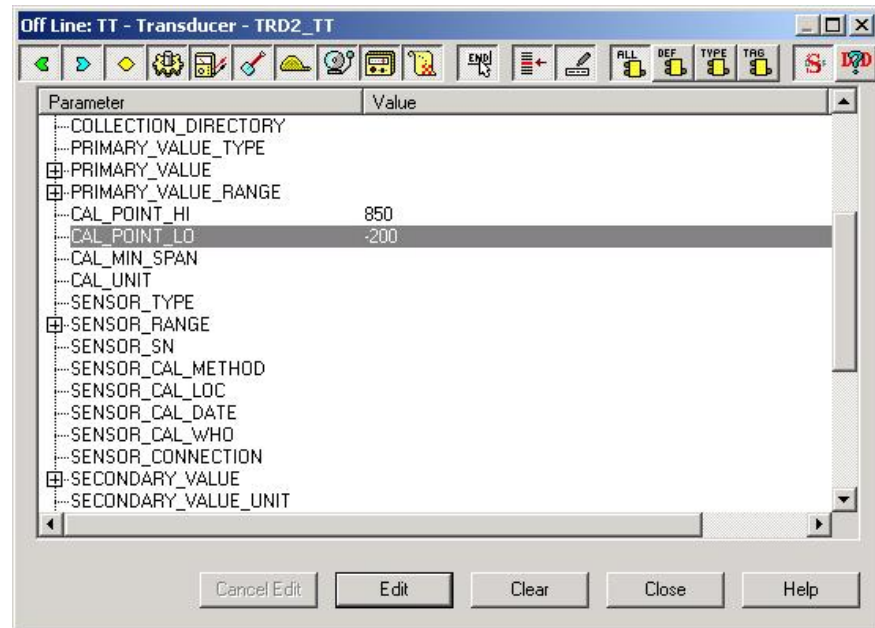

Figure 3.7 – Calibration of the Lower Trim - TT302

In order to do the Upper Trim, first put the sensor into a place with a higher temperature than the lower calibration point. If the PRIMARY_VALUE parameter shows a temperature different from the expected, the Upper trim should be done by writing the desired temperature in the CAL_POINT_HI parameter. The adjust trim results can be seen in the PRIMARY_VALUE parameter.

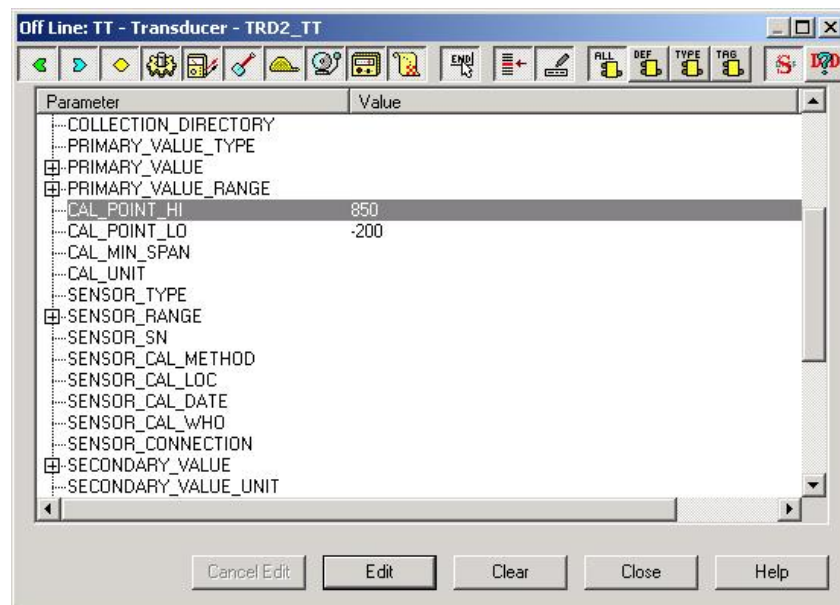

Figure 3.8 – Calibration of the Upper Trim - TT302

Trim is not available for **TT302** using two sensors in the backup or differential mode.

Changing Units in Temperature Sensors

The following units are available for temperature sensors: Celsius, Rankine, Kelvin and Fahrenheit. The units values are shown in Table 3.3 - Unit Table.

The unit can be changed in the AI block by the parameter XD_SCALE.

UNIT	VALUE
KELVIN	1000
CELSIUS	1001
FAHRENHEIT	1002
RANKINE	1003

Table 3.3 - Unit Table

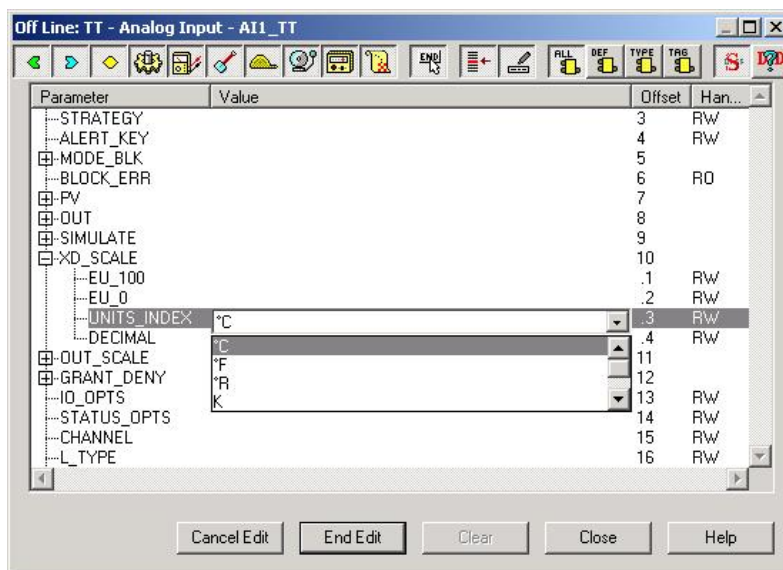

Figure 3.9 – Temperature Sensor Unit

Transducer Display – Configuration

Using the SYSCON is possible to configure the Display Transducer block. As the name described it is a transducer due the interfacing of its block with the LCD hardware.

The Transducer Display is treated as a normal block by **SYSCON**. It means, this block has some parameters can be configured according to customer's needs. (See the Figure 3.11 – Creating Transducers and Function Blocks).

The user can choose the parameters to be shown at LCD display, they can be parameters just for monitoring purpose or for acting locally in the field devices by using a magnetic tool.

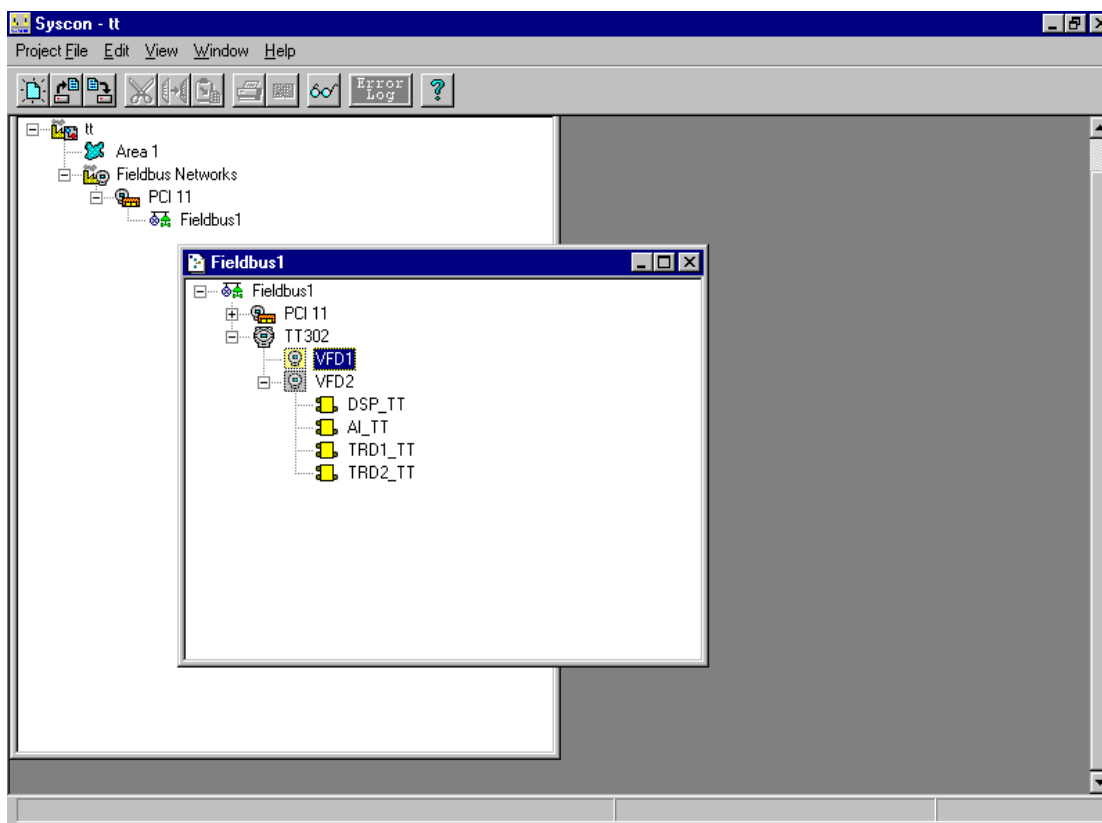

Figure 3.10 – Creating Transducers and Function Blocks

Display Transducer Block

There are seven groups of parameters which may be pre-configured by the user in order to enable a possible configuration by means of the local adjustment. As an example, let's suppose that you don't want to show some parameters; in this case, simply write an invalid Tag in the parameter. By doing this, the device will not take the parameters related (indexed) to its Tag as valid parameters.

Definition of Parameters and Values

Idx	Parameter	Data Type (length)	Valid Range/Options	Default Value	Units	Store	Description
7	BLOCK_TAG_PARAM	VisibleString			None	S	This is a tag of the block to which the parameter belongs to use up to a maximum of 32 characters.
8	INDEX_RELATIVE	Unsigned16	0-65535		None	S	This is the index related to the parameter to be actuated or viewed (1, 2...).
9	SUB_INDEX	Unsigned8	1-255		None	S	To visualize a certain tag, opt for the index relative equal to zero, and for the sub-index equal to one.
10	MNEMONIC	VisibleString			None	S	This is the mnemonic for the parameter identification (maximum of 16 characters). Choose the mnemonic, preferably with no more than 5 characters because, this way, it will not necessary to rotate it on display.
11	INC_DEC	Float			None	S	It is the increment and decrement in decimal units when the parameter is Float or Float Status time, or integer, when the parameter is in whole units.
12	DECIMAL_POINT_NUMBER	Unsigned8	0-4		None	S	This is the number of digits after the decimal point (0 to 3 decimal digits)

Idx	Parameter	Data Type (length)	Valid Range/Options	Default Value	Units	Store	Description
13	ACCESS	Unsigned8	Monit/Action		None		The access allows the user to read, in the case of the "Monitoring" option, and to write when "action" option is selected, and then the display will show the increment and decrement arrows.
14	ALPHA_NUM	Unsigned8	Mnem/Value		None	S	These parameters include two options: value and mnemonic. In option value it is possible to display data both in the alphanumeric and in the numeric fields, this way, in the case of a data higher than 10000, it will be shown in the alphanumeric field.
63	DISPLAY_REFLESH	Unsigned8	1		None	D	Update the display transducer block configuration. Used in online monitoring.

In option mnemonic, the display may show the data in the numeric field and the mnemonic in the alphanumeric field.



In case you wish to visualize a certain tag, opt for the index relative equal to zero, and for the sub-index equal to one (refer to paragraph Structure Block in the Function Blocks Manual).

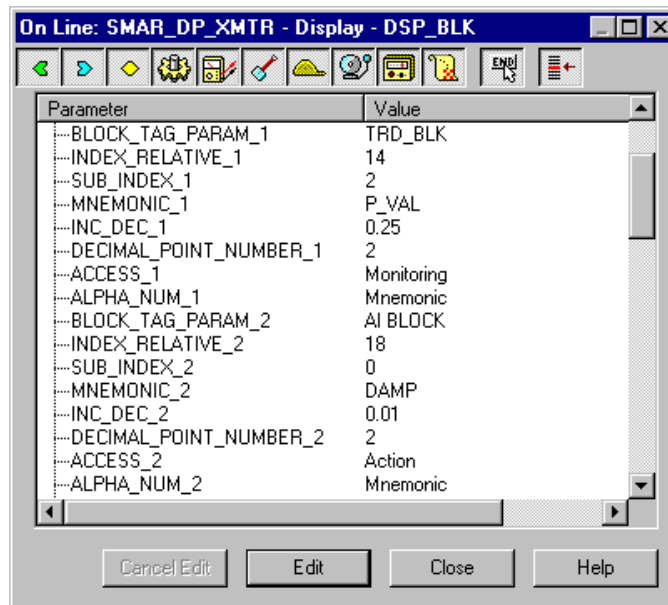

Figure 3.11 - Parameters for Local Adjustment Configuration

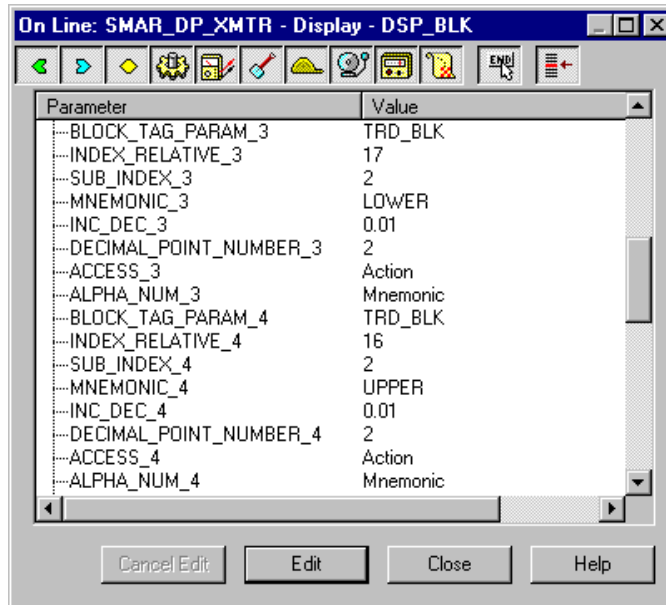

Figure 3.12 - Parameters for Local Adjustment Configuration

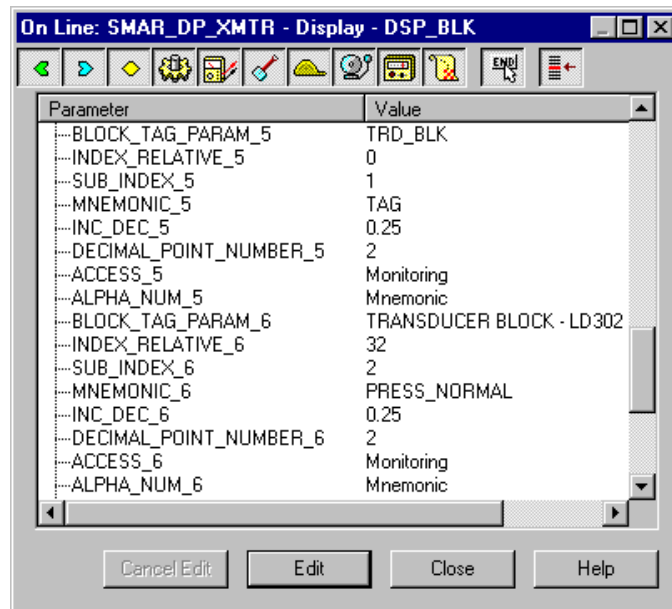

Figure 3.13 - Parameters for Local Adjustment Configuration

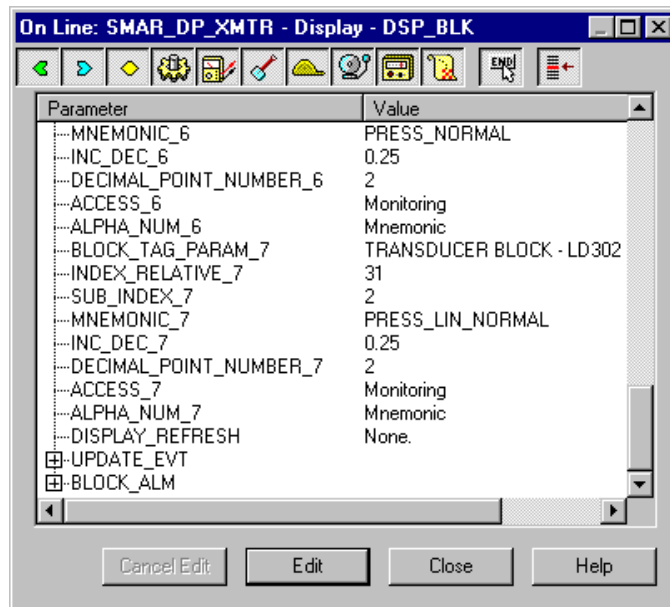
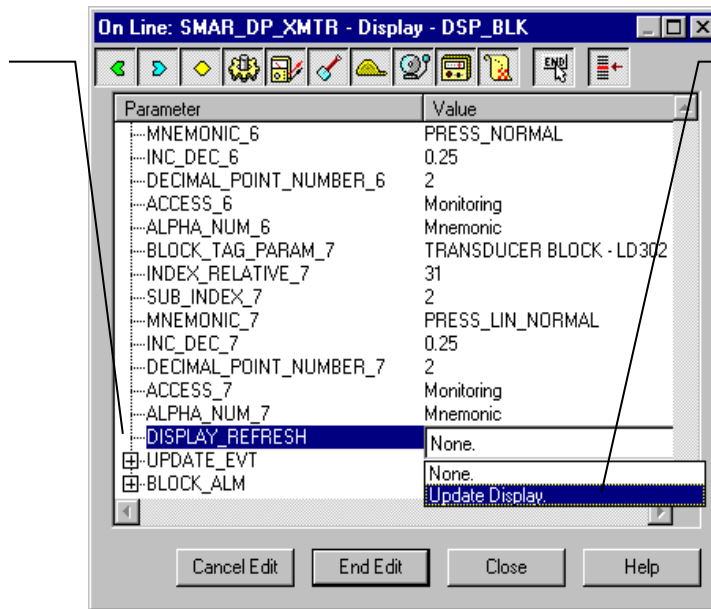

Figure 3.14 - Parameters for Local Adjustment Configuration

This parameter updates the local adjustment programming tree configured on each device.



The option "update" should be selected in order to execute the upgrade of local adjustment programming tree.

After its step all the parameters selected will be show on the LCD display.

Figure 3.15 - Parameters for Local Adjustment Configuration

Programming Using Local Adjustment

The local adjustment can not configure all the parameters as SYSCON can. It means the user can select the best options for this application. From the factory, it is configured with the options to set the Upper and Lower trim, for monitoring the transducer output and check the Tag. Usually, the transmitter is much better configured by SYSCON, but the local functionality of the LCD allows an easy and fast action on certain parameters, since it does not rely on communication and network wiring connections. Among the possibilities of the Local Adjustment, the following options can be emphasized: Mode block, Outputs monitoring, Tag visualization and Tuning Parameters setting.

The interaction between the user and the transmitter is also described in detail on the "General Installation, Operation and Maintenance Procedures Manual". Take a look at this manual in the chapter related to "Programming Using Local Adjustment".

The **TT302** has, underneath its identification plate, two holes marked with the letters S and Z beside them. These holes give access to two magnetic switches (Reed Switch), which can be activated by the magnetic tool (See Figure 3.16).

This magnetic tool enables adjustment of the most important parameters of the blocks.

The jumper W1 on top of the main circuit board must be in place and the positioner must be fitted with digital display for access to the local adjustment. Without the display, it is not possible to do the local adjustment.

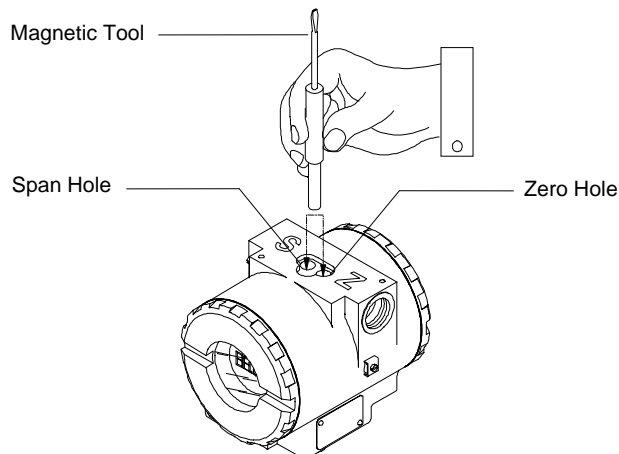

Figure 3.16 - Local Adjustment Holes

Table 3.4 shows the actions on the Z and S holes on the **TT302** when Local Adjustment is enabled.

HOLE	ACTION
Z	Initializes and rotates through the available functions.
S	Selects the function shown in the display.

Table 3.4 - Purpose of the holes on the Housing

J1 Jumper Connections

If J1 (see figure 3.18) is connected to ON, it is possible to simulate values and status through the SIMULATE parameter, from the Analog Input block.

W1 Jumper Connections

If W1 (see figure 3.18) is connected to ON, the local adjustment programming tree is enabled, and so the block parameters can be adjusted via local adjustment.

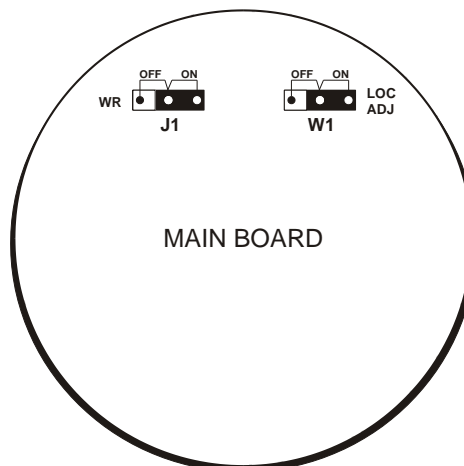
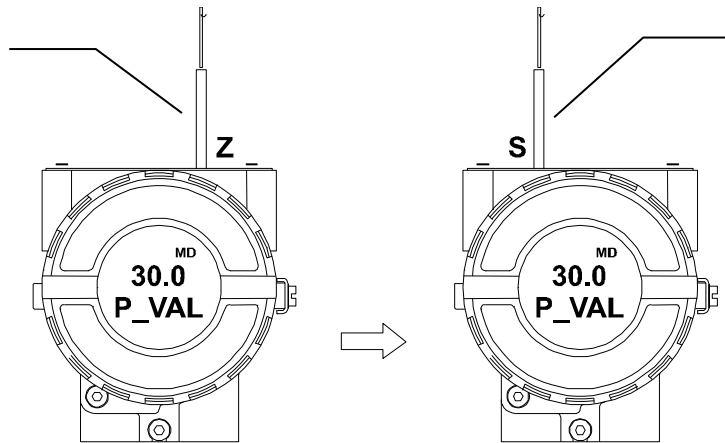

Figure 3.17 - J1 and W1 Jumpers

Local Programming Tree

In order to start the local adjustment, place the magnetic tool in orifice **Z** and wait until letters **MD** are displayed.



Place the magnetic tool in orifice **S** and wait during **5** seconds.

Figure 3.18 - Step 1 - TT302

Remove the magnetic tool from orifice **S**.

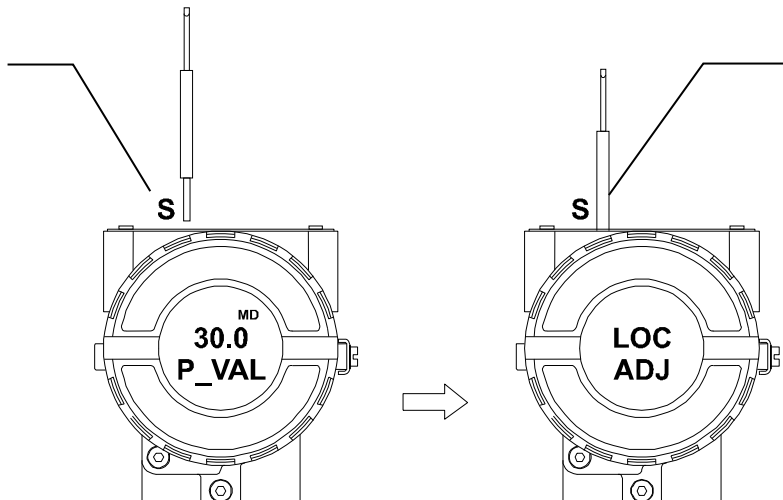

Insert the magnetic tool in orifice **S** once more and **LOC ADJ** should be displayed.

Figure 3.19 - Step 2 - TT302

Place the magnetic tool in orifice **Z**. In case this is the first configuration, the option shown on the display is the **TAG** with its corresponding mnemonic configured by the SYSCON. Otherwise, the option shown on the display will be the one configured in the prior operation. By keeping the tool inserted in this orifice, the local adjustment menu will rotate.

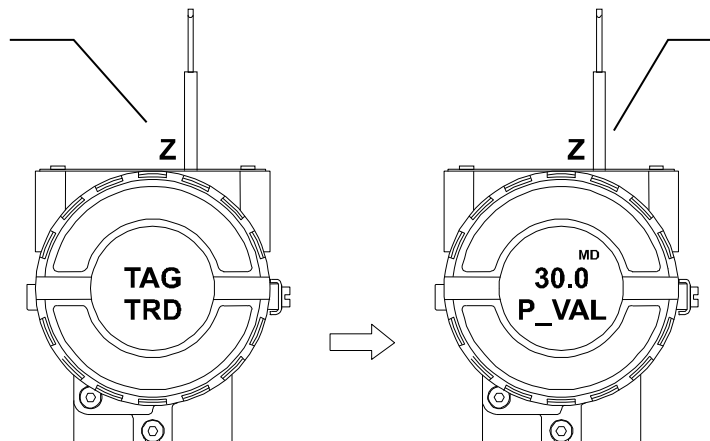

In this option the first variable (**P_VAL**) is showed with its respective value (if you want that it keep static, put the tool in **S** orifice and stay there).

Figure 3.20 - Step 3 - TT302

In order to configure the lower value (lower), simply insert the magnetic tool in orifice **S** as soon as LOWER is shown on the display. An arrow pointing upward (↑) increments the valve and an arrow pointing downward (↓) decrements the value. In order to increment the value, keep the tool insert in **S** up to set the value desired.

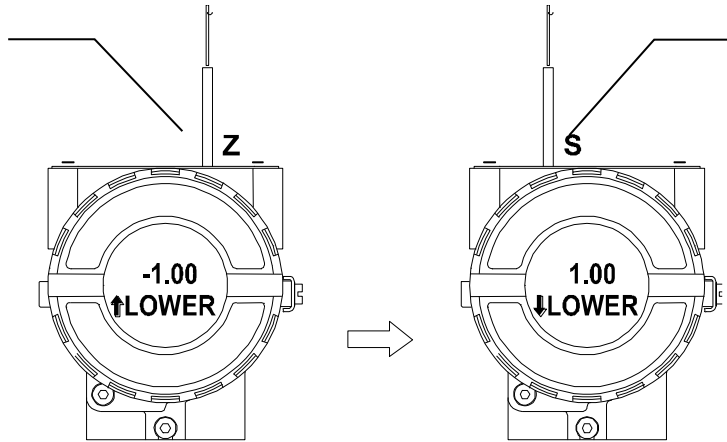

In order to decrement the lower value, insert the magnetic tool in orifice **Z** to shift the arrow to the downward position. After this, lift it from orifice **S**, and insert it in the orifice **S**, and wait to achieve the desired value.

Figure 3.21 - Step 4 - TT302

In order to range the upper value (upper), simply insert the magnetic tool in orifice **S** as soon as upper is shown on the display. An arrow pointing upward (↑) increment the value and an arrow pointing downward (↓) decrements the value. In order to increment the value, keep the tool insert in **S** up to set the value desired.

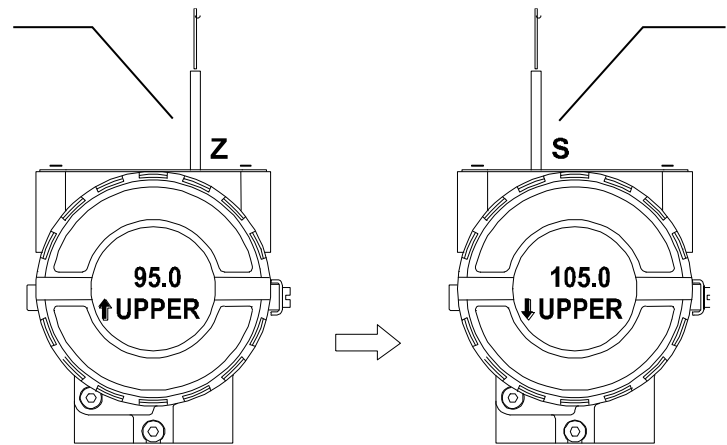

In order to decrement the upper value, insert the magnetic tool in orifice **Z** to shift the arrow to the downward position. After this, insert it in the orifice **S**, and wait to achieve the desired value.

Figure 3.22 - Step 5 - TT302

In order to configure the connection (**CONN**), simply insert the magnet tool in orifice **S** as soon as **CONN** is shown on the display. An arrow pointing upward (↑) increment the value and an arrow pointing downward (↓) decrement the value. The number over **CONN** mnemonic is the value corresponding of the table 3.2. See it to do the correct choice of the connection value.

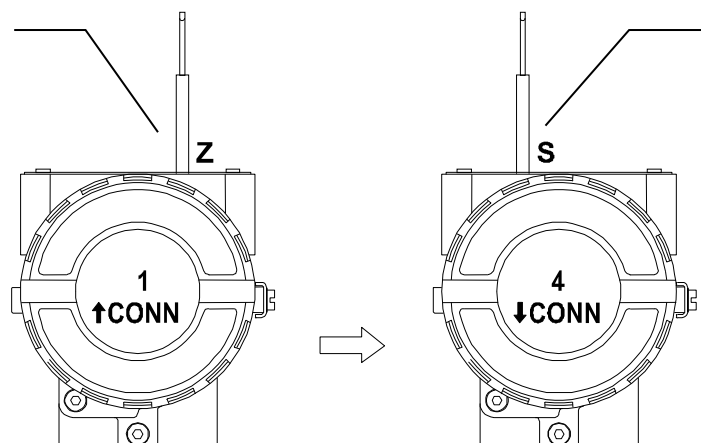

In order to decrement the connection value, insert the magnetic tool in orifice **Z** to shift the arrow to the downward position. After this, insert it in the orifice **S**, and wait to achieve the desired value.

Figure 3.23 - Step 6 - TT302

In order to configure the connection (TYPE), simply insert the magnet tool in orifice **S** as soon as **TYPE** is shown on the display. An arrow pointing upward (↑) increment the value and an arrow pointing downward (↓) decrement the value. The number over **TYPE** is the value corresponding of the table 3.1. See it to do the correct choice of the connection value.

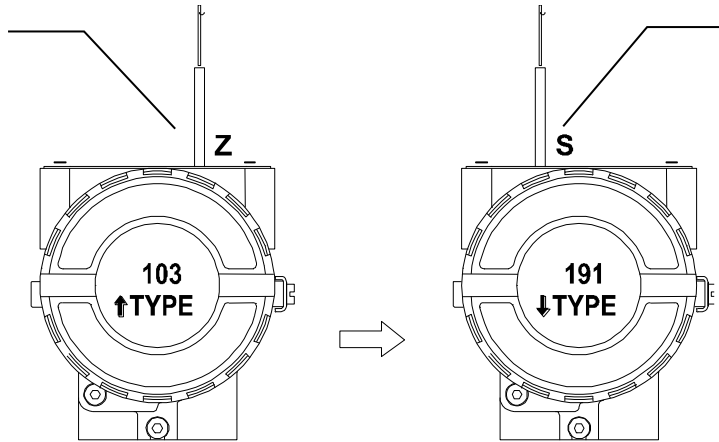

In order to decrement the connection type value, place the magnetic tool in orifice **Z** to shift the arrow to the downward position. After this, insert it in the orifice **S**, and wait to achieve the desired value.

Figure 3.24 - Step 7 - TT302

Section 4

MAINTENANCE PROCEDURES

Troubleshooting

SMAR TT302 transmitters are extensively tested and inspected before delivery to the end user. Nevertheless, during their design and development, consideration was given to the possibility of repairs being made by the end user, if necessary.

In general, it is recommended that end users do not try to repair printed circuit boards. Spare circuit boards may be ordered from **SMAR** whenever necessary.

SYMPTOM	PROBABLE SOURCE OF PROBLEM
<p style="text-align: center;">NO COMMUNICATION</p>	<ul style="list-style-type: none"> ▪ Transmitter Connections Check wiring polarity and continuity. Check for shorts or ground loops. Check if the power supply connector is connected to main board. Check if the shield is not used as a conductor. It should be grounded at one end only.
	<ul style="list-style-type: none"> ▪ Power Supply Check power supply output. The voltage must be between 9 - 32 VDC at the TT302 terminals. Noise and ripple should be within the following limits: a) 16 mV peak to peak from 7.8 to 39 KHz. b) 2 V peak to peak from 47 to 63 Hz for non-intrinsic safety applications and 0.2 V for intrinsic safety applications. c) 1.6 V peak to peak from 3.9 MHz to 125 MHz.
	<ul style="list-style-type: none"> ▪ Network Connection Check that the topology is correct and all devices are connected in parallel. Check that two Terminators are OK and correctly positioned. Check that the Terminators are according to the specifications. Check length of trunk and spurs. Check spacing between couplers.
	<ul style="list-style-type: none"> ▪ Network Configuration Make sure the device tag is configured if system configuration is desired. Make sure that device address, connection and index for all variables are configured correctly if pre-configuration is used.
	<ul style="list-style-type: none"> ▪ Electronic Circuit Failure Check the main board for defect by replacing it with a spare one.
<p style="text-align: center;">NCORRECT READING</p>	<ul style="list-style-type: none"> ▪ Transmitter Connections Check for intermittent short circuits, open circuits and grounding problems. Check if the sensor is correctly connected to the TT302 terminal block. Check if the sensor signal is reaching the TT302 terminal block by measuring it with a multimeter at the transmitter end.
	<ul style="list-style-type: none"> ▪ Noise, Oscillation Adjust damping Check grounding of the transmitters housing, extra important for mV and thermocouple input. Check the terminal block for moisture. Check that the shielding of the wires between sensor/ transmitter and transmitter/ panel is grounded only in one end.
	<ul style="list-style-type: none"> ▪ Sensor Check the sensor operation; it shall be within its characteristics. Check sensor type; it shall be the type and standard that the TT302 has been configured to. Check if process is within the range of the sensor and the TT302.
	<ul style="list-style-type: none"> ▪ Electronic Circuit Failure Check the integrity of circuit replacing it with a spare one.
	<ul style="list-style-type: none"> ▪ Transmitter Configuration Check if the sensor and wires configuration are correct.

Table 4.1 - Messages of Errors and Potential Cause

If the problem is not presented in the table above follow the Note below:

NOTE

The Factory Init should be tried as a last option to recover the equipment control when the equipment presents some problem related to the function blocks or the communication. **This operation must only be carried out by authorized technical personnel and with the process offline, since the equipment will be configured with standard and factory data.**

This procedure resets all the configurations run on the equipment, after which a partial download should be performed. With exception to the equipment physical address and the gsd identifier number selector parameter. After doing this, all configurations must be remade according to their applications.

To run the factory Init, use two magnetic screwdrivers. Remove the screw on the equipment that fixes the identification tag on the carcass top to access the orifices bearing the letters "S" and "Z".

The operations to follow are:

- 1) Turn off the equipment; insert the magnetic tools in each orifice (S and Z). Leave them in the orifices;
- 2) Power the equipment;
- 3) As soon as Factory Init is shown on the display, take off the tools and wait for the "5" symbol on the right upper corner of the display to unlit, thus indicating the end of the operation.

This operation has factory configuration that eliminates possible problems with the functional blocks or the transmitter communication.

Caution: this operation must be carried out by an authorized technician, with the process offline, as the process will be configured with factory standard data.

Disassembly Procedure

Refer to Figure 4.2 - Exploded View. Make sure to disconnect the power supply before disassembling the transmitter.

Sensor

If the sensor is mounted on the transmitter, first disconnect the wires in order to prevent the wires from breaking. To access the terminal block, first loosen the cover locking screw on the side marked "Field Terminals", then unscrew the cover.

Electronic Circuits

The main board (5) and input board (7) are matched pairs and must be changed together and not mixed with others. To remove the circuit boards (5 and 7) and the display (4), first loosen the cover locking (8) on the side not marked "Field Terminals" then unscrew the cover (1).

Loosen the two screws (3) that anchor the display and the main circuit board. Gently pull out the display, and then the main board (5). To remove the input board (7), first unscrew the two screws (6) that anchors it to the housing (9), gently pull out the board.

WARNING

The boards have CMOS components, which may be damaged by electrostatic discharges. Observe correct procedures for handling CMOS components. It is also recommended to store the circuit boards in electrostatic-proof cases.

Reassembly Procedure

- Put input board (7) into housing (9).
- Anchor input board with its screws (6).
- Put main board (5) into the housing, ensuring all inter connecting pins are connected.
- Put display (4) into the housing, observing the four mounting positions (See Figure 4.1) " _ " should point in the direction desired as UP.
- Anchors main board and display with their screws (3).
- Fit the cover (1) and lock it using the locking screw (8).

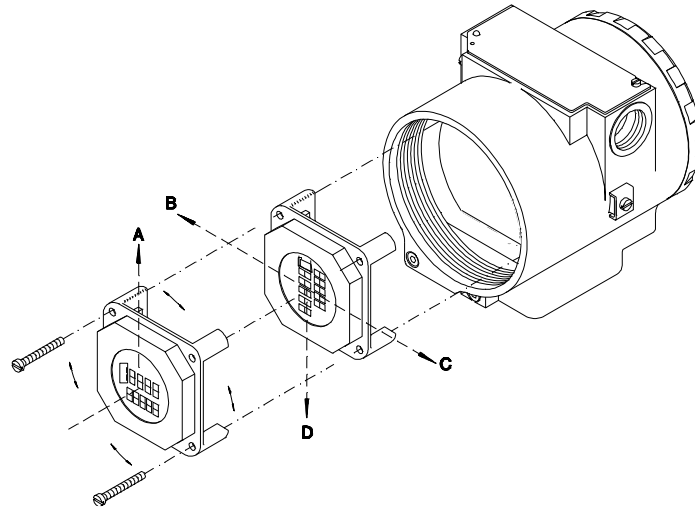

Figure 4.1 - Four Possible Positions of the Display

Interchangeability

The Main and Input boards must be kept together because of the calibration data that is stored in the main board EEPROM. In the case of one board being faulty, both must be replaced.

Returning Materials

Should it become necessary to return the transmitter to SMAR, simply contact your local agent or SMAR office, informing the defective instrument's serial number, and return it to our factory.

In order to expedite analysis and solution of the problem, the defective item should be returned with a description of the failure observed, with as many details as possible. For faster problem evaluation, the material sent must describe the installation data, type of measure adopted and process conditions.

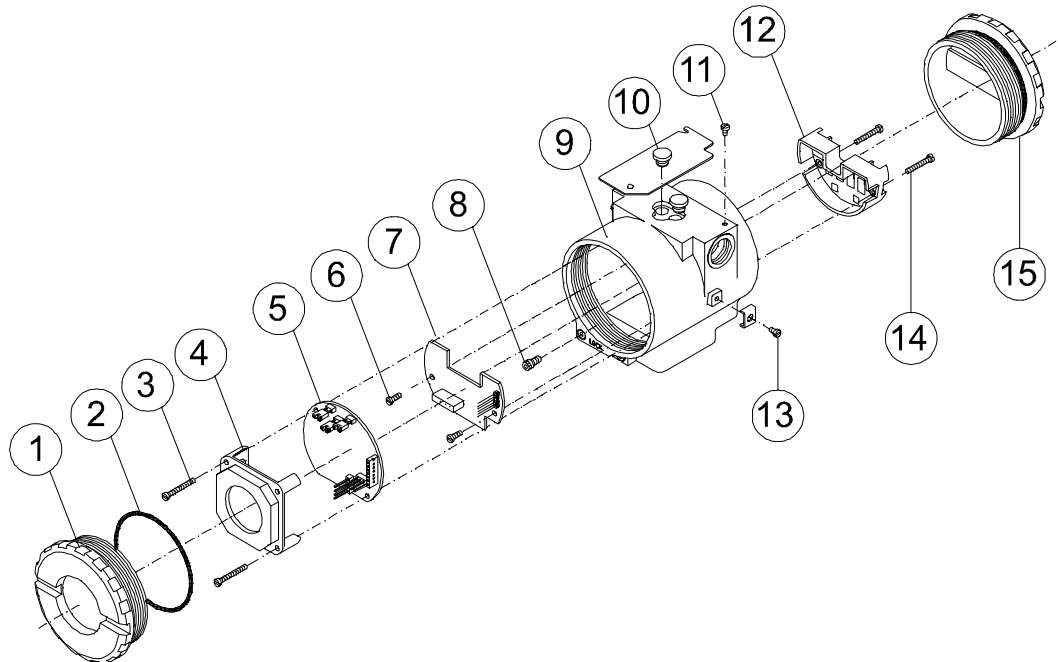

Figure 4.2 - Exploded View

NOTE

For aluminium housing there is an insert in the position 13. This insert is used to improve the grounding.

ACCESSORIES	
ORDERING CODE	DESCRIPTION
SD1	Magnetic Tool for Local Adjustment
SYSCON	System Configurator
PS302	Power Supply
BT302	Terminator
DFI302	Fieldbus Universal Bridge

Table 4.2 - Accessories of SYSTEM 302

SPARE PARTS LIST			
DESCRIPTION OF PARTS	POSITION	CODE	CATEGORY (NOTA 1)
HOUSING, Aluminum (NOTE 2)			
. 1/2 - 14 NPT	9	314-0130	
. M20 x 1.5	9	314-0131	
. PG 13.5 DIN	9	314-0132	
HOUSING, 316 SS (NOTE 2)			
. 1/2 - 14 NPT	9	314-0133	
. M20 x 1.5	9	314-0134	
. PG 13.5 DIN	9	314-0135	
COVER (INCLUDES O'RING)			
. Aluminum	1 and 15	204-0102	
. 316 SS	1 and 15	204-0105	
COVER WITH WINDOW FOR INDICATION (INCLUDES O'RING)			
. Aluminum	1	204-0103	
. 316 SS	1	204-0106	
COVER LOCKING SCREW	8	204-0120	
EXTERNAL GROUND SCREW	13	204-0124	
IDENTIFICATION PLATE FIXING SCREW	11	204-0116	
DIGITAL INDICATOR	4	214-0108	
TERMINAL INSULATOR	12	314-0123	
MAIN INPUT CIRCUIT BOARD ASSEMBLY	5 and 7	400-0234	A
O'RINGS (NOTE 3)			
. Cover, Buna-N	2	204-0122	B
TERMINAL HOLDING SCREW.			
. Housing in Aluminum	14	304-0119	
. Housing in 316 Stainless Steel	14	204-0119	
MAIN BOARD SCREW HOUSING IN ALUMINUM			
. Units with indicator	3	304-0118	
. Units without indicator	3	304-0117	
MAIN BOARD SCREW HOUSING IN 316 STAINLESS STEEL			
. Units with indicator	3	204-0118	
. Units without indicator	3	204-0117	
INPUT BOARD SCREW			
. Housing in Aluminum	6	314-0125	

SPARE PARTS LIST			
DESCRIPTION OF PARTS	POSITION	CODE	CATEGORY (NOTA 1)
. Housing in 316 Stainless Steel	6	214-0125	
MOUNTING BRACKET FOR 2" PIPE MOUNTING (NOTE 4)			
. Carbon Steel	-	214-0801	
. Stainless Steel 316	-	214-0802	
. Carbon Steel bolts, nuts, washers and U-clamp in Stainless Steel	-	214-0803	
LOCAL ADJUSTMENT PROTECTION CAP	10	204-0114	

Table 4.3 - Spare Part List

NOTE
<ol style="list-style-type: none"> 1. For category A, it is recommended to keep, in stock, 25 parts installed for each set, and for category B, 50. 2. It includes Terminal holder insulator, bolts (cover lock, grounding and terminal holder insulator) and identification plate without certification. 3. O-Rings are packaged in packs of 12 units. 4. Including U-clamp, nuts, bolts and washers.

Section 5

TECHNICAL CHARACTERISTIC

Functional Specifications	
Inputs	See table 5.1, 5.2, 5.3 and 5.4
Output and Communication Protocol	Digital only. Complies with IEC 61158-2: 2000 (H1): 31.25 kbit/s voltage mode, bus powered.
Power Supply / Current Consumption	Bus powered: 9 - 32 Vdc. Quiescent current consumption: 12 mA.
Indicator	4 1/2 -digit numerical and 5-character alphanumeric LCD indicator (optional).
Hazardous Area Certifications	Intrinsic Safety (FM, CSA, EXAM, CEPEL, NEPSI), Explosion Proof (FM, CSA, NEMKO, CEPEL), Dust Ignition Proof (FM), Non-incendive (FM), FISCO (FM, CSA, NEMKO, EXAM, CEPEL, NEPSI) and FNICO (FM, CSA, NEMKO, EXAM, CEPEL)
European Directive Information	Authorized representative in European Community Smar GmbH-Rheingaustrasse 9-55545 Bad Kreuznach ATEX Directive (94/9/EC) –Equipment and protective systems intended for use in potentially explosive atmospheres This product was certified according European Standards at NEMKO and EXAM (former DMT). The certified body for manufacturing quality assessment is EXAM (number 0158). LVD Directive 2006/95/EC – Electrical Equipment designed for use within certain voltage limits According the LVD directive Annex II the equipment under ATEX “Electrical equipment for use in an explosive atmosphere” directive are excluded from scope from this directive.
Zero and Span Adjustments	No interactive, via local adjustment and digital communication.
Failure Alarm (Diagnostics)	For sensor or circuit failures, status is sent to link outputs. Detailed diagnostics are available in the contained parameters.
Temperature Limits	Operation: -40 °C to 85 °C (-40 to 185 °F) Storage: -40 °C to 120 °C (-40 to 248 °F) Display: -20 °C to 80 °C (-4 to 176 °F) -40 °C to 85 °C (-40 to 185 °F) (without damage)
Turn-on Time	Performs within specifications in less than 10 seconds after power is applied to the transmitter.
Configuration	Basic configuration may be done using the local adjustment magnetic tool if device is fitted with display. Complete configuration is possible using configuration tools such as Syscon302 (System Configuration Tool), AMS™, FieldCare™ and HHT375.
Humidity Limits	0 to 100% RH

Performance Specifications	
Accuracy	See table 5.1, 5.2, 5.3 and 5.4
Temperature Effect	For a 10 °C variation: mV (-6 to 22 mV), TC (NBS: B, R, S,T): ± 0.03% of the input millivoltage or 0.002 mV whichever is greater; mV (-10 to 100 mV), TC (NBS: E, J, K, N; DIN: L, U): ± 0.03% of the input millivoltage or 0.01 mV whichever is greater; mV (-50 to 500 mV): ± 0.03% of the input millivoltage or 0.05 mV whichever is greater; Ohms (0 to 100Ω), RTD (GE: Cu10): ± 0.03% of the input resistance or 0.01Ω whichever is greater; Ohms (0 to 400Ω), RTD (DIN: Ni120; IEC: Pt50, Pt100; JIS: Pt50, Pt100): ± 0.03% of the input resistance or 0.04Ω whichever is greater; Ohms (0 to 2000Ω), RTD (IEC: Pt500): ± 0.03% of the input resistance or 0.2Ω whichever is greater; TC: cold-junction compensation rejection 60:1 (Reference: 25.0 ± 0.3 °C).
Power Supply Effect	± 0.005% of calibrated span per volt

Performance Specifications	
Electrical Connection	1/2 - 14 NPT M20 X 1.5 PG 13.5 DIN 1/2 - 14 NPT X 3/4 NPT (AI 316) - with adapter 1/2 - 14 NPT X 3/4 BSP (AI 316) - with adapter 1/2 - 14 NPT X 1/2 BSP (AI 316) - with adapter
Mounting	Can be attached directly to the sensor. With an optional bracket can be installed on a 2" pipe or fixed on a wall or panel.

Note: Explosion proof approvals do not apply to adapter, only to transmitter.

Physical Specifications	
Approximate Weights	Without display and mounting bracket: 0.80 kg Add for digital display: 0.13 kg Add for mounting bracket: 0.60 kg
Control Functions Characteristics (Optional)	RES, TRD, DSP, DIAG, AI, PID, EPID, ARTH, INTG, ISEL, CHAR, SPLT, AALM, SPG, TIME, LLAG, OSLD and CT

SENSOR	2, 3 or 4 wires				
	TYPE	RANGE °C	RANGE °F	MINIMUM SPAN °C	°C DIGITAL ACCURACY*
RTD	Cu10 GE	-20 to 250	-4 to 482	50	± 1.0
	Ni120 DIN	-50 to 270	-58 to 518	5	± 0.1
	Pt50 IEC	-200 to 850	-328 to 1562	10	± 0.25
	Pt100 IEC	-200 to 850	-328 to 1562	10	± 0.2
	Pt500 IEC	-200 to 450	-328 to 842	10	± 0.2
	Pt1000 IEC	-200 to 300	-328 to 572	10	± 0.2
	Pt50 JIS	-200 to 600	-328 to 1112	10	± 0.25
	Pt100 JIS	-200 to 600	-328 to 1112	10	± 0.25
THERMOCOUPLE	B NBS	100 to 1800	212 to 3272	50	± 0.5**
	E NBS	-100 to 1000	-148 to 1832	20	± 0.2
	J NBS	-150 to 750	-238 to 1382	30	± 0.3
	K NBS	-200 to 1350	-328 to 2462	60	± 0.6
	N NBS	-100 to 1300	-148 to 2372	50	± 0.5
	R NBS	0 to 1750	32 to 3182	40	± 0.4
	S NBS	0 to 1750	32 to 3182	40	± 0.4
	T NBS	-200 to 400	-328 to 752	15	± 0.15
	L DIN	-200 to 900	-328 to 1652	35	± 0.35
U DIN	-200 to 600	-328 to 1112	50	± 0.5	

Table 5.1 - 2, 3 or 4 wires Sensor Characteristics

* Accuracy of value read on display and accessed by communication. The 4-20 mA accuracy is the digital accuracy ±0.03%

** Not applicable for the first 20% of the range (up to 440 °C).

SENSOR	DIFFERENTIAL				
	TYPE	RANGE °C	RANGE °F	MINIMUM SPAN °C	°C DIGITAL ACCURACY*
RTD	Cu10 GE	-270 to 270	-486 to 486	50	± 2.0
	Ni120 DIN	-320 to 320	-576 to 576	5	± 0.5
	Pt50 IEC	-1050 to 1050	-1890 to 1890	10	± 1.0
	Pt100 IEC	-1050 to 1050	-1890 to 1890	10	± 1.0
	Pt500 IEC	NA	NA	NA	NA
	Pt1000 IEC	NA	NA	NA	NA
	Pt50 JIS	-800 to 800	-1440 to 1440	10	± 1.0
	Pt100 JIS	-800 to 800	-1440 to 1440	10	± 1.5
THERMOCOUPLE	B NBS	-1700 to 1700	-3060 to 3060	60	± 1.0**
	E NBS	-1100 to 1100	-1980 to 1980	20	± 1.0
	J NBS	-900 to 900	-1620 to 1620	30	± 0.6
	K NBS	-1550 to 1550	-2790 to 2790	60	± 1.2
	N NBS	-1400 to 1400	-2520 to 2520	50	± 1.0
	R NBS	-1750 to 1750	-3150 to 3150	40	± 2.0
	S NBS	-1750 to 1750	-3150 to 3150	40	± 2.0
	T NBS	-600 to 600	-1080 to 1080	15	± 0.8
	L DIN	-1100 to 1100	-1980 to 1980	35	± 0.7
U DIN	-800 to 800	-1440 to 1440	50	± 2.5	

Table 5.2 - Differential Sensor Characteristics

* Accuracy of value read on display and accessed by communication.

** Not applicable for the first 20% of the range (up to 440 °C).

SENSOR	RANGE mV	*DIGITAL ACCURACY %
mV	-6 to 22	± 0.02% or ± 2 µV
	-10 to 100	± 0.02% or ± 10 µV
	-50 to 500	± 0.02% or ± 50 µV
mV DIF.	-28 to 28	± 0.1% or ± 10 µV
	-110 to 110	± 0.1% or ± 50 µV

Table 5.3 - mV Sensor Characteristics

SENSOR	RANGE Ohm	*DIGITAL ACCURACY %
Ohm	0 to 100	± 0.02% or ± 0.01 Ohm
	0 to 400	± 0.02% or ± 0.04 Ohm
	0 to 2000	± 0.02% or ± 0.20 Ohm
Ohm DIF.	-100 to 100	± 0.08% or ± 0.04 Ohm
	-400 to 400	± 0.1% or ± 0.2 Ohm

Table 5.4 - Ohm Sensor Characteristics

* Accuracy of value read on display and accessed by communication.

** Not applicable for the first 20% of the range (up to 440 °C).

NA Not applicable.

Ordering Code

MODEL										TEMPERATURE TRANSMITTER											
COD.		Local Indicator																			
0		Without Indicator								1		With Digital Indicator									
COD.		Mounting Bracket																			
0		Without Bracket								2		316 SST Bracket		A		Flat, 304 SST bracket and 316 SST accessories					
1		Carbon Steel Bracket								7		Carbon Steel Bracket with 316 SST Fasteners									
COD.		Electrical Connections																			
0		1/2 - 14 NPT (3)								3		1/2 - 14 NPT x 1/2 BSP (316 SST) - With adapter (2)		Z		According to user's notes					
1		1/2 - 14 NPT x 3/4 NPT (316 SST) - With adapter (4)								A		M20 x 1.5 (5)									
2		1/2 - 14 NPT x 3/4 BSP (316 SST) - With adapter (2)								B		PG 13.5 DIN (5)									
COD.		Housing Material (7) (8)																			
H0		Aluminum (IP/TYPEx)								H3		316 SST for use in saline atmosphere (IPW/TYPEx) (9)									
H1		316 SST (IP/TYPEx)								H4		Copper Free Aluminum Aluminum (IPW/TYPEx) (9)									
H2		Aluminum for use in saline atmosphere (IP/TYPEx) (9)																			
COD.		Identification Plate																			
I1		FM: XP, IS, NI, DI		I4		EXAM (DMT): Ex-ia, NEMKO: Ex-d		I6		Without Certification		IE		NEPSI: Ex-ia							
I3		CSA: XP, IS, NI, DI		I5		CEPEL: Ex-d, Ex-ia		I7		EXAM (DMT): Group I, M1 Ex-ia											
COD.		Tag Plate (6)																			
J0		With tag, when specified (Default)								J2		According to user's notes									
J1		Blank																			
COD.		Sensor Connection																			
L2		2-wire								LF		Differential									
L3		3-wire								LD		Double 2-wire									
L4		4-wire								LB		Backup									
COD.		Painting																			
P0		Gray Munsell N 6,5 Polyester (Default)								P5		Yellow Polyester		PC		Safety Blue Polyester -					
P3		Black Polyester								P8		Without Painting		Electrostatic Painting							
P4		White Epoxy								P9		Safety Blue Epoxy – Electrostatic Painting									
COD.		Sensor Type																			
T1		Cu10 - GE								TA		Thermocouple type B - NBS		TP		Thermocouple type U - DIN					
T2		Ni120 - DIN								TB		Thermocouple type E - NBS		TN		100 OHM					
T3		PT50 - IEC								TC		Thermocouple type J - NBS		TQ		22 mV					
T4		PT100 - IEC								TD		Thermocouple type K - NBS		TR		100 mV					
T5		PT500 - IEC								TE		Thermocouple type N - NBS		TS		500 mV					
T6		PT50 - JIS								TF		Thermocouple type R - NBS									
T7		PT100 - JIS								TG		Thermocouple type S - NBS									
T8		2K OHM								TH		Thermocouple type T - NBS									
T9		400 OHM								TK		Thermocouple type L - DIN									

TT302	1	2	0	H1	I1	JO	L2	P8	T1
-------	---	---	---	----	----	----	----	----	----

NOTE

- (1) Values limited to 4 1/2 digits; units limited to 5 characters.
- (2) Not certified for use in hazardous locations.
- (3) Certified for use in hazardous locations (CEPEL, CSA, FM, NEPSI, NEMKO, EXAM).
- (4) Certified for use in hazardous locations (CEPEL, CSA).
- (5) Certified for use in hazardous locations (CEPEL, NEPSI, NEMKO, EXAM).
- (6) Rectangular plate in 316 SST.
- (7) IPX8 tested in 10 meters of water column for 24 hours.
- (8) Ingress Protection:

Product	CEPEL	NEMKO / EXAM	FM	CSA	NEPSI
TT300	IP66/68W	IP66/68W	Type 4X/6(6P)	Type 4X	IP67

- (9) IPW/TYPEx testes for 200 hours according to NBR 8094 / ASTM B 117 standard.

CERTIFICATIONS INFORMATION

European Directive Information

Consult www.Smar.com for the EC declarations of conformity and certificates.

Authorized representative/importer located within the Community:

Smar Europe BV De Oude Wereld 116 2408 TM Alphen aan den Rijn Netherlands

ATEX Directive 2014/34/EU - "Equipment for explosive atmospheres" (applicable from 20 April 2016)

The EC-Type Examination Certificate is released by DNV GL Presafe AS (CE2460) and DEKRA EXAM GmbH (CE0158).

Designated certification body that monitors manufacturing and released QAN (Quality Assurance Notification) and QAR (Quality Assessment Report) is Nemko AS (CE0470).

LVD Directive 2014/35/EU – "Low Voltage" (applicable from 20 April 2016)

According to the LVD directive Annex II, electrical equipment for use in an explosive atmosphere is outside the scope of this directive.

According to IEC standard: IEC 61010-1:2010 - Safety requirements for electrical equipment for measurement, control, and laboratory use - Part 1: General requirements.

ROHS Directive 2011/65/EU - "Restriction of the use of certain hazardous substances in electrical and electronic equipment"

For the evaluation of the products the following standards were consulted: EN 50581:2012

EMC Directive 2014/30/EU - "Electromagnetic Compatibility" (applicable from 20 April 2016)

For products evaluation the standard IEC 61326-1:2013 were consulted and to comply with the EMC directive the installation must follow these special conditions:

Use shielded, twisted-pair cable for powering the instrument and signal wiring.

Keep the shield insulated at the instrument side, connecting the other one to the ground.

Hazardous locations general information

Ex Standards:

IEC 60079-0 General Requirements

IEC 60079-1 Flameproof Enclosures "d"

IEC 60079-7 Increased Safe "e"

IEC 60079-11 Intrinsic Safety "i"

IEC 60079-18 Encapsulation "m"

IEC 60079-26 Equipment with equipment protection level (EPL) Ga

IEC 60079-31 Equipment dust ignition protection by enclosure "t"

IEC 60529 Classification of degrees of protection provided by enclosures (IP Code)

IEC 60079-10 Classification of Hazardous Areas

IEC 60079-14 Electrical installation design, selection and erection

IEC 60079-17 Electrical Installations, Inspections and Maintenance

IEC 60079-19 Equipment repair, overhaul and reclamation

ISO/IEC80079-34 Application of quality systems for equipment manufacture

Warning:

Explosions could result in death or serious injury, besides financial damage.

Installation of this instrument in hazardous areas must be in accordance with the local standards and type of protection. Before proceedings with installation make sure that the certificate parameters are in accordance with the classified hazardous area.

Maintenance and Repair

The instrument modification or replaced parts supplied by any other supplier than authorized representative of Smar is prohibited and will void the Certification.

Marking Label

The instrument is marked with type of protection options. The certification is valid only when the type of protection is indicated by the user. Once a particular type of protection is installed, do not reinstall it using any other type of protection.

Intrinsic Safety / Non Incendive application

In hazardous areas with intrinsic safety or or non-incendive requirements, the circuit entity parameters and applicable installation procedures must be observed.

The instrument must be connected to a proper intrinsic safety barrier. Check the intrinsically safe parameters involving the barrier and equipment including the cable and connections. Associated apparatus ground bus shall be insulated from panels and mounting enclosures. Shield is optional, when using shielded cable, be sure to insulate the end not grounded.

Cable capacitance and inductance plus C_i and L_i must be smaller than C_o and L_o of the Associated Apparatus.

It is recommended do not remove the housing covers when powered on.

Explosionproof / Flameproof application

Only use Explosionproof/Flameproof certified Plugs, Adapters and Cable glands.

The electrical connections entries must be connected using a conduit with sealed unit or closed using metal cable gland or metal blanking plug with at least IP66.

Do not remove the housing covers when powered on.

Enclosure

The electronic housing and sensor threads installed in hazardous areas must have a minimum of 6 fully engaged threads.

The covers must be tightening with at least 8 turns, to avoid the penetration of humidity or corrosive gases, and until it touches the housing. Then, tighten more 1/3 turn (120°) to guarantee the sealing.

Lock the housing and covers using the locking screw.

Degree of Protection of enclosure (IP)

IPx8: Second numeral meaning continuous immersion in water under special condition defined as 10m for a period of 24 hours (Ref: IEC60529).

IPW/ TypeX: Supplementary letter W or X meaning special condition defined as saline environment tested in saturated solution of NaCl 5% w/w at 35°C for a period of 200 hours (Ref: NEMA 250/ IEC60529).

For enclosure with IP/IPW/TypeX applications, all NPT threads must apply a proper water-proof sealant (a non-hardening silicone group sealant is recommended).

Hazardous Locations Approvals

FM Approvals (Factory Mutual)

Intrinsic Safety (FM 4Y3A4.AX)

IS Class I, Division 1, Groups A, B, C and D

IS Class II, Division 1, Groups E, F and G

IS Class III, Division 1

Explosion Proof (FM 4Y3A4.AX)

XP Class I, Division 1, Groups A, B, C and D

Dust Ignition Proof (FM 4Y3A4.AX)

DIP Class II, Division 1, Groups E, F and G

DIP Class III, Division 1

Non Incendive (FM 4Y3A4.AX)

NI Class I, Division 2, Groups A, B, C and D

Environmental Protection (FM 4Y3A4.AX)

Option: Type 4X/6/6P or Type 4/6/6P

Entity Parameters Fieldbus Power Supply Input (report 3015629):

$V_{max} = 24$ Vdc, $I_{max} = 250$ mA, $P_i = 1.2$ W, $C_i = 5$ nF, $L_i = 12$ uH

$V_{max} = 16$ Vdc, $I_{max} = 250$ mA, $P_i = 2$ W, $C_i = 5$ nF, $L_i = 12$ uH

Temperature Class: T4

Ambient Temperature: 60°C (-20 to 60 °C)

Drawing

102A-0079, 102A-1231, 102A-1354, 102A-1646, 102A-1647

DNV GL Presafe AS

Explosion Proof (PRESAFE 20 75160X)
 Group II, Category 2 G, Ex db, Group IIC, Temperature Class T6, EPL Gb
 Ambient Temperature: -20 °C to +60 °C
 Options: IP66W/68W or IP66/68

Special conditions for safe use:

Repairs of the flameproof joints must be made in compliance with the structural specifications provided by the manufacturer.

Repairs must not be made on the basis of values specified in tables 1 and 2 of EN/IEC 60079-1.

The Essential Health and Safety Requirements are assured by compliance with:

EN IEC 60079-0:2018 General Requirements

EN 60079-1:2014 Flameproof Enclosures “d”

Drawing

102A-1529, 102A-1473

DEKRA Testing and Certification GmbH

Intrinsic Safety (DMT 00ATEX E 061)

Group I, Category M2, Ex ia, Group I, EPL Mb

Group II, Category 2 G, Ex ia, Group IIC, Temperature Class T4/T5/T6, EPL Gb

FISCO Field Device

Supply circuit for the connection to an intrinsically safe FISCO fieldbus-circuit:

$U_i = 24$ Vdc, $I_i = 380$ mA, $P_i = 5.32$ W, $C_i \leq 5$ nF, $L_i = \text{Neg}$

Parameters of the supply circuit comply with FISCO model according to Annex G EN60079-11:2012, replacing EN 60079-27:2008.

2 wire/3 wire/4 wire measuring circuit in type of protection Ex ia I / II C for the connection to intrinsically safe thermocouples or resistance temperature indicators:

$U_o = 6.5$ Vdc, $I_o = 20$ mA, $P_o = 30$ mW, $C_i \leq 300$ nF, $L_i = \text{Neg}$, $C_o \leq 700$ nF, $L_i \leq 20$ mH

The 2 wire/3 wire/4 wire measuring circuit is galvanically separated from the fieldbus circuit.

Ambient Temperature:

$-40^\circ\text{C} \leq T_a \leq +60^\circ\text{C}$ (T4)

$-40^\circ\text{C} \leq T_a \leq +50^\circ\text{C}$ (T5)

$-40^\circ\text{C} \leq T_a \leq +40^\circ\text{C}$ (T6)

The Essential Health and Safety Requirements are assured by compliance with:

EN 60079-0:2012 + A11:2013 General Requirements



EN 60079-11:2012 Intrinsic Safety “i”

Drawing

102A-1473, 102A-1529, 102A-1475, 102A-1531

CEPEL (Centro de Pesquisa de Energia Elétrica)

Segurança Intrínseca (CEPEL 96.0076X)

 CEPEL 96.0076X Equipamento de campo FISCO Ex ia IIC T* Ga					 CEPEL 95.0076X Equipamento de campo FISCO Ex ia IIIC T* Da				
IP66W/IP68W		IP66/IP68			IP66W/IP68W		IP66/IP68		
(aço inox e alumínio Copper Free)		(alumínio)			(aço inox e alumínio Copper Free)		(alumínio)		
$U_i = 30$ V	$I_i = 380$ mA	$P_i = 5,32$ W	$C_i = 5,0$ nF	$L_i = \text{desp}$	$U_i = 30$ V	$I_i = 380$ mA	$P_i = 5,32$ W	$C_i = 5,0$ nF	$L_i = \text{desp}$
$T_{\text{amb}}: -20^\circ\text{C}$ a $+50^\circ\text{C}$ para T5 $T_{\text{amb}}: -20^\circ\text{C}$ a $+65^\circ\text{C}$ para T4					$T_{\text{amb}}: -20^\circ\text{C}$ a $+50^\circ\text{C}$ para T100 °C $T_{\text{amb}}: -20^\circ\text{C}$ a $+65^\circ\text{C}$ para T135 °C				

Prova de Explosão (CEPEL 97.0089)

 <p>CEPEL 97.0089 Ex db IIC T6 Gb Ex tb IIIC T85 °C Db</p>	
IP66W/IP68W	IP66/IP68
(aço inox e alumínio Copper Free)	(alumínio)
T _{amb} : -20 °C a +40 °C	

Observações:

- O número do certificado é finalizado pela letra "X" para indicar que para a versão do Transmissor de temperatura, intrinsecamente seguro, modelo TT302 equipado com invólucro fabricado em liga de alumínio, somente pode ser instalado em "Zona 0", se durante a instalação for excluído o risco de ocorrer impacto ou fricção entre o invólucro e peças de ferro/aço.
- O produto adicionalmente marcado com a letra suplementar "W" indica que o equipamento foi ensaiado em uma solução saturada a 5% de NaCl p/p, à 35 °C, pelo tempo de 200 h e foi aprovado para uso em atmosferas salinas, condicionado à utilização de acessórios de instalação no mesmo material do equipamento e de bujões de aço inoxidável ASTM-A240, para fechamento das entradas roscadas não utilizadas. Os materiais de fabricação dos equipamentos aprovados para letra "W" são: aço inoxidável AISI 316 e alumínio Copper Free SAE 336 pintados (Procedimento P-CQ-FAB764-09) com tinta Resina Poliéster ou Resina Epoxy com espessura da camada de tinta de 70 a 150 µm e 120 a 200 µm, respectivamente, ou pintados com o plano de pintura P1 e P2 (Procedimento P-CQ-FAB-765-05) com tinta Resina Epoxy ou Poliuretano Acrílico Alifático com espessura de camada de tinta de 290 µm a 405 µm e 185 µm a 258 µm, respectivamente.
- Os planos de pintura P1 e P2 são permitidos apenas para equipamento fornecido com plaqueta de identificação com marcação para grupo de gases IIB.
- O grau de proteção IP68 só é garantido se nas entradas roscadas de ½" NPT for utilizado vedante não endurecível à base de silicone conforme Procedimento P-DM-FAB277-06.
- O segundo numeral oito indica que o equipamento foi ensaiado para uma condição de submersão de dez metros por vinte e quatro horas. O acessório deve ser instalado em equipamentos com grau de proteção equivalente.
- As atividades de instalação, inspeção, manutenção, reparo, revisão e recuperação dos equipamentos são de responsabilidade dos usuários e devem ser executadas de acordo com os requisitos das normas técnicas vigentes e com as recomendações do fabricante.

Normas Aplicáveis:

- ABNT NBR IEC 60079-0:2013 Atmosferas explosivas - Parte 0: Equipamentos – Requisitos gerais
- ABNT NBR IEC 60079-1:2016 Atmosferas explosivas - Parte 1: Proteção de equipamento por invólucro à prova de explosão "d"
- ABNT NBR IEC 60079-11:2013 Atmosferas explosivas - Parte 11: Proteção de equipamento por segurança intrínseca "i"
- ABNT NBR IEC 60079-26:2016 Equipamentos elétricos para atmosferas explosivas - Parte 26: Equipamentos com nível de proteção de equipamento (EPL) Ga
- ABNT NBR IEC 60079-31:2014 Atmosferas explosivas - Parte 31: Proteção de equipamentos contra ignição de poeira por invólucros "t"
- ABNT NBR IEC 60529:2017 Graus de proteção para invólucros de equipamentos elétricos (Código IP)

Desenhos

102A1382	TT302 Plaqueta de identificação CEPEL IP66/68
102A1261	TT302 Plaqueta de identificação CEPEL IP66W/68W
102A2052	TT302 Plaqueta de identificação CEPEL IP66/68 IIB P1/P2
102A2051	TT302 Plaqueta de identificação CEPEL IP66W/68W IIB P1/P2
102A2101	TT302 Plaqueta de identificação CEPEL IP66 POEIRA

Identification Plate

FM Approvals (Factory Mutual)

smar TT302 Temperature Transmitter
BR - 14160
Made in Brazil

Temp. Class: T4	XP CL I, DIV 1, GP A,B,C,D.
Tamb. 60°C max.	DIP CL II,III, DIV 1, GP E,F,G.
Vmax. 24 VDC	S CL III, DIV 1.
I max. 250 mA	IS CL I,II,III, DIV 1, GP A,B,C,D,E,F,G.
Ci 5 nF	NI CL I, DIV 2, GP A,B,C,D.
Li 8 uH	Per inst. dwg 102A0079.

FM APPROVED Type 4X/6/6P

0044333 - 2007

CE 123100

smar TT302 Temperature Transmitter
BR - 14160
Made in Brazil

Temp. Class: T4	XP CL I, DIV 1, GP A,B,C,D.
Tamb. 60°C max.	DIP CL II,III, DIV 1, GP E,F,G.
Vmax. 24 VDC	S CL III, DIV 1.
I max. 250 mA	IS CL I,II,III, DIV 1, GP A,B,C,D,E,F,G.
Ci 5 nF	NI CL I, DIV 2, GP A,B,C,D.
Li 8 uH	Per inst. dwg 102A0079.

FM APPROVED Type 4X/6/6P

0044333 - 2007

CE 135400

smar TT302 Temperature Transmitter
TX - 77040
Made in USA

Temp. Class: T4	XP CL I, DIV 1, GP A,B,C,D.
Tamb. 60°C max.	DIP CL II,III, DIV 1, GP E,F,G.
Vmax. 24 VDC	S CL III, DIV 1.
I max. 250 mA	IS CL I,II,III, DIV 1, GP A,B,C,D,E,F,G.
Ci 5 nF	NI CL I, DIV 2, GP A,B,C,D.
Li 8 uH	Per inst. dwg 102A0079.

FM APPROVED Type 4/6/6P

0000000 - 0000

CE 164601

smar TT302 Temperature Transmitter
TX - 77040
Made in USA

Temp. Class: T4	XP CL I, DIV 1, GP A,B,C,D.
Tamb. 60°C max.	DIP CL II,III, DIV 1, GP E,F,G.
Vmax. 24 VDC	S CL III, DIV 1.
I max. 250 mA	IS CL I,II,III, DIV 1, GP A,B,C,D,E,F,G.
Ci 5 nF	NI CL I, DIV 2, GP A,B,C,D.
Li 8 uH	Per inst. dwg 102A0079.

FM APPROVED Type 4X/6/6P

0000000 - 0000

CE 164701

DNV GL Presafe AS / DEKRA Testing and Certification GmbH

smar TT302 Temperature Transmitter
Nova Smar S/A
Av. Dr. Antônio Furlan Jr
1028 Sertãozinho-SP
14170-480
Brazil

Ex II 2G Ex ia IIC T4/T5/T6 Gb DMT 00 ATEX E 061 ()
Pi = 5,32 W -40°C ≤ Ta ≤ +60°C
Ui = 24 VDC li = 380 mA Li = neg Ci ≤ 5 nF

IP66W
IP68W 10m/24h

Ex II 2G Ex db IIC T6 Gb PRESAFE 20 ATEX 75160X ()
Tamb = -20°C to 60°C U = 28 VDC

0000000 - 0000

CE 0470 152905

smar TT302 Temperature Transmitter
Nova Smar S/A
Av. Dr. Antônio Furlan Jr
1028 Sertãozinho-SP
14170-480
Brazil

Ex II 2G Ex ia IIC T4/T5/T6 Gb DMT 00 ATEX E 061 ()
Pi = 5,32 W -40°C ≤ Ta ≤ +60°C
Ui = 24 VDC li = 380 mA Li = neg Ci ≤ 5 nF

IP66
IP68 10m/24h

Ex II 2G Ex db IIC T6 Gb PRESAFE 20 ATEX 75160X ()
Tamb = -20°C to 60°C U = 28 VDC

0000000 - 0000

CE 0470 147305

smar TT302 Temperature Transmitter
BR - 14160
Sertãozinho
Brazil

Ex I M2 Ex ia I Mb DMT 00 ATEX E 061
-40°C ≤ Ta ≤ +60°C
Pi = 5,32 W
Ui = 24 VDC li = 380 mA Li = neg Ci ≤ 5 nF

IP 66
68

0000000 - 0000

CE 0470 147501

smar TT302 Temperature Transmitter
BR - 14160
Sertãozinho
Brazil

Ex I M2 Ex ia I Mb DMT 00 ATEX E 061
-40°C ≤ Ta ≤ +60°C
Pi = 5,32 W
Ui = 24 VDC li = 380 mA Li = neg Ci ≤ 5 nF

IP 66 W
68 W

0000000 - 0000

CE 0470 153101

CEPEL (Centro de Pesquisa de Energia Elétrica)

smar TT302 Transmissor de Temperatura
Nova Smar S/A
Av. Dr. Antônio Furlan Jr
1028 Sertãozinho-SP
14170-480
Brazil

FISCO Field Device - Ex ia IIC T4 Ga
FISCO Field Device - Ex ic IIC T4 Gc

Ex db IIC T6 Gb CEPEL 97.0089 ()
Ex ia IIC T4/T5 Ga CEPEL 97.0076 X ()
Tamb = -20° a 65°C (T4) -20° a 50°C (T5)
Ui = 30V li = 380mA Pi = 5,32W
Ci = 5nF Li = desp

Segurança
Eletrabras
Coel
INMETRO

IP 66
68

0000000 - 0000

CE 138203

smar TT302 Transmissor de Temperatura
Nova Smar S/A
Av. Dr. Antônio Furlan Jr
1028 Sertãozinho-SP
14170-480
Brazil

FISCO Field Device - Ex ia IIC T4 Ga
FISCO Field Device - Ex ic IIC T4 Gc

Ex db IIC T6 Gb CEPEL 97.0089 ()
Ex ia IIC T4/T5 Ga CEPEL 97.0076 X ()
Tamb = -20° a 65°C (T4) -20° a 50°C (T5)
Ui = 30V li = 380mA Pi = 5,32W
Ci = 5nF Li = desp

Segurança
Eletrabras
Coel
INMETRO

IP 66 W
68 W

0000000 - 0000

CE 126103

TT302 - Certification Information

smar TT302 Transmissor de Temperatura

Nova Smar S/A
Av. Dr. Antônio Furlan Jr
1028 Sertãozinho-SP
14170-480
Brazil

FISCO Field Device - Ex ia IIC T4 Ga
FISCO Field Device - Ex ic IIC T4 Gc



Ex db IIB T6 Gb CEPEL 97.0089 ()
Ex ia IIB T4/T5 Ga CEPEL 97.0076 X ()
Tamb= -20° a 65°C (T4) -20° a 50°C (T5)
Ui= 30V li= 380mA Pi= 5,32W
Ci= 5nF Li= desp

Segurança
Eletróbios
OCF 3007
INMETRO

IP 66W
68W

P1/P2
Pintura

0000000 - 0000

  **205101**

smar TT302 Transmissor de Temperatura

Nova Smar S/A
Av. Dr. Antônio Furlan Jr
1028 Sertãozinho-SP
14170-480
Brazil

FISCO Field Device - Ex ia IIC T4 Ga
FISCO Field Device - Ex ic IIC T4 Gc



Ex db IIB T6 Gb CEPEL 97.0089 ()
Ex ia IIB T4/T5 Ga CEPEL 97.0076 X ()
Tamb= -20° a 65°C (T4) -20° a 50°C (T5)
Ui= 30V li= 380mA Pi= 5,32W
Ci= 5nF Li= desp

Segurança
Eletróbios
OCF 3007
INMETRO

IP 66
68

P1/P2
Pintura

0000000 - 0000

  **205201**

smar TT302 Transmissor de Temperatura

Nova Smar S/A
Av. Dr. Antônio Furlan Jr
1028 Sertãozinho-SP
14170-480
Brazil



Ex tb IIIC T85°C Db CEPEL 97.0089 ()
Ex ia IIIC T135°C/T100°C Da CEPEL 96.0076 X ()

Tamb= -20° a 65°C (T135°C)
-20° a 50°C (T100°C)
Ui= 30V li= 380mA Pi= 5,32W
Ci= 5nF Li= desp

Segurança
Eletróbios
OCF 3007
INMETRO

IP 66
68

0000000 - 0000

  **210101**

FM Approvals (Factory Mutual)

NON HAZARDOUS OR DIVISION 2 AREA

SAFE AREA APPARATUS

UNSPECIFIED, EXCEPT THAT IT MUST NOT BE SUPPLIED FROM, NOR CONTAIN UNDER NORMAL OR ABNORMAL CONDITIONS, A SOURCE OF POTENTIAL IN RELATION TO EARTH IN EXCESS OF 250VAC OR 250VDC.

ASSOCIATED APPARATUS

OPTIONAL SHIELDING

FIELDBUS BARRIER

GROUND BUS

POWER SUPPLY

HAZARDOUS AREA

REQUIREMENTS:

- 1 - INSTALLATION MUST BE IN ACCORDANCE WITH THE NATIONAL ELECTRICAL CODE (ANSI/NFPA 70) AND ANSI/ISA-RP12.6
- 2 - TRANSMITTER SPECIFICATION MUST BE IN ACCORDANCE TO APPROVAL LISTING.
- 3 - ASSOCIATED APPARATUS GROUND BUS TO BE INSULATED FROM PANELS AND MOUNTING ENCLOSURES.
- 4 - WIRES: TWISTED PAIR, 22AWG OR LARGER.
- 5 - SHIELD IS OPTIONAL IF USED, BE SURE TO INSULATE THE END NOT GROUNDED.
- 6 - CABLE CAPACITANCE AND INDUCTANCE PLUS C_i AND L_i MUST BE SMALLER THAN C_a AND L_a OF THE ASSOCIATED APPARATUS.
- 7 - ONLY SIMPLE APPARATUS CAN BE CONNECTED TO THE SENSOR TERMINALS 1,2,3,4. SIMPLE APPARATUS IS A DEVICE THAT WILL NOT GENERATE OR STORE MORE THAN 1.2V, 0.1A, 25mW, OR 20µJ. EXAMPLES ARE SWITCHES, THERMOCOUPLES AND RESISTANCE TEMPERATURE DETECTORS.

ENTITY PARAMETERS FOR TEMPERATURE SENSOR TERMINALS:

V_t=8.25V I_t=85.3mA C_a=5.5µF L_a=4.8mH

INTRINSICALLY SAFE APPARATUS

ENTITY VALUES: C_i=5nF L_i=8µH

V_{max} ≤ 24V

I_{max} ≤ 250mA

CLASS I,II,III DIV.1, GROUPS A,B,C,D,E,F & G

MODELS TT302 AND TT303 - SERIES

TEMPERATURE TRANSMITTERS.

COMPONENTS CAN NOT BE SUBSTITUTED WITHOUT PREVIOUS MANUFACTURER APPROVAL.

APPROVAL CONTROLLED BY C.A.R.

6	MARCIAL 20/10/08	GRATON 20/10/08	ALT DE 0049/08	DRAWING	DESIGN	VERIFIED	APPROVED
5	MARCIAL 16/07/07	MISSAWA 16/07/07	ALT DE 0004/07	MELONI 24/03/95	M.MISSAWA 24/03/95	SINASTRE 24/03/95	PELUSO 24/03/95
4	MOACIR 05/05/03	CASSIOLATO 05/05/03	ALT DE 0043/03	CUSTOMER:			
3	MOACIR 08/02/00	CASSIOLATO 08/02/00	ALT DE 0015/00	EQUIPMENT: TT302/303			
REV.	DESIGN	APPROVED	AREA	CONTROL DRAWING			

APPROVED

ENTITY PARAMETERS FOR ASSOCIATED APPARATUS

CLASS I,II,III DIV.1

GROUPS A,B,C,D,E,F & G

C_a ≥ CABLE CAPACITANCE +5nF

L_a ≥ CABLE INDUCTANCE +8µH

option 1	V _{oc} ≤ 24V	I _{sc} ≤ 250mA	P _o ≤ 1.2W
option 2	V _{oc} ≤ 16V	I _{sc} ≤ 250mA	P _o ≤ 2W

Appendix B

		SRF – Service Request Form Pressure Transmitters				Proposal No.:	
Company:			Unit:		Invoice:		
COMMERCIAL CONTACT				TECHNICAL CONTACT			
Full Name:				Full Name:			
Function:				Function:			
Phone:		Extension:		Phone:		Extension:	
Fax:				Fax:			
Email:				Email:			
EQUIPMENT DATA							
Model:			Serial Number:		Sensor Number:		
PROCESS DATA							
Process Fluid:							
Calibration Range		Ambient Temperature (°F)		Process Temperature (°F)		Process Pressure	
Min.:	Max.:	Min.:	Max.:	Min.:	Max.:	Min.:	Max.:
Static Pressure		Vacuum					
Min.:	Max.:	Min.:	Max.:				
Normal Operation Time:				Failure Date:			
FAILURE DESCRIPTION (Please, describe the observed behavior, if it is repetitive, how it reproduces, etc.)							
OBSERVATIONS							
USER INFORMATION							
Company:							
Contact:			Title:		Section:		
Phone:		Extension:		E-mail:			
Date:				Signature:			
For warranty or non-warranty repair, please contact your representative. Further information about address and contacts can be found on www.smar.com/contactus.asp .							

SMAR WARRANTY CERTIFICATE

1. SMAR guarantees its products for a period of 24 (twenty four) months, starting on the day of issuance of the invoice. The guarantee is valid regardless of the day that the product was installed.
2. SMAR products are guaranteed against any defect originating from manufacturing, mounting, whether of a material or manpower nature, provided that the technical analysis reveals the existence of a quality failure liable to be classified under the meaning of the word, duly verified by the technical team within the warranty terms.
3. Exceptions are proven cases of inappropriate use, wrong handling or lack of basic maintenance compliant to the equipment manual provisions. SMAR does not guarantee any defect or damage caused by an uncontrolled situation, including but not limited to negligence, user imprudence or negligence, natural forces, wars or civil unrest, accidents, inadequate transportation or packaging due to the user's responsibility, defects caused by fire, theft or stray shipment, improper electric voltage or power source connection, electric surges, violations, modifications not described on the instructions manual, and/or if the serial number was altered or removed, substitution of parts, adjustments or repairs carried out by non-authorized personnel; inappropriate product use and/or application that cause corrosion, risks or deformation on the product, damages on parts or components, inadequate cleaning with incompatible chemical products, solvent and abrasive products incompatible with construction materials, chemical or electrolytic influences, parts and components susceptible to decay from regular use, use of equipment beyond operational limits (temperature, humidity, etc.) according to the instructions manual. In addition, this Warranty Certificate excludes expenses with transportation, freight, insurance, all of which are the customer's responsibility.
4. For warranty or non-warranty repair, please contact your representative.

Further information about address and contacts can be found on www.smar.com/contactus.asp

5. In cases needing technical assistance at the customer's facilities during the warranty period, the hours effectively worked will not be billed, although SMAR shall be reimbursed from the service technician's transportation, meals and lodging expenses, as well dismounting/mounting costs, if any.
6. The repair and/or substitution of defective parts do not extend, under any circumstance, the original warranty term, unless this extension is granted and communicated in writing by SMAR.
7. No Collaborator, Representative or any third party has the right, on SMAR's behalf, to grant warranty or assume some responsibility for SMAR products. If any warranty would be granted or assumed without SMAR's written consent, it will be declared void beforehand.
8. Cases of Extended Warranty acquisition must be negotiated with and documented by SMAR.
9. If necessary to return the equipment or product for repair or analysis, contact us.
See item 4.
10. In cases of repair or analysis, the customer must fill out the Revision Requisition Form (FSR) included in the instructions manual, which contains details on the failure observed on the field, the circumstances it occurred, in addition to information on the installation site and process conditions. Equipments and products excluded from the warranty clauses must be approved by the client prior to the service execution.
11. In cases of repairs, the client shall be responsible for the proper product packaging and SMAR will not cover any damage occurred in shipment.

12. Responsibility: Except for the above-mentioned general warranty conditions for SMAR products, SMAR will not assume any responsibility before the customer, without limitation, for damages, consequences, indemnity claims, loss of earnings, service expenses and other costs caused by the non-observation of the installation, operation and maintenance instructions included in SMAR manuals. Furthermore, the buyer also agrees to exempt the supplier for indemnity of damages (with exception to costs for repairs or the reposition of defective products above described) directly or indirectly caused by inadequate tests, application, operation or repair of SMAR products.
13. It is the customer's responsibility to clean and decontaminate products and accessories prior to shipping them for repair, and SMAR and its dealer reserve themselves the right to refuse the service in cases not compliant to those conditions. It is the customer's responsibility to tell SMAR and its dealer when the product was utilized in applications that contaminate the equipment with harmful products during its handling and repair. Any other damages, consequences, indemnity claims, expenses and other costs caused by the lack of decontamination will be attributed to the client. Kindly, fill out the Declaration of Decontamination prior to shipping products to SMAR or its dealers, which can be accessed at www.smar.com/doc/declarationofcontamination.pdf and include in the packaging.
14. This warranty certificate is valid only when accompanying the purchase invoice.