



## RHM 60

### Coriolis Mass Flow Meter With Uncompromising Performance

#### Features

- Standard pressure ratings up to 490 bar (7107 psi)
- Temperature ratings from -196 to 350 °C (-320 to 662 °F)
- Mass flow uncertainty down to 0.1%
- Density uncertainty down to 0.0025 kg/l
- Repeatability down to 0.05%
- Typical measuring ranges between 3000 and 60 kg/min
- Accurately measure low flow rates down to 45 kg/min
- Unique robust torsion driven oscillation system
- Rheonik **AnyPipeFit Commitment** brings you the possibility to get any custom process connection type and size for savings on installation costs. Compact design with minimal footprint
- Approved for use in hazardous areas
- Stainless steel case

#### Applications

- Plant Balance
- Terminal Transfer
- Asphalt/Bitumen and other High Temperature Fluids
- Viscous Fluids
- Reactor Charging
- Batching
- Barge, Ship, Rail Car and Truck Filling

#### Rheonik Sensor Benefits

- Torsion oscillator design assures a stable and drift free measurement with excellent signal to noise ratios
- Resilient to external noise and vibration
- Insensitive to pipe pressure changes
- Robust tube wall thickness provides increased operational safety in abrasive applications
- Corrosion resistant
- Long sensor life guaranteed due to low mechanical stresses in the meter mechanism
- No moving parts to wear or fail

## General Specification Overview

<b>Nominal Flow (<math>Q_{nom}</math>)*</b>	3000 kg/min (6614 lb/min)
<b>Minimum Flow (<math>Q_{min}</math>)*</b>	60 kg/min (132.3 lb/min)
<b>Operating Temperature</b>	Fluid from -196°C to 350°C (-320°F to 662°F), see options in Part Number Code Ambient from -50°C to 80°C (-58°F to 176°F), optional up to 210°C (410°F)
<b>Pressure Ratings</b>	Up to 490 bar / 7107 psi - dependent upon material
<b>Humidity Limits</b>	5 to 95% relative humidity, non-condensing at +60°C (+140°F)
<b>Electrical Connection</b>	Cable entry M25 x 1.5 (standard), M20 x 1.5, ½" NPT, ¾" NPT (optional) Max. cable length to remote RHE transmitter 30m / 98ft
<b>Sensor Enclosure Materials</b>	Stainless steel (standard), 316 stainless steel (optional) Epoxy coated aluminum terminal box (standard), 316 stainless steel terminal box (optional)
<b>Enclosure Type</b>	Protection class IP65 (standard); IP 66 / NEMA 4X (optional)
<b>Wetted Materials</b>	1.4571 (316Ti), 2.4602 (Alloy C22), 1.4410 (SuperDuplex) Additional/customer specific materials available upon request
<b>Process Connections</b>	Nearly any - <b>the RHEONIK AnyPipeFit Commitment</b> . Consult factory for types/sizes not listed in this data sheet
<b>Pressure Rating Compliance</b>	Europe – PED: Module A2, Module B3.2+C2. Others on request
<b>Certifications and Approvals</b>	ATEX / IECEx Approvals for zone 0, 1, 2 (suitably rated RHE transmitter required) North American Approvals for Class I, Div. 1, Groups ABCD (suitably rated RHE transmitter required) American Bureau of Shipping (ABS) Product Type Approval for use on marine vessels
<b>Documentation, Testing and Inspection</b>	All sensors are hydro tested, calibrated and supplied with a traceable calibration certificate. Customized calibration and testing services available
<b>Project Documentation and QA, Services</b>	Rheonik offers a full set of services for large and complex engineering projects. Typical services offered are, but not limited to: <ul style="list-style-type: none"> <li>• Certificates of origin and conformity, mill certificates</li> <li>• Data books including WPAR, WQS, NDT, test &amp; quality plans, functional testing, calibration procedures, customized packing, factory acceptance etc.</li> <li>• Start up and commissioning services on/offshore</li> </ul>
<b>Options</b>	Enclosure heating for high temperature applications Cleaning for oxygen service Full service painting to project specifications – consult factory

\* At  $Q_{nom}$  pressure drop across a parallel tube sensor will be approximately 1 bar (14 psi) for H<sub>2</sub>O. Sensors can be operated at higher flow rates but pressure drop will be higher. Maximum recommended velocity (liquid) through the sensor is 15 m/s. Beyond this point, cavitation may occur.  $Q_{min}$  is the recommended lowest flow rate. Sensors will measure flow rates lower than  $Q_{min}$ , but uncertainty may increase beyond 0.5% of rate.

These flow rate and pressure drop statements relate to standard pressure tube sensor versions. Models with higher pressure ratings have increased wall thickness and will have higher pressure drops and lower  $Q_{nom}$  values.

## Measurement Performance

### Standard Calibration

A	<b>0.5% Uncertainty</b> ±0.5% uncertainty between $Q_{nom}$ and $Q_{min}$
B	<b>0.2% Uncertainty</b> ±0.2% uncertainty between $Q_{nom}$ and $Q_{0.2}$

Higher pressure units may have lower  $Q_{nom}$  values due to reduced tube ID

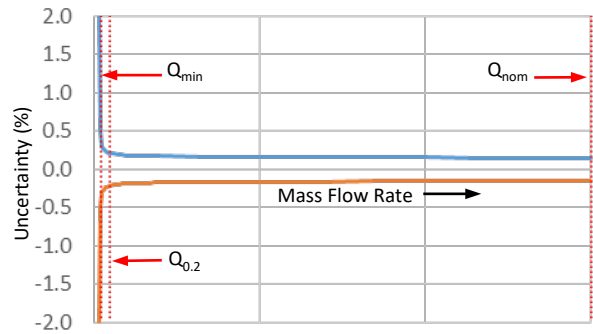

### Goldline Calibration

G	<b>0.1% Uncertainty</b> ±0.1% uncertainty between $Q_G$ and $(Q_G/10)$
---	---

Only for sensors with standard temperature and pressure range  
Customized calibration services are available – consult factory

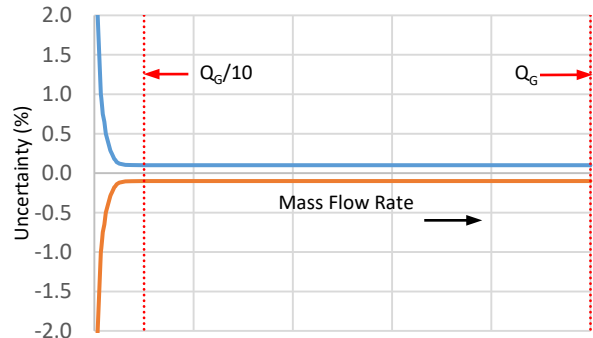

### Low Flow Calibration

2	<b>Low Flow Optimized Calibration</b> ±0.2% uncertainty between $(Q_{0.2} * 20)$ and $Q_{0.2}$ ±0.5% uncertainty between $Q_{0.2}$ and $Q_{min}$ ±0.6% uncertainty between $Q_{min}$ and $Q_{low}$
---	---

Only for sensors with standard temperature and pressure range

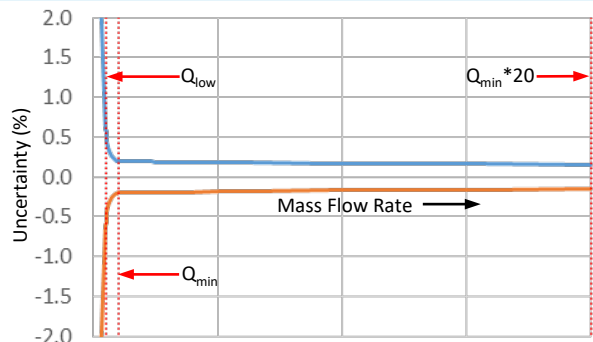

$Q_{nom}$	3000 kg/min (6614 lb/min)
$Q_{min}$	60 kg/min (132.3 lb/min)
$Q_G$	1800 kg/min (3968 lb/min)
$Q_{0.2}$	100 kg/min (220.5 lb/min)
$Q_{low}$	45 kg/min (99.2 lb/min)

Select the calibration option (A,B,G,2) required and include in the overall part number

### Density Calibration

N*	No Live Density Calibration
S	Standard +/- 0.005 kg/liter uncertainty between 500 and 1400 kg/m3
D	Enhanced +/- 0.0025 kg/liter uncertainty between 500 and 1400 kg/m3

For live volumetric flow, S or D calibration must be included in the part number and the sensor must be operated by an RHE with live density capability.

\* Even with No Live Density Calibration, volumetric flow can still be calculated with an inferred density value based upon a manually entered norm density value and its temperature gradient.

### Flow Measurement Repeatability

Standard ± 0.1% of rate  
Goldline ± 0.05% of rate

### Temperature Performance

Better than ±1°C

### Calibration Reference Conditions

Performance statements relate to the following conditions:

- Water (for mass flow accuracy)
- Temperature: 18 to 24°C (66 to 76°F)
- Pressure at 1 to 3 barg (15 to 45 psig)
- RHM with standard temperature, material and pressure range

## Measurement Tube Pressure Ratings

The maximum pressure ( $P_{max}$ ) of a sensor is determined by its lowest rated part. The lowest rated part can be either the measurement tube ( $P_{max}$  indicated below) or the process connection (for  $P_{max}$  see published standards or manufacturer information).

Pressure Code	Material Code	Material	Pmax					
			bar	psi	@	°C	°F	
P1 (std.)	M1 (std.)	1.4571 (316Ti) UNS S31635	104	1508	@	50	122	
			93	1349	@	120	248	
			80	1160	@	210	410	
			67	972	@	350	662	
	M3	2.4602 (Alloy C22) UNS N06022	138	2002	@	50	122	
			122	1769	@	120	248	
			104	1508	@	210	410	
			86	1247	@	350	662	
	62*	1.4462 (Duplex) UNS S31803	188	2727	@	50	122	
			165	2393	@	120	248	
			144	2089	@	210	410	
	10*	1.4410 (Super Duplex) UNS S32750	236	3423	@	50	122	
			207	3002	@	120	248	
			187	2712	@	210	410	
	P2	M1	1.4571 (316Ti) UNS S31635	206	2988	@	50	122
				184	2669	@	120	248
159				2306	@	210	410	
134				1944	@	350	662	
62*		1.4462 (Duplex) UNS S31803	270	3916	@	50	122	
			237	3437	@	120	248	
			207	3002	@	210	410	
10*		1.4410 (Super Duplex) UNS S32750	490	7107	@	50	122	
			430	6237	@	120	248	
			389	5642	@	210	410	
P3	M3	2.4602 (Alloy C22) UNS N06022	283	4105	@	50	122	
			250	3626	@	120	248	
			214	3104	@	210	410	
			178	2582	@	350	662	

\*Only with N1, NA, E2 temperature range (note Super Duplex min. temp. is -40°C) and seal-less construction type

## Other Materials and Pressure Ratings

Higher pressure rated measurement tubes in the materials above may be possible. Other wetted materials (e.g. Inconel, Monel, 304 stainless steel, others) are also possible for chemical compatibility, lower pressure drop, abrasion allowance and other application specific requirements.

Contact factory with specification for assessment and availability.

## Mechanical Construction

### Seal-less design

PFO: parallel/dual path

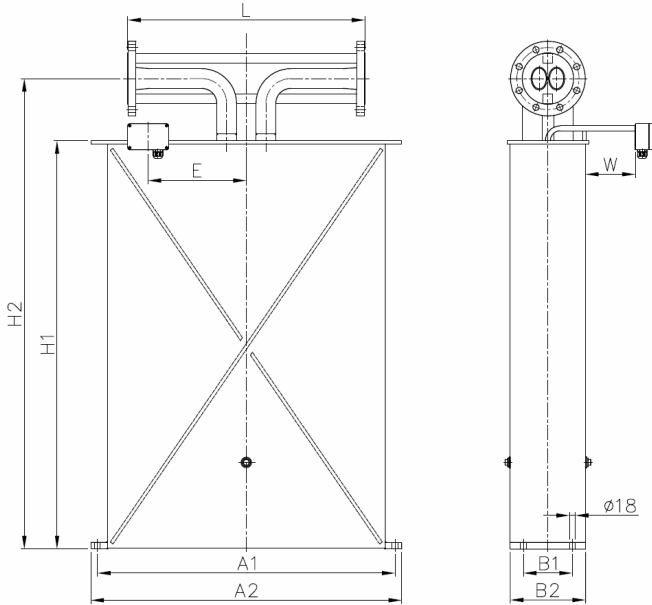

Process Connection	Dim. L	Dim. H2	Order Code
	mm / in	mm / in	
ANSI 4" 150#RF Flange	725 / 28.54	1443 / 56.81	F1
ANSI 4" 300#RF Flange	725 / 28.54	1443 / 56.81	F2
ANSI 4" 600#RF Flange	725 / 28.54	1443 / 56.81	F3
ANSI 4" 900#RTJ Flange	900 / 35.43	1443 / 56.81	R0
ANSI 4" 1500#RTJ Flange	900 / 35.43	1443 / 56.81	R2
ANSI 4" 2500#RTJ Flange	900 / 35.43	1443 / 56.81	R3
DIN DN100/PN16 Flange	725 / 28.54	1443 / 56.81	D4
DIN DN100/PN40 Flange	725 / 28.54	1443 / 56.81	C1
DIN DN100/PN100 Flange	725 / 28.54	1443 / 56.81	C2

1. C2 and F3 flange selection will reduce maximum allowable measurement tube pressure rating by a factor of 0.73

Dimensions	mm	in
A1	910	35.83
A2	950	37.40
B1	150	5.91
B2	230	9.06
H1	1253	49.33
E	300	11.81
W	150	5.91

**Standard blue terminal box in Aluminum, size = 125 x 80 x 57 mm (4.92 x 3.15 x 2.24 in)**  
- optionally available with integral RHE45 transmitter

Optional SS 316 box, size = 100 x 100 x 61 mm (3.94 x 3.94 x 2.40 in)  
- only for remote transmitter

**NOTE:** Junction boxes are supplied with M25 x 1.5 cable entries as standard. M20 x 1.5, ½" NPT, ¾" NPT cable entries are optionally available and must be ordered separately.

All dimensions are for standard products. For customization of face to face length and/or process connection types other than the ones listed on this page, please consult factory. Note that larger diameter flange process connections are always possible.

Net weight of RHM with standard flange ANSI 4" 150# approx. 235 kg (518 lb)  
Shipping box according to ISPM 15 dimensions approx. 180 x 120 x 75 cm (71 x 48 x 30 in)  
Gross weight with standard flanges and RHE28 transmitter approx. 310 kg (683 lb)

# RHM60 Part Number Code

**Temperature Range**

- N1 -20 to +120°C (-4 to +248°F) (std.)
- NA -50 to +120°C (-58 to +248°F)
- E2 -50 to +210°C (-58 to +410°F)
- E3 -196 to +50°C (-320 to +122°F)
- H4 0 to +350°C (+32 to +662°F)

**Pressure Code for Pmax of Measuring Loops (see pressure ratings page)**

- P1 pmax depends upon material
- P2 pmax depends upon material
- P3 pmax depends upon material

**Material of Wetted Parts**

- M1 1.4571 (316Ti) (std.)
- M3 2.4602 (Alloy C22), seal-less construction types only
- XX Other materials, e.g. (Super)Duplex are available upon request

**Process Connection**

See mechanical construction pages for available connections and codes

**Terminal Box Selection**

- JM Coated aluminum TB, M25 cable entry (options available)
- SM SS 316 TB, M25 cable entry (options available)
- TM No TB. 2m fixed / integral PTFE cable to RHE
- J5 Coated aluminum TB for integral RHE45, one or two M12 sockets

**Options Codes**

- NN No options
- See options listing for specific codes

**Hazardous Area Certifications**

- NN Without Ex Approval
- A0 ATEX/IEC Approval Zone 0: Ex II 1G Ex ia IIC T1-T6 Ga
- A1 ATEX/IEC Approval Zone 1: Ex II 2G Ex ia IIC T1-T6 Gb
- C0 CSA Approval USA-Canada Class I, Div. 1, Groups ABCD

**Pressure Design Compliance**

- NN No specific design compliance required
- A2 PED [Europe] module A2 - unless unstable gas
- BC PED [Europe] module B3.2+C2 - if A2 does not apply
- CA CRN [Canada] - Alberta province
- CR CRN [Canada] - all other provinces

**Mass Flow Calibration Selection**

See performance page for code options

**Density Calibration Selection**

See performance page for code options

**Additional Manufacturing Instructions**

- N No manufacturing instructions
- O Oil/grease free cleaning
- S Marine packing

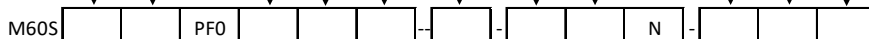

## Options and Accessories

RHM60 Part Number Option Codes	
H1	Hot oil/steam heating matrix for housing, DN25 PN40
H2	Hot oil/steam heating matrix for housing, 1" ANSI 150 RF
H3	Hot oil/steam heating matrix for housing, 1" ANSI 300 RF
P2	Housing purge connections - ½" NPT (2 pcs)
SB	Housing in 316 stainless steel
DY	Dye penetrant inspection
XR	X-ray test

NOTE: when specifying a sensor with multiple part code options (i.e. DY and XR), separate each code with a comma in the part string (i.e. ...DY,XR...)

Cable Entry Options (order separately)	
ORHM-E1	½" NPT Terminal Box Cable Entry
ORHM-E2	M20 x 1.5 Terminal Box Cable Entry
ORHM-E3	¾" NPT Terminal Box Cable Entry

Standard cable entry on terminal box is M25 x 1.5

## Transmitter Range



Any Rheonik Mass Flow Transmitter model can be combined with any Rheonik Mass Flow Sensor to provide an overall mass flow measurement system to suit any requirement. Rheonik Coriolis transmitters are available in versions specifically designed for process, industrial and OEM applications. Economical blind front versions of some transmitters are available where displays and keypads are not required. The wide range of sensors and transmitters provide tremendous options for system designers and end users alike.

## About Rheonik

Rheonik has but one single purpose: to design and manufacture the very best Coriolis meters available. Our research and engineering resources are dedicated to finding new and better ways to provide cost effective accurate mass flow solutions that provide value to our customers. Our manufacturing group care for each and every meter we produce from raw materials all the way to shipping, and our service and support group are available to help you specify, integrate, start-up and maintain every Rheonik meter you have in service. Whether you own just one meter or have hundreds, you will never be just another customer to us. You are our valued business partner.

Need a specific configuration for your plant? Don't compromise with a "standard" product from elsewhere that will add extra cost to your installation. If we can't configure it from our extensive and versatile product range, our exclusive **AnyPipeFit Commitment** can have your flow sensor customized with any size/type of process connection and face to face dimension you need.

No matter what control system you use as the backbone in your enterprise, with our **AnyInterface Commitment**, you can be sure that connection and communication will not be a problem. Alongside a wide variety of discrete analog and digital signal connections, we can also provide just about any network/bus interface available (for example: HART, Profibus, ProfiNet, Foundation Fieldbus, PowerLink, Ethernet) with our 40 Series family of transmitters. Rheonik 40 Series transmitters can connect to your system – no headache and no conversion needed.