

smar - RP400WH

INSTRUCTION, OPERATION AND MAINTENANCE

MANUAL

WirelessHART REPEATER



OCT / 13
RP400WH
VERSION 1





**Specifications and information are subject to change without notice.
Up-to-date address information is available on our website.**

web: www.smar.com/contactus.asp

NOTE

This Manual is compatible with versions 1.XX, where 1 indicates the software version and XX indicates the release. Therefore, the Manual is compatible with all releases of version 1.

Waiver of responsibility

The contents of this manual abides by the hardware and software used on the current equipment version. Eventually there may occur divergencies between this manual and the equipment. The information from this document are periodically reviewed and the necessary or identified corrections will be included in the following editions. Suggestions for their improvement are welcome.

Warning

For more objectivity and clarity, this manual does not contain all the detailed information on the product and, in addition, it does not cover every possible mounting, operation or maintenance cases.

Before installing and utilizing the equipment, check if the model of the acquired equipment complies with the technical requirements for the application. This checking is the user's responsibility.

If the user needs more information, or on the event of specific problems not specified or treated in this manual, the information should be sought from Smar. Furthermore, the user recognizes that the contents of this manual by no means modify past or present agreements, confirmation or judicial relationship, in whole or in part.

All of Smar's obligation result from the purchasing agreement signed between the parties, which includes the complete and sole valid warranty term. Contractual clauses related to the warranty are not limited nor extended by virtue of the technical information contained in this manual.

Only qualified personnel are allowed to participate in the activities of mounting, electrical connection, startup and maintenance of the equipment. Qualified personnel are understood to be the persons familiar with the mounting, electrical connection, startup and operation of the equipment or other similar apparatus that are technically fit for their work. Smar provides specific training to instruct and qualify such professionals. However, each country must comply with the local safety procedures, legal provisions and regulations for the mounting and operation of electrical installations, as well as with the laws and regulations on classified areas, such as intrinsic safety, explosion proof, increased safety and instrumented safety systems, among others.

The user is responsible for the incorrect or inadequate handling of equipments run with pneumatic or hydraulic pressure or, still, subject to corrosive, aggressive or combustible products, since their utilization may cause severe bodily harm and/or material damages.

The field equipment referred to in this manual, when acquired for classified or hazardous areas, has its certification void when having its parts replaced or interchanged without functional and approval tests by Smar or any of Smar authorized dealers, which are the competent companies for certifying that the equipment in its entirety meets the applicable standards and regulations. The same is true when converting the equipment of a communication protocol to another. In this case, it is necessary sending the equipment to Smar or any of its authorized dealer. Moreover, the certificates are different and the user is responsible for their correct use.

Always respect the instructions provided in the Manual. Smar is not responsible for any losses and/or damages resulting from the inadequate use of its equipments. It is the user's responsibility to know and apply the safety practices in his country.

TABLE OF CONTENTS

INTRODUCTION	V
WIRELESSHART TECHNOLOGY OVERVIEW.....	V
PLANNING A WIRELESSHART NETWORK	VI
RP400 WIRELESSHART	XI
SECTION 01 - INSTALLATION	1.1
GENERAL.....	1.1
INSTALLATION PROCEDURE	1.1
ANTENNA ROTATION.....	1.4
HOUSING ROTATION	1.5
MAINTENANCE PORT.....	1.6
INSTALLATION IN HAZARDOUS AREAS.....	1.7
INTRINSICALLY SAFE.....	1.7
SECTION 02 - OPERATION	2.1
FUNCTIONAL DESCRIPTION - CIRCUIT	2.1
DISPLAY.....	2.2
LOCAL ADJUSTMENT.....	2.3
WRITE PROTECTION.....	2.4
SECTION 03 - MAINTENANCE	3.1
GENERAL.....	3.1
DIAGNOSTIC WITH DISPLAY	3.1
DISASSEMBLY PROCEDURE	3.1
ASSEMBLY PROCEDURE	3.3
TROUBLESHOOTING.....	3.5
ACCESSORIES AND SPARE PARTS.....	3.5
RETURNING MATERIALS.....	3.6
SECTION 04 - TECHNICAL CHARACTERISTICS	4.1
ORDERING CODE	4.2
SPECIAL OPTIONS	4.2
APPENDIX A – SRF – SERVICE REQUEST FORM	A.1
APPENDIX B - BATTERY SAFETY DATASHEET	B.1

INTRODUCTION

WirelessHART Technology Overview

The *WirelessHART* technology is based on a wireless mesh network communication protocol used in process automation applications. It adds wireless capabilities to the HART protocol, while maintaining compatibility with existing HART devices, commands and already known and used tools.

WirelessHART network

Basically, a *WirelessHART* network, defined in the HART specifications, consists of a host, a *WirelessHART* Gateway and one or more field devices and/or *WirelessHART* adapters. Together they compose a mesh network where the host and devices can communicate.

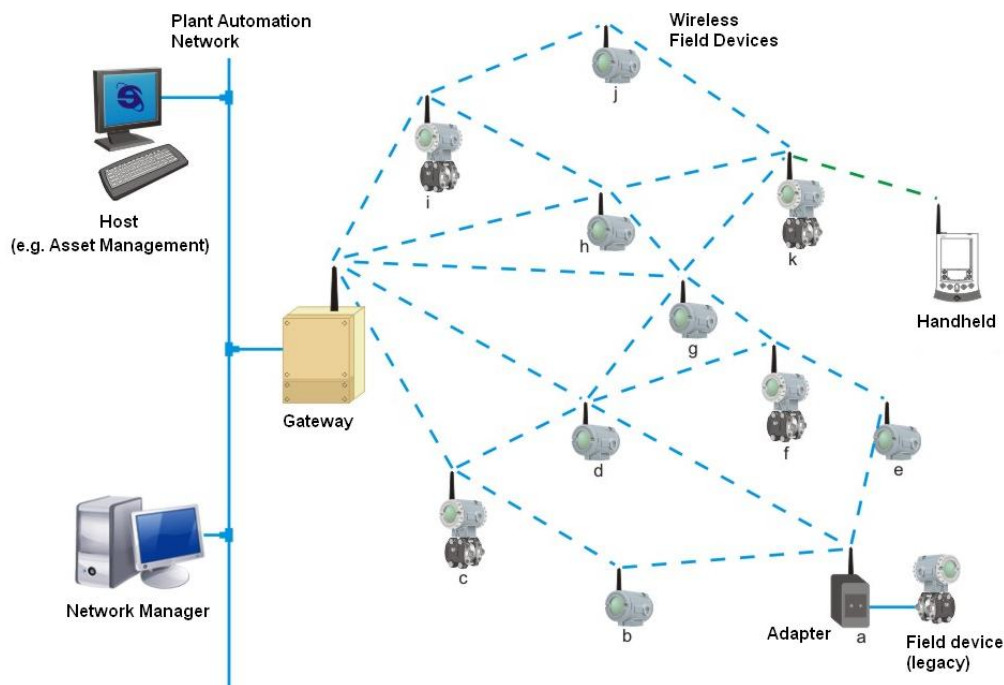

Host

The host, usually connected to the control network, is a workstation in which, e.g., can be installed a Human Machine Interface application, which allows an operator to interact with the process. Through the *WirelessHART* Gateway (DF100), the host can gather data from devices connected to the *WirelessHART* network. The host communicates with the *WirelessHART* Gateway (DF100) using a communication protocol, for example, HSE, H1, Profibus or Modbus.

WirelessHART Gateway (DF100)

It is a "translator" equipment. Thus it converts data from the host to the *WirelessHART* protocol, used by the devices connected to the *WirelessHART* network, and converts data from the devices to the host. In general, the *WirelessHART* Gateway (DF100) incorporates the features of Network Manager and Access Point. Roughly, the access point can be understood as the *WirelessHART* radio installed at the gateway to communicate with devices connected to the wireless network.

Security Manager

The Security Manager is an application usually embedded in the *WirelessHART* Gateway (DF100). Allowed only one Network Manager in a *WirelessHART* network, but the same Security Manager can serve several *WirelessHART* networks.

Its main function is to create, store and manage security keys (encryption and authentication) for which the devices have network access and monitor the status of network security.

Network Manager

The Network Manager is an application that can be embedded in the *WirelessHART* Gateway. On a *WirelessHART* network is only allowed to have one Network Manager. Among its responsibilities, the Network Manager distributes network identity (advertisement) publishing its existence, manages and authenticates the addition (joining) of devices to the network. It also distributes individual security keys (static or rotating) to the devices to ensure secure communication between it and the devices. The Network Manager assigns communication band to the devices already connected to the network that requested services to it, as well as manages the routes between the devices on the mesh network.

Specifically about the joining process of a *WirelessHART* device to the network, the Network Manager validates the Network ID and the Join Key attributes which are configured in the *WirelessHART* Gateway and *WirelessHART* devices.

The Network ID identifies a *WirelessHART* network in unique way. It is an **unsigned integer** attribute and must be configured on the *WirelessHART* Gateway and all *WirelessHART* devices. Considering a *WirelessHART* network installed in a plant, the permitted values for the Network ID ranges from 0 (hex 0x0000) to 32767 (0x7FFF hexadecimal).

The Join Key is a security key used to encrypt joining requests from *WirelessHART* devices that receive the advertisement with the Network Id identical to theirs. It may be single or each *WirelessHART* device may be configured with an individual Join Key. In the first case, the *WirelessHART* Gateway and all *WirelessHART* devices must be configured with the same Join Key. In the second case, which provides higher communication security level, (a) must be configured in the *WirelessHART* Gateway a list with individual Join Keys, i.e., a key for each *WirelessHART* device, and (b) you must configure each *WirelessHART* device with its individual Join Key. The Join Key is a hexadecimal string of 16 bytes. There is no restriction to the hexadecimal value of each byte. The table below shows examples of some join keys.

JOIN KEYS	16-BYTE HEXADECIMAL STRING
00000000000000000000000000000000	0x00, 0x00, 0x00, 0x00, 0x00, 0x00, 0x00, 0x00, 0x00, 0x00, 0x00, 0x00, 0x00, 0x00, 0x00, 0x00
000000000000000000000000000000302	0x00, 0x00, 0x00, 0x00, 0x00, 0x00, 0x00, 0x00, 0x00, 0x00, 0x00, 0x00, 0x03, 0x02, 0x00, 0x00
00000000FFFFFFFF0000000000000000	0x00, 0x00, 0x00, 0x00, 0x00, 0xFF, 0xFF, 0xFF, 0xFF, 0x00, 0x00, 0x00, 0x00, 0x00, 0x00, 0x00
550000000000000000000000000000AA	0x55, 0x00, 0x00, 0x00, 0x00, 0x00, 0x00, 0x00, 0x00, 0x00, 0x00, 0x00, 0x00, 0x00, 0x00, 0xAA

WirelessHART device

The *WirelessHART* field device is the device that connects to the process, being able to receive and/or transmit data on the *WirelessHART* network. It is a *WirelessHART* router (repeater) by nature, i.e., it is able to retransmit messages to/from other devices on the *WirelessHART* network.

WirelessHART Adapter

It is a bridge-type device, because it is able to provide data of HART + 4 to 20mA field device, legacy, to the host via *WirelessHART*. The adapter uses HART FSK standard communication, wired, to access data from HART field devices. And the adapter also uses the *WirelessHART* communication to provide data of the field device to the host. The adapter thus enables a HART field device to work on *WirelessHART* network.

Planning a WirelessHART network

The planning of a *WirelessHART* network is a task that is very similar to the activities that currently we perform with conventional wired devices. Furthermore, due to the simplicity of a mesh *WirelessHART* network, is exempt, in general, detailed field surveys, which are usually needed when we plan networks based on other wireless technologies.

Basically, a *WirelessHART* network involves planning, design, installation and commissioning phases.

Planning

This phase requires the execution of the following steps:

Scope definition

Clearly define the scope of the network. Answer the question: why do we need the wireless network? To monitor process variables or to implement a non-critical control? The answer to this question will facilitate the understanding between the team members responsible for the network and determine one or more process units in the plant. For each process unit, allocate a gateway with unique and specific Network ID. Outline the main field devices.

Identify potential sources of interference

Are there radio communications or other wireless networks in the plant? What protocols and frequencies do they use? Use high power? Although unlikely, given the robustness of the radios used by the *WirelessHART* technology, prior knowledge of the answers to these questions may identify potential sources of interference and to indicate the taking of preventive and/or limiting actions even before installation. For example, you can select a frequency channel as unavailable, adding it to the black list of frequencies that is under the *WirelessHART* Network Manager control.

Integration with the host

The gateway connects the *WirelessHART* field devices to the host system. Plan what devices and what data are needed. Also, the stations or applications which will process the data have to be clearly defined. From this set, among the protocols in the system, define which one will be used for integration with the host and with the existing tools for configuring the devices. After defining the protocol for integration, the user has to choose the gateway on the market that best meets your requirements. Smar offers the Gateway DF100 that supports Modbus/TCP/HSE.

Project

In the project phase, it is recommended the adoption of the practices below. Although conservative, these practices ensure robustness and scalability to the network.

- Define the Network ID that will be used for all devices in the process unit;
- Define if the Join Key will be common to all devices or individual and dedicated ;
- Define the policy to be used for the definition of devices (Long) Tags;
- Use a scale drawing of the process unit;
- Place the gateway in a strategic position in the process unit ;
- Plan networks with at least five devices;
- Install at least five devices within the gateway coverage area;
- Ensure that 25 % of the devices are within the gateway coverage area;

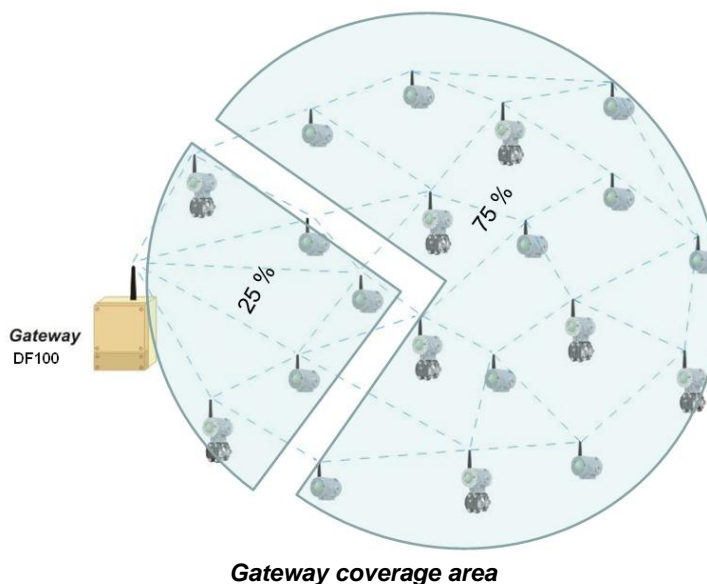

- Reposition the gateway as needed ;
- Check the coverage area of each device;
- Ensure that each device has three neighbors within its coverage area;

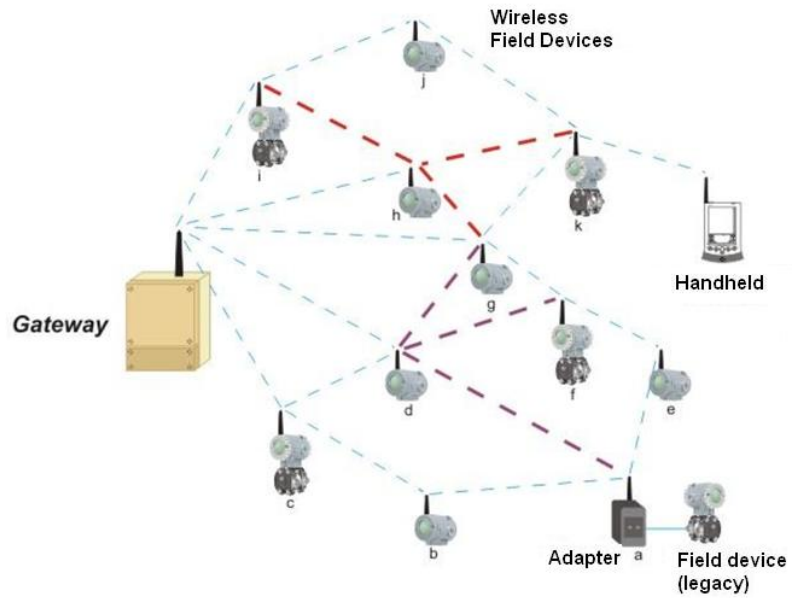

WirelessHART devices vicinity

- o Place the repeaters as needed.

Installation

As mentioned before, *WirelessHART* devices should be connected to the process and configured the same way as conventional wired HART devices. Handheld terminals can be used normally. Just be sure of having it properly uploaded with the latest DD files of the devices. However, it is known that the *WirelessHART* devices have characteristics inherent to the technology. Because of this, it is recommended the adoption of practices mentioned below for positioning the gateway and devices.

- o Install the gateway and the devices so that their antennas are vertical;
- o Ensure that the antennas are at 0.5 m minimum distance of large obstacles or surfaces ;
- o Ensure that the antennas of gateway and repeaters are 2 m above most obstacles within their coverage areas;

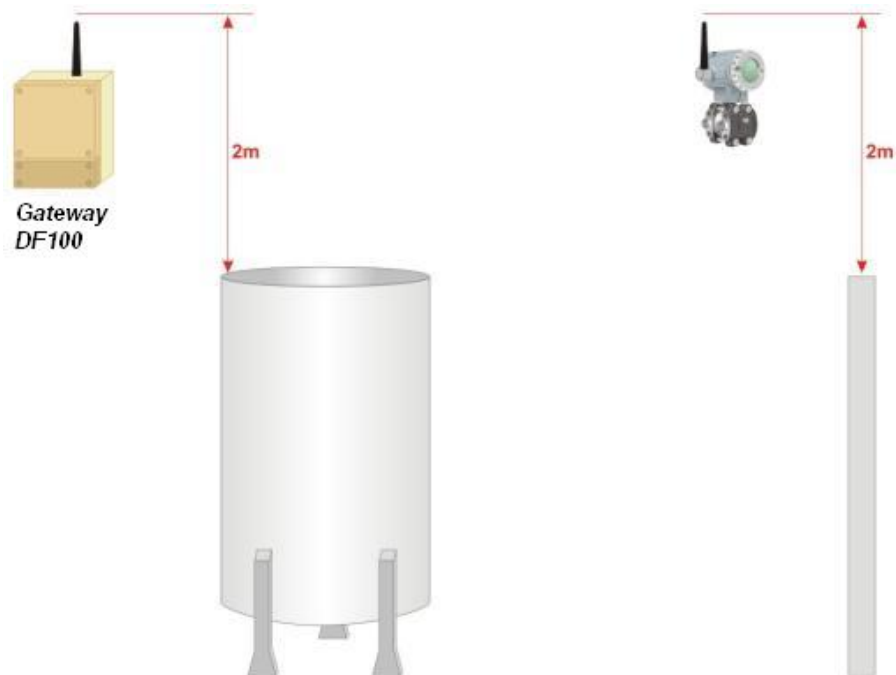

Gateway and repeater 2m above the obstacles

- o If there are high devices, does not exceed 45° viewing angles between them;

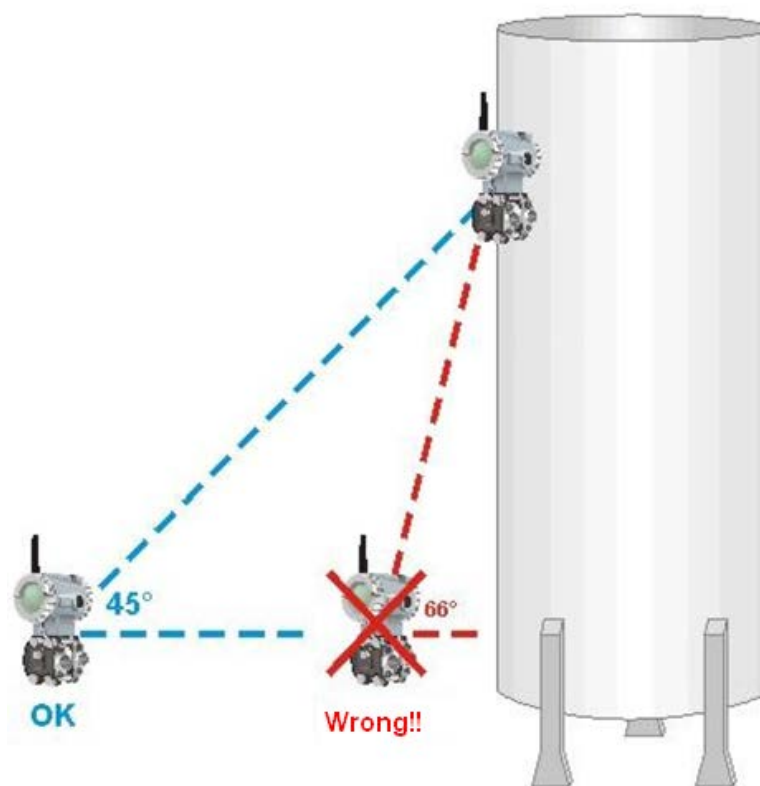

Device's viewing angle

- o Make sure that the gateway is integrated to the host system as planned.

Commissioning on Bench

Commissioning consists on testing the device and verifying its configuration data. The RP400 *WirelessHART* can be commissioned either before or after installation. The commissioning of the device in bench before its installation using CONF401, HPC401 or any DD-based configurator, e.g. Smar AssetView, ensures that all transmitters' components are working properly.

To turn on/off the repeater use the terminal SW1 (ON/OFF), as shown in Figure 1.7.

To connect the handheld to the device, use the communication terminals "CN1 and CN2" on the terminal block. See Figure 1.7.

Commission the devices and gateway.

WirelessHART devices commissioning

- Install and power the gateway (DF100)
- If not specified by the client at time of order, the Network ID and Join Key values of gateway and devices will be the factory default values. Note: It is strongly recommended that both be changed! To change these parameters install the gateway and all network devices following the steps below. Once the network is fully operational it will be more practical to change them.
- The devices configuration must be done individually, starting with those nearest to the gateway and further to the most distant so that communication is established correctly.
- Always install the device with the antenna in the vertical direction. None *WirelessHART* device must be located at the highest point of the plant, preventing it to work as possible lightning rod;
- Turn on the device by the switch at left of the display and wait for its connection to the network (this time can vary from 2 to 20 minutes depending on the network size). The device status on the network

can be verified on display, maintenance port or gateway.

ATTENTION

If the device was not purchased with the gateway, i.e. the gateway already has values of Network ID and Join Key different from the default values, it is necessary to set these parameters in the device so that it properly connects to the network: first configure Network ID and then Join Key, restarting the device after settings.

f. Once these steps are performed for all network devices and they are connected properly, it is time to change the values of Network ID and Join Key from factory following the instructions at the end of step "e" (if not changed yet). Network ID can be any number between 0 and 32767 which identifies the network among others. Join Key is a key of 32 hexadecimal characters (0-9 and AF) that works as a key so the devices can have access to the configured network.

g. Configure the LongTAG parameter that identifies the device on the network.

h. Check if the device engineering units are in accordance with those required by the process.

i. Configure the parameters of the burst mode to publish measurements and status desired:

Burst Message: up to 3 messages with commands and different times can be configured;

- Minimum Time : is the time for publication of the variables;
- Maximum Time: must be greater than the minimum time and is only used in trigger mode (check the operation of the trigger mode in the device manual if you want to receive the monitoring variables only when there is any change on their values);
- Command: HART command that sends the variables desired by user (e.g. , the command 3 sends values of PV, SV, TV and QV, when available);
- Burst Mode: Once all parameters have been configured, activate Burst mode.
- Acquisition based on Burst time parameter that reduces the consumption of the device to perform only one acquisition immediately before the burst transmission. If this parameter is disabled, the device will execute an acquisition every two seconds, regardless of the Burst Minimum Time.

j. After some time negotiating with the gateway, the device will start publishing the configured command at a minimum time rate configured. The **ACK** icon is shown on the display (if available) when the device enters in Burst Mode and the icon **F(t)** blinks on the moment that the command burst is sent.

ATTENTION

The Burst mode configurations remain even after the shutdown of the device, i.e., when it is turned on, the device connects to the network automatically in Burst mode with the same time and command configured. The higher the refresh rate, the lower the lifetime of the battery and vice versa. Configure a refresh rate that allows the device to last few years.

k. After the general network configuration, wait a period of about 1 hour for the network starts to operate 100% optimized.

ATTENTION

There is a battery estimated lifetime parameter that indicates the expected duration in days of the device. This parameter is recalculated every 60 minutes and its value should only become valid after two or three hours of operation of the device on the network (time required for consumption optimization). When this value is near the end, the user will receive a warning in the device status and in the display (when available). When you replace the Battery Module (Smar code 400-1209) you have to configure the replacement via configurator that will restart the counting of the estimated lifetime for the new module.

ATTENTION

Do not discard the Module of Batteries in regular trash. Use a proper disposal for batteries or chemical waste.

Verifying the Range of Device

Identify which distance to be considered according to the type of environment to install the device:

- Strong Obstruction - about 30 m (10 ft.). Very dense environments in relation to devices, pipes, cables, etc. Consider a place where you are not normally able to travel.
- Average Obstruction - about 75 m (25 ft.). Environment which have space among devices in

relation to the rest of the plant.

- Light Obstruction - 150 m (50 ft.). Consider an open environment that has some kind of obstruction such as a silo or a tank. Although the obstruction is large, around the obstacle there is enough free space for propagation of the RF waves.
- Line of Sight - up to 225 m (75 ft.). Consider that the antenna's device "sees" directly the antenna of another network device, without any obstacle between them. Furthermore, the height difference between them should not have an angle greater than 5 degrees.

To mount the device near the ground, below ground level or under water, since the RF signal is absorbed into soil or water and does not propagate, can significantly reduce the range of the devices. Additionally, to mount the device outside the network area (gateway), for example, considering a network in an open environment and installing the device inside a closed room, also contributes to signal attenuation, because signal will not propagate very well within concrete, wood, etc.

Gateway commissioning

The gateways can have a remote connection to the antenna, allowing them to be installed indoors and only the antenna is in the network environment .

- a) Make sure that the gateway is available to the host system;
- b) Check the gateway and make sure it has at least five devices directly connected to it;
- c) Check if 25 % of the devices are connected directly to the gateway. If necessary, add repeaters;
- d) The gateway connects the devices to the host system. Thus, check if the data of the devices are coming to the applications that subscribe them.

We recommend a visit to the [HART Communication Foundation](#) website for additional information about the *WirelessHART* protocol such as *WirelessHART* project planning, positioning of devices, commissioning and verification tools, and practices.

RP400 WirelessHART

The RP400WH is not a process element, but a network element. The concept of *WirelessHART* network is that each of its devices acts as a repeater, hence the absence of the "repeater" element in the structure description of this type of network.

The RP400WH is a device dedicated to the *WirelessHART* network and has the primary function to extend the range of this network, being a router agent that simplifies the project and implementation of a wireless network. It has no role in the industrial process. A *WirelessHART* communication network is structured in loops and adopts an architecture using "Mesh" network. "Mesh" networks allow network nodes to communicate with each other by establishing redundant paths to the base, increasing reliability, because if one path is blocked alternative routes will exist so that the message reaches its final destination. This type of network also enables scalability by simply adding to the network more nodes or RP400WH repeaters. Another feature is that the larger the network the more reliable because more alternative paths are created automatically.

The main features of RP400WH are:

- *WirelessHART* digital communication;
- Increased communication routes facilitating the *WirelessHART* network scalability;
- Increased reliability through alternate paths in the mesh network;
- Solution with excellent cost/benefit.

INSTALLATION

General

NOTE

For hazardous area installations the IEC 60079-14 standard recommendations must be followed.

Although the RP400WH has an outstanding performance, proper installation is essential to maximize its efficiency.

Humidity is fatal to electronic circuits. In areas subjected to high relative humidity level the O-rings for the electronic housing covers must be in good conditions and correctly placed. The covers must be completely closed by hand until the O-rings are compressed. Avoid using tools for this operation. Removal of the electronics cover in the field should be avoided in order to protect electronic circuit from humidity.

The electronic circuit is protected by a humidity proof varnish but frequent exposures to humidity may affect the protection provided. It is also important to keep the covers tightened in place. Every time they are removed, the threads are exposed to corrosion, since these parts are not protected by painting.



ATTENTION

Do not remove cover grease to avoid stuck housing.



ATTENTION

Common cause, random or often failures should not damage the device or result in death and serious injury, harm the environment or result in loss of production or devices.



ATTENTION

Electrical discharge can result in death and serious injury.

Installation Procedure

The repeater is designed to be lightweight and robust at the same time, allowing an easy installation. The following figures show the dimensions and usual mounting positions of the repeater.

ATTENTION

The RP400 *Wireless*HART must always be installed with the antenna positioned upwards.
Do not rotate the antenna, because the cable may break.

To access the display and the main board remove the front cover. This cover can be locked by the cover locking screw. To release the cover, rotate the locking screw clockwise. See Figure 1.5 .

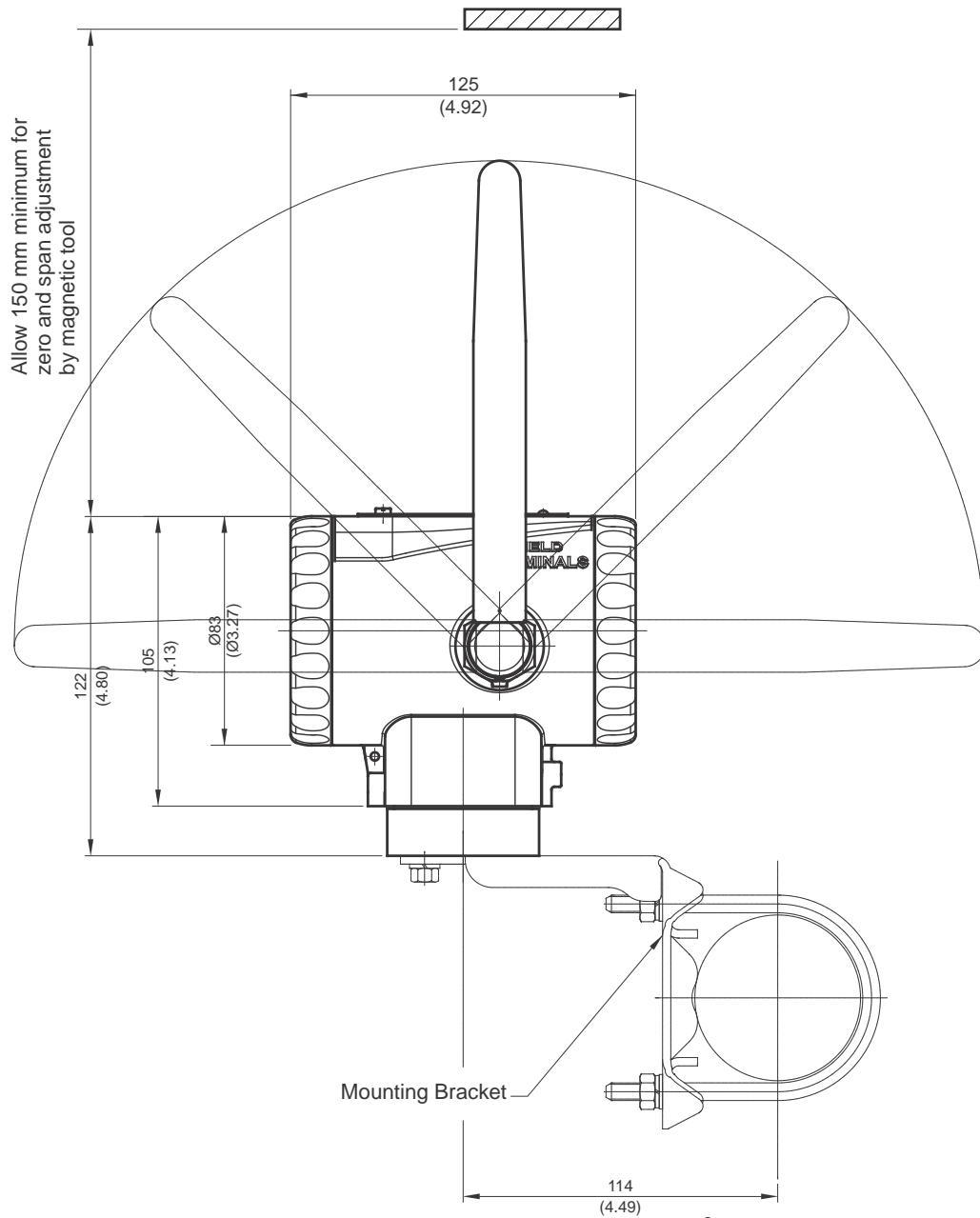

Figure 1. 1 – Dimensional Drawing of RP400 WirelessHART® mounting in vertical

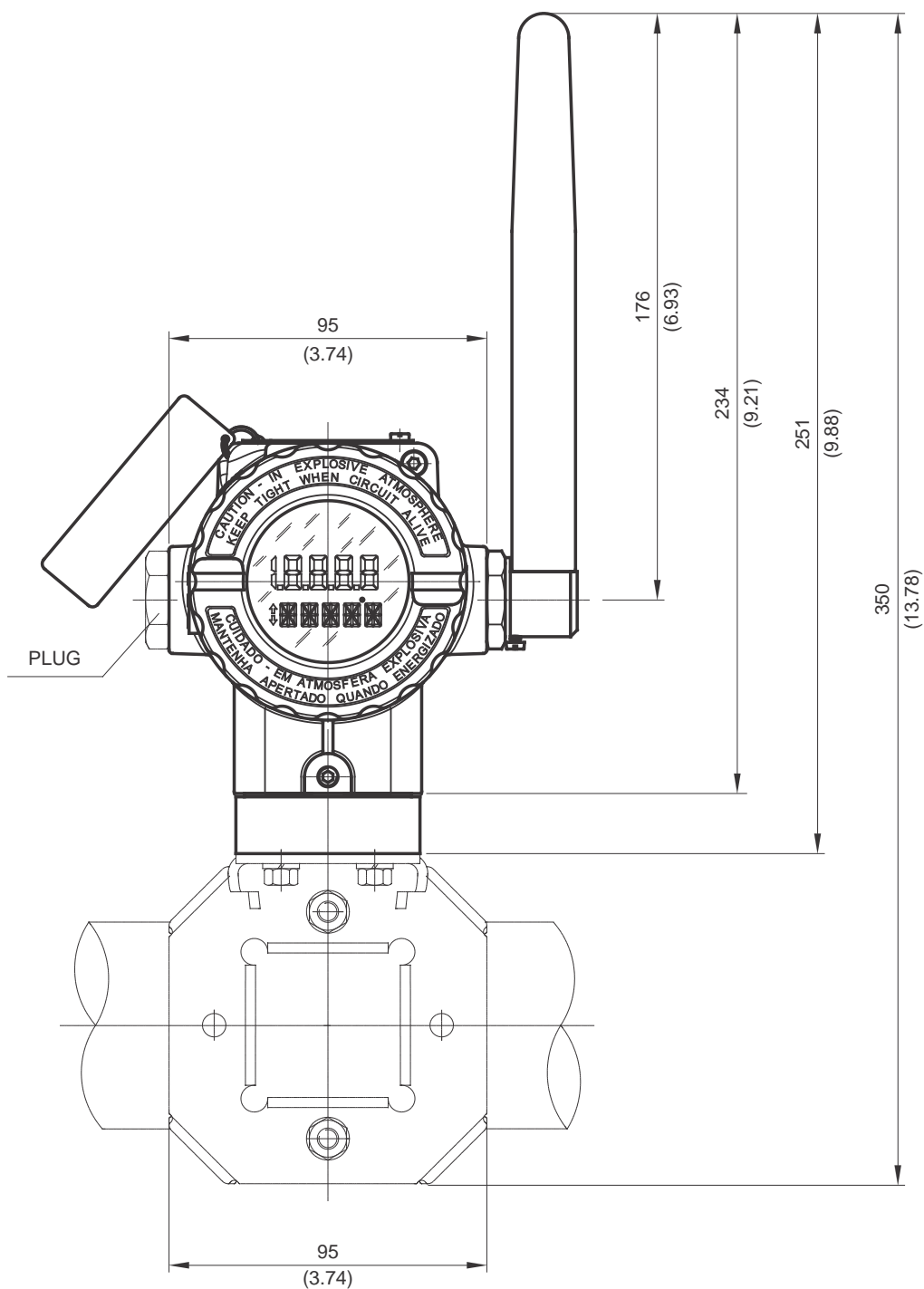

Figure 1.2 – Dimensional Drawing of RP400 WirelessHART® mounting in vertical

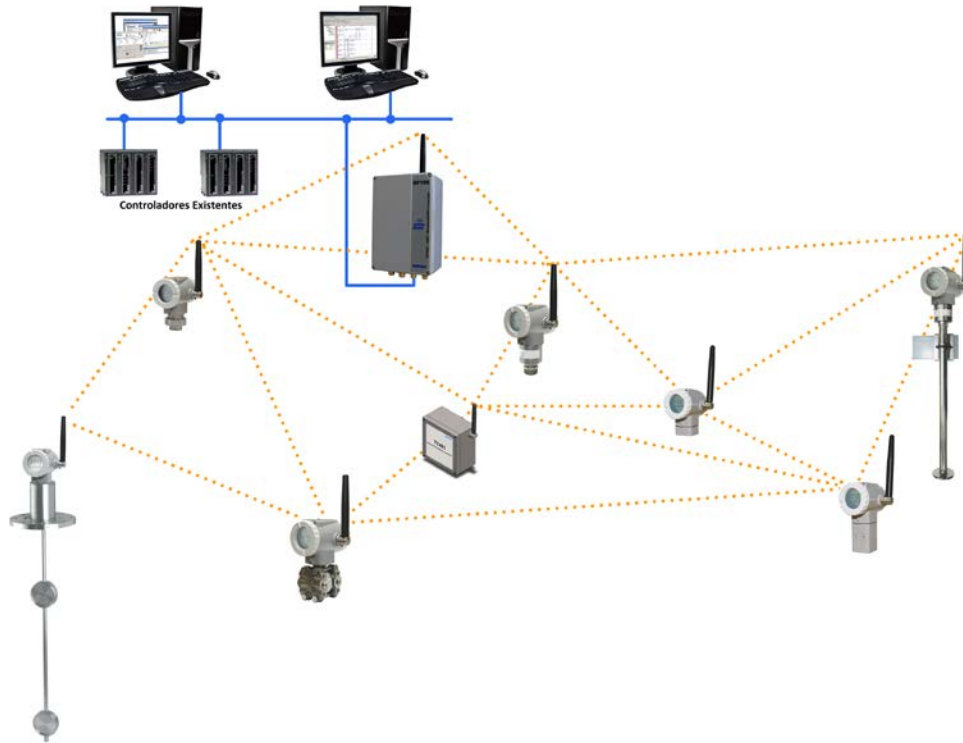

Figure 1.3 – Arrangement scheme of WirelessHART devices

Antenna Rotation

The antenna does not have rotation limits to allow easier device installation in several areas and positions. However, it is suggested that its movement is restricted to the upper 180° (90° left and 90° right with the device vertically) identified by the label on the device. See the next figure.



Figure 1.4 – Antenna rotation limits

In case of horizontal mounting adjust the antenna to the vertical position, as shown in following figure.

Maintenance Port

The communication port allows local communication with the repeater using a HART configurator connected to communication terminals "CN1" and "CN2" which are shown in the next figure.

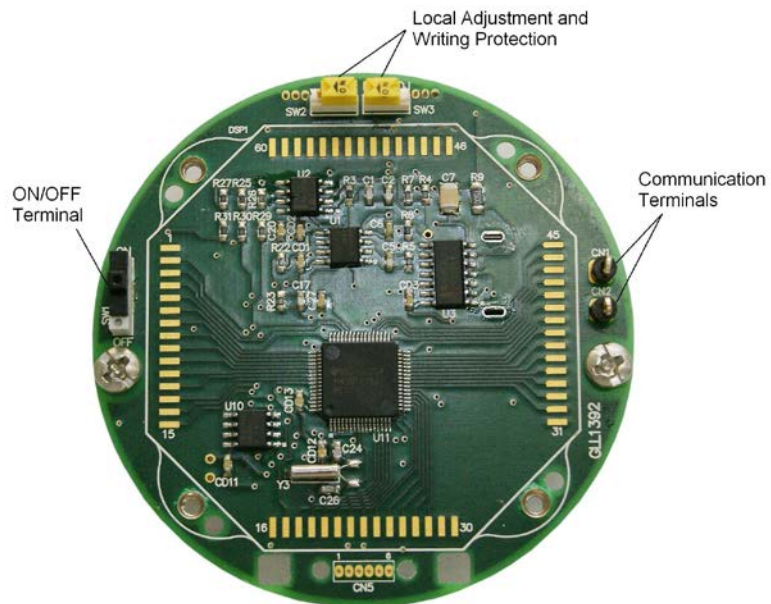

Figure 1.7 – Repeater maintenance port

A configurator can be connected to the communication terminals of the repeater through its connection terminals.

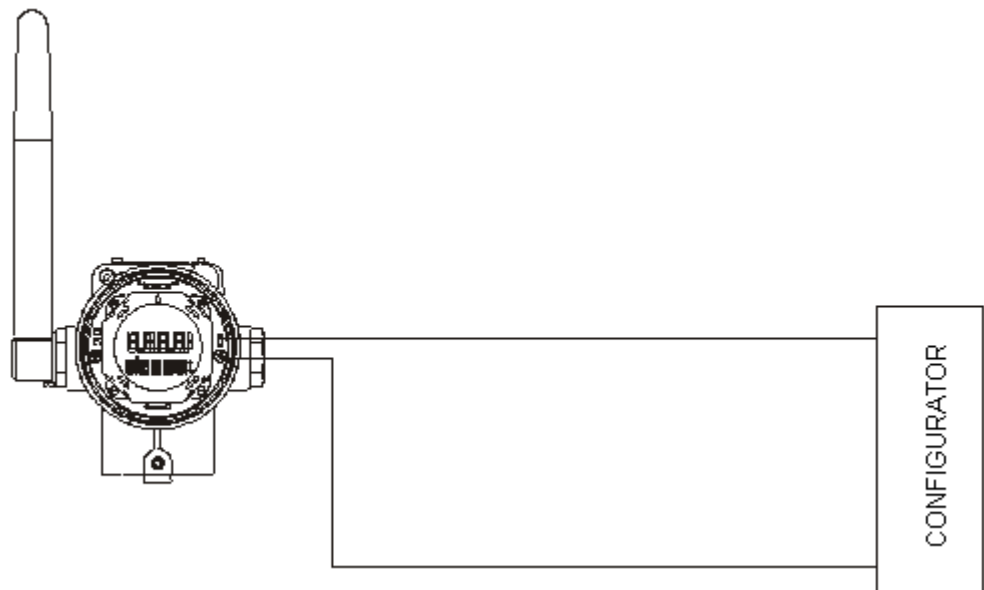

Figure 1.8 – Wiring diagram of configurator to RP400

Installation in Hazardous Areas

ATTENTION

Explosions can result in death or serious injury besides financial damage. Installation of this instrument in an explosive environment must be compliant with the national standards and according to the local environmental protection method. Before proceeding with the installation match the certificate parameters according to the environmental classification.

The instrument modification or replaced parts supplied by any other supplier than authorized representative of Smar Equipamentos Industriais Ltda is prohibited and will void the Certification.

Repeaters are marked with options of the protection type. The certification is valid only when the protection type is indicated by the user. When a specific type of protection is selected, any other type of protection cannot be used.

To install the housing in hazardous areas at least 6 full turns on cover threads must be done. The housing must be locked using locking screw (Figure. 1.6).

The cover must be tighten with at least 8 turns to avoid the penetration of humidity or corrosive gases until it touches the housing. Then, tighten more 1/3 turn (120°) to guarantee the sealing. Lock the covers using the locking screw (Figure 1.6).

Intrinsically Safe

ATTENTION

In hazardous areas with intrinsically safe and non-incendive requirements the circuit component parameters and applicable installation procedures must be observed.

For free access to the device in the explosive environment, ensure the instruments are installed in accordance with intrinsically safe and non-incendive field wiring practices.

Do not remove the repeater cover when in operation.

Section 2

OPERATION

The RP400 *WirelessHART* performs no sensor measurement other than the Battery Module voltage. The RP400 *WirelessHART* constantly checks the wireless network status.

Functional Description - Circuit

Refer to the block diagram below.

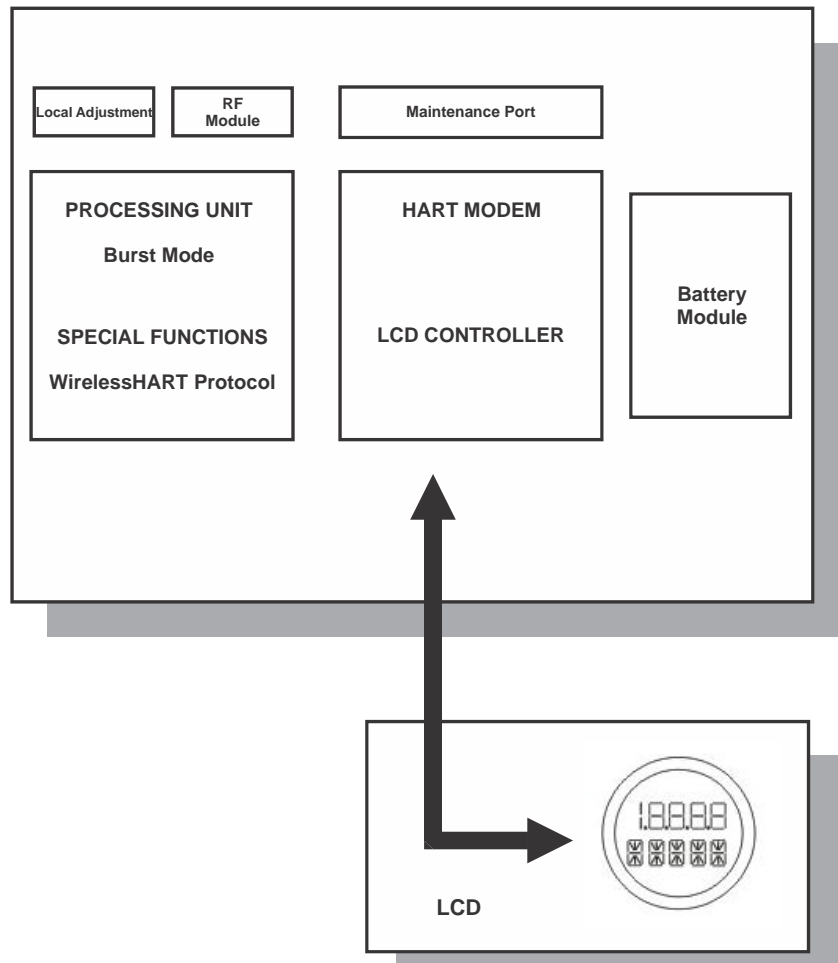

Figure 2.1 - RP400 WirelessHART Block Diagram

Central Processing Unit (CPU) and FRAM

The CPU is the intelligent portion of the repeater, being responsible for the management and operation of all other blocks. The firmware is stored in a FLASH memory while the calibration data, identification and configuration are stored in nonvolatile FRAM. For temporary data storage the CPU uses an internal RAM. The data in the RAM is lost if power is switched off.

HART Modem

It modulates a communication signal in the communication port. A "1" is represented by 1200 Hz and "0" by 2200 Hz. The function of this system is to make possible the exchange of information between the configurator and the repeater, through Master-Slave type digital communication. Therefore, the repeater demodulates the signal received serially from the configurator through the maintenance port, after treating it appropriately; it modulates the response to be sent. The HART[®] uses FSK technology to modulate the signal.

Battery

The Battery Module has 7.2V, consisting of 2 primary lithium batteries (Li-SOCl₂) of 3.6V. Each battery has 2.5 grams of lithium, or 5.0 grams for the Battery Module.

ATTENTION

Do not use another type of power supply other than Battery Module provided by Smar (code 400-1209).

Under normal use the batteries do not offer risk of spontaneous reaction when handled properly. Caution should be taken to falls, high temperature and short circuit in the Battery Module, so that it does not offer any risk or malfunction.

Even with discharged batteries hold the same care since they still offer danger. Never attempt to disassemble, modify or recharge the batteries as this may result in leakage or explosion.

The Battery Module should preferably be stored in an environment below 30°C, dry, ventilated and subject to less variation in temperature.

ATTENTION

Do not discard the Battery Module in regular trash. Use a proper disposal for batteries or chemical waste.

When replacing the Battery Module (Smar code 400-1209) user must configure the replacement via configurator restarting the counting of the estimated lifetime for the new module.

For additional information and first aid, see Appendix B - "Battery Safety Datasheet" or refer to the manufacturer's website: <http://www.tadiranbat.com/index.php/shipping-and-information>

Display Controller

It receives the data from the CPU and activates the LCD segments.

Display

The display will show alternately, at an interval of 3 seconds, the voltage of Battery Module and wireless network status.

The various fields and status indicators are explained in Figure 2.3

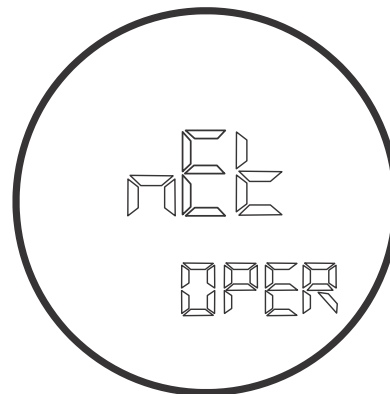

Figure 2.2 – Typical display in monitoring mode

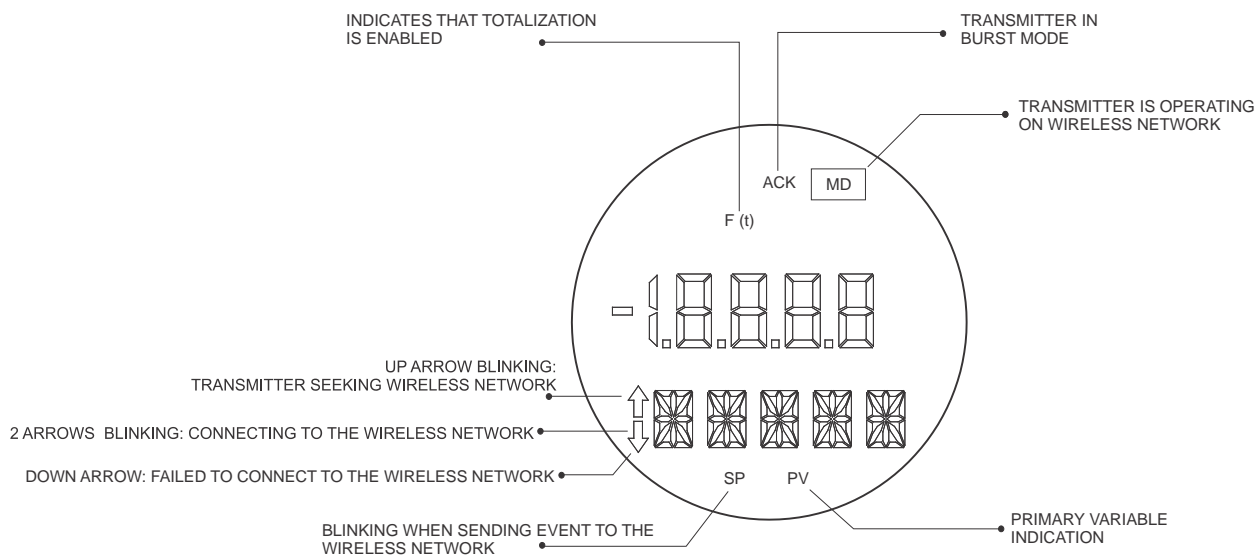

Figure 2.3 – Display

Local Adjustment

For configuration via local adjustment the following actions are necessary:

- The write protection jumper must be disabled;
- The local adjustment jumper must be enabled.

See on Figure 1.7 the location of Local Adjustment and Write Protection jumpers on the main board.

The repeater has, under the identification plate, two holes that allow the placement of the magnetic key to perform the Local Adjustment.

The holes are marked with **Z** (Zero) and **S** (Span) and from now on will be designated simply by **(Z)** and **(S)**, respectively. See the following figure:

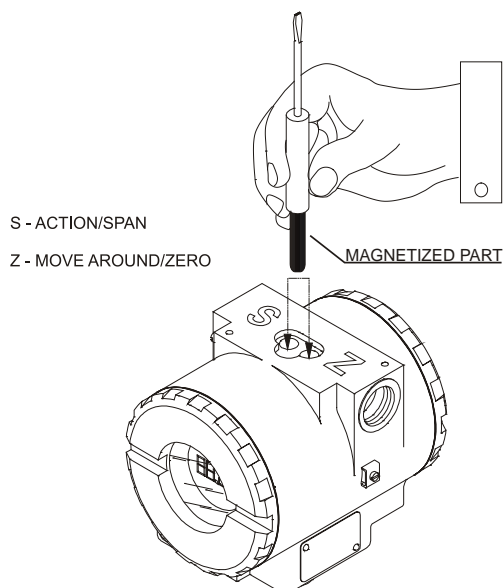

Figure 2.4 – Local Adjustment key

Browsing the functions and their branches works as follows:

- Inserting the handle of the magnetic tool in **(Z)**, the device passes from the normal measurement state to the configuration state. The repeater software automatically starts to display the available functions in a cyclic routine.

- Apply the magnetic tool in (Z) to navigate through all available configuration options;
- Once the display shows the desired option, change the magnetic tool to (S) to select and navigate within the branch of the selected option. Removing the magnetic tool will allow the device to save the configurations (in case of changing).

The options available for RP400WH local adjustment are:

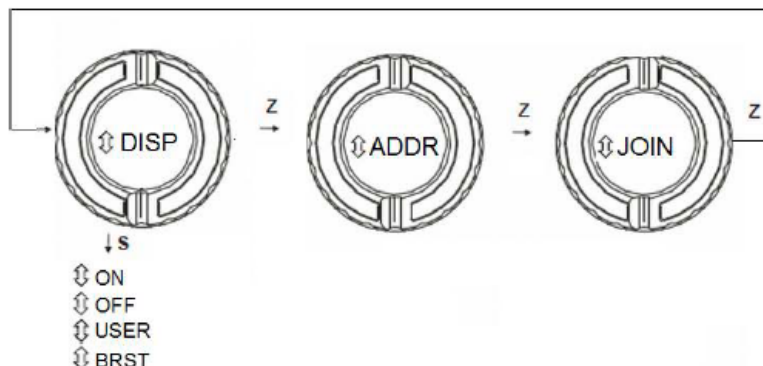

Figure 2.5 – Local adjustment options

The **DISP** option changes the configuration of display mode. There are four modes supported:

- OFF: display always turned off
- ON: display always turned on
- USER: display normally off but activated when user inserts the magnetic key (S)
- BRST: display normally off but activated when device sends a burst command.

The ADDR and JOIN options are read-only and are used to identify the configuration address by maintenance port and the device status on the *WirelessHART* network, respectively.

Write Protection

The write protection function can be activated by two ways: hardware (switch on main board) and software. The writing of any parameter only will be able if both protections are disabled.

Another way to protect the writing, but partially, is using the Lock Device option (*WirelessHART*).

This option is used in *WirelessHART* devices to block the writing for only one configuration master, **Communication Port** or **Gateway**. With this function user avoids configuration conflicts when acting by one of the configurators in dangerous situations.

The types of locking are:

- Unlocked: both configurators have write permission.
- Temporarily Locked: only the configurator that locked the device has write permission. However, after restarting the device its state returns to Unlocked.
- Permanently Locked: only the configurator that locked the device has write permission, and its state remains even after restarting the device.
- All locked: no configurator has write permission until the device is unlocked by the same configurator that locked it.

ATTENTION

The use of this function is intended only for special occasions, which the security parameter writing is critical and fast. After writing, the configurator must return the device to the Unlocked mode.

Section 3

MAINTENANCE

General

The network repeaters RP400 *WirelessHART* are extensively tested and inspected before being sent to the user.

All maintenance service should be done by a qualified person and the exchange of components (supplied by Smar) should only be performed by people certified to do so.

Diagnostic with Display

The display can show failure messages in alphanumeric segment. When these messages are shown, the repeater automatically goes to a safe state. These messages are shown in Table 3.1.

DIAGNOSTIC MESSAGES	PROBABLE SOURCE OF TROUBLE
FAIL RADIO	Indicates problem in the radio
LOW BATT	Indicates low battery level
FAIL BATT	Indicates critical battery level

Table 3.1 – Diagnostic with Display

Disassembly Procedure

ATTENTION
This type of operation should be done in a safe area and the repeater turned off.

WARNING
The board has CMOS components which may be damaged by electrostatic discharges. Observe correct procedures for handling CMOS components. It is also recommended to store the circuit boards in electrostatic-proof cases.

IMPORTANT
To avoid damage do not rotate the electronic housing more than 270° starting from the fully threaded. See the following figure.



Figure 3.1 – Housing safety rotation

IMPORTANT
To avoid device damage, do not rotate the antenna below the 180° imaginary line relative to the device base. If there is the need to rotate the antenna, loosen the locking screw and the move it just above this line. See the following figure. For more details see the topic "Antenna Rotation" in section 1.

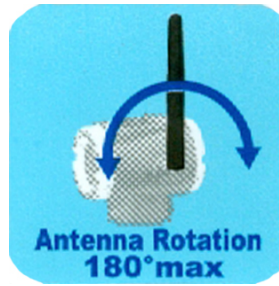







Figure 3.2 – Antenna safety rotation

Here is the disassembly procedure of RP400WH. Figure 3.3 indicates the position of the components mentioned in this description.

- a)  Open the frontal (1) and rear covers (15);
- b)  Open the bottom cover (19), loosening the housing fixation screw (6);
- c)  Remove the main board (5) on the front housing (8), disconnecting the radio board (10);
- d)  Disconnect Battery Module (13) from radio board at the point indicated and unscrew it from the housing;
- e)  Disconnect the antenna cable from the radio board, as shown in the picture. Unscrew the radio board from housing;
- f)  Loosen the antenna (17) with the aid of a wrench. Use the wrench in the way is being shown in the picture, always beneath the antenna;

Assembly Procedure

ATTENTION

This type of operation should be done in a safe area and with the repeater turned off.

Here is the assembly procedure of RP400WH. Figure 3.3 indicates the position of the components mentioned in this description.



- a) First, make the antenna assembly (17) on the housing side (8) indicated by "FIELD TERMINALS";



- b) Tighten the antenna with a wrench. Use the wrench as shown in the picture, always beneath the antenna. At the end, keep the antenna in a vertical position;



- c) Screw the radio board (10) on the back of the housing. Pass the antenna cable through the hole indicated in the picture and connect it to the radio board as shown in the picture;



- d) Screw Battery Module (13) and connect it to the radio board at the point indicated;



- e) Place the main board (5) on the front of the housing and connect the radio cable to it. After connection, screw the board to the housing;



- f) Fit the cover (19) at the bottom of the housing, locking it with the fixing screw (6);



- g) End threading the front (1) and rear (15) covers.

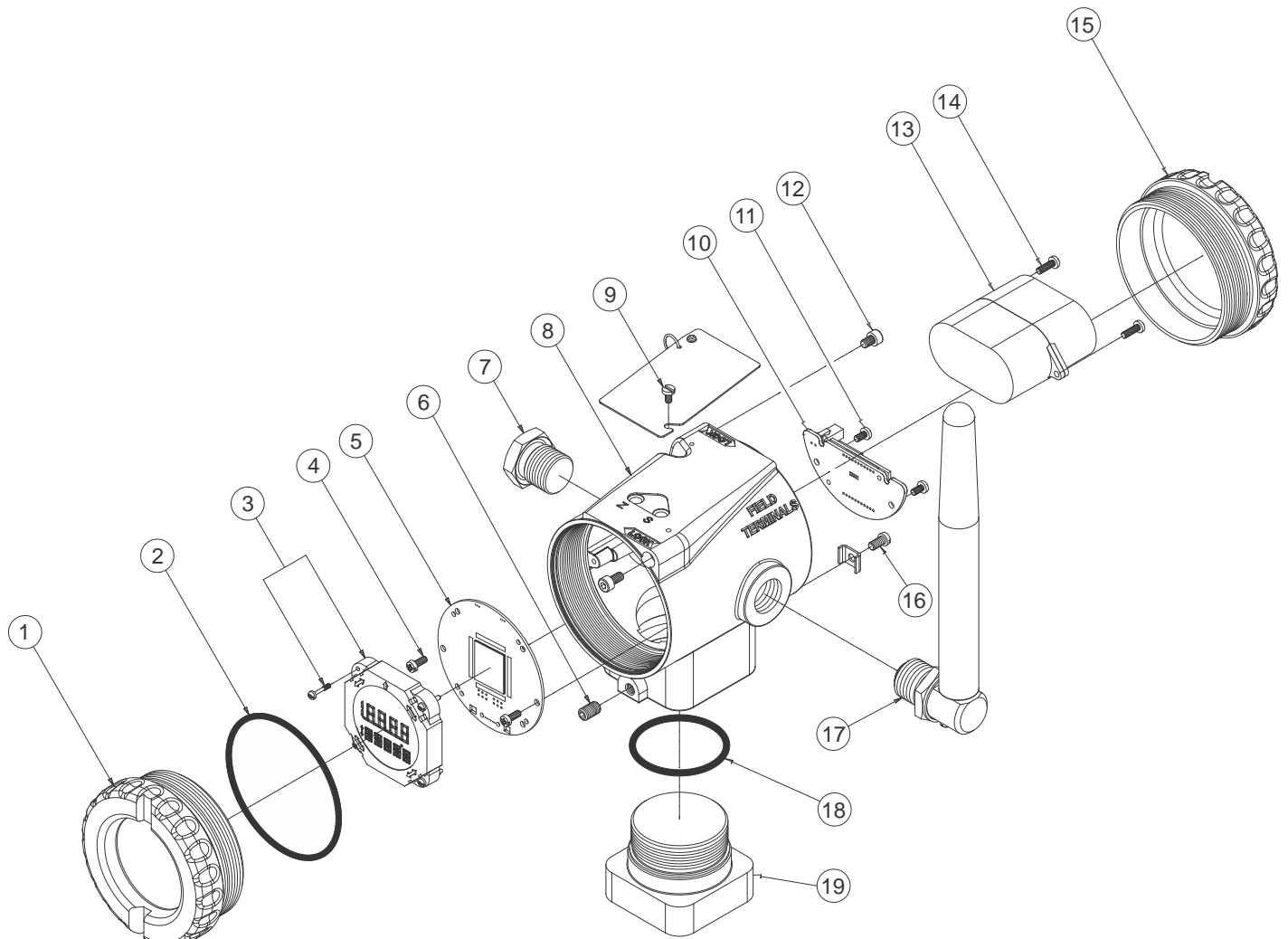

Figure 3.3 – Exploded view

Troubleshooting

1) Device does not connect to the *WirelessHART* network.

Possible causes:

- The device is turned off;
- The Network Manager/Gateway is turned off;
- The device is far from the Network Manager/Gateway or other device connected to it;
- Network ID and Join Key are not configured correctly;
- The antenna is not connected to the Network Manager/Gateway or to the device;
- There is an Access Control List in the Network Manager/Gateway and the device is not on this list ;
- Maximum number of devices configured in Network Manager/Gateway has been reached.

2) Device connects and disconnects to the *WirelessHART* network.

Possible causes:

- Low battery or bad contact in the powering causing a device restarting;
- The connectivity related to the neighbors is unstable (moving obstacles or distance in the limit);

3) Devices in the operation range but with low communication stability.

Possible cause:

- Interference. Approximate the devices to get a better stability.

Accessories and Spare Parts

ACCESSORIES	
ORDERING CODE	DESCRIPTION
SD-1	Magnetic tool for local adjustment.
Palm*	Palm Handheld, 16 Mbytes, including installation software and startup of HPC401.
HPC401*	HART Interface → (HPC401 Plus) for Palm, including configuration package for Smar transmitters and generic transmitters.
HPC401 Plus *	HART [®] Interface
CONF401*	PC-based Smar configurator
HI321*	HART Interface for CONF401

* For upgrades of devices and software HPC401 or CONF401 visit: <http://www.smarresearch.com> .

SPARE PARTS LIST FOR REPEATER				
DESCRIPTION OF PARTS		POSITION	CODE	CATEGORY (NOTE1)
FRONT COVER (WITH WINDOW FOR INDICATION)		01	400-0822	
COVER O-RING		02	204-0122	B
DISPLAY (WITH SCREWS)		03	400-0828	
MAIN BOARD FIXATION SCREW	CARBON STEEL 316 STAINLESS STEEL	04	400-0905 400-0832	
MAIN BOARD		05	400-1243	A
COVER LOCKING SCREW		06	400-1121	
M20 x 1,5 HEXAGONAL PLUG		07	400-0810	
HOUSING 400W SERIES (NOTE 2)	ALUMINUM 316 STAINLESS STEEL	08	400-1205 400-1206	
PLATE FIXATION SCREW		09	204-0116	
RADIO BOARD		10	400-1211	
RADIO BOARD FIXATION SCREW		11	400-1212	
COVER LOCKING SCREW		12	204-0120	
BATTERY MODULE		13	400-1209	
BATTERY MODULE FIXATION SCREW		14	400-1210	
REAR COVER (WITHOUT WINDOW FOR INDICATION)		15	400-1208	
EXTERNAL GROUND SCREW	HOUSING IN 316 STAINLESS STEEL HOUSING IN ALUMINUM	16	400-0826 400-0904	
WIRELESS ANTENNA		17	400-1214	
2131 BUNA-N O'RING		18	204-0113	

SPARE PARTS LIST FOR REPEATER				
DESCRIPTION OF PARTS		POSITION	CODE	CATEGORY (NOTE1)
DEVICE BASE		19	400-1244	
BRACKET	CARBON STEEL FOR 2"PIPE 316 STAINLESS STEEL		214-0801 214-0802	

NOTES	
1.	For category A it is recommended to keep in stock one set for 25 installed parts, and for category B one set for 50 installed parts.
2.	It includes screws (cover locking and grounding) and identification plate without certification.
3.	O-Rings are packaged in packs of 12 units.

Returning Materials

Should it become necessary to return the repeater and/or configurator to SMAR, simply contact your local agent or SMAR office, informing the defective device's serial number, and return it to our factory.

In order to expedite analysis and solution of the problem, the defective item should be returned with a description of the failure observed, with as much details as possible. Other information concerning to the instrument operation, such as service and process conditions, is also helpful. For this, fill out the SRF (Service Request Form). The SRF is available on Appendix A.

Devices returned or to be revised outside the guarantee term should be accompanied by a purchase order or a quote request.

ATTENTION
The device must have its Battery Module disconnected before being sent for safety and shipping standards. To do this, first turn it off by front switch (Figure 1.7). Disconnect the Battery Module and radio board, located at the rear of the device.

Section 4

TECHNICAL CHARACTERISTICS

FUNCTIONAL SPECIFICATIONS	
Battery Module	The module consists of 2 primary lithium batteries (Li - SOCl ₂) of 3.6 V, totaling 7.2 V. Duration Burst Mode at 8 seconds, @25°C, network with at least 3 neighbor devices: 6 years. Note: The Battery Module used in the transmitters must be provided exclusively by Smar (Battery Module – Code 400-1209).
Display	Liquid crystal display with 4 ½ numeric digits, 5 alphanumeric digits, function and status icons
Communication Protocol	HART protocol Version 7, with the commands set of RP400 WirelessHART® HART® is a registered trademark of HART Communication Foundation.
Output Signal	Digital output via radio frequency 2.4 GHz, according to HCF_SPEC-65 Rev. 1.0
Measurement Type	Voltage of Battery Module
Configuration	Remotely with external configurator via <i>WirelessHART</i> network Locally with wired configurator in the maintenance port.
Temperature Limits	-40 °C to 85 °C

PHYSICAL SPECIFICATIONS	
Mounting	In SAE 1020 Carbon Steel with electrostatic polyester painting or 316 stainless steel Accessories (screws, nuts, washers and U-clamps) in carbon steel or 316 stainless steel
Housing	Aluminum and stainless steel
Electronic Circuit	2.4GHz omnidirectional antenna Coaxial cable to connect the antenna to the radio board Battery Module with 2 units Type 'C'
Identification Plate	316 stainless steel plate with label in special plastic

SPECIFICATIONS OF OPERATION PROTECTION	
Operation Counter	Counting of configuration change operations
Configuration Protection	Write protection via hardware and software
Certification	Intrinsic safety (pending) and weather proof

SPECIFICATIONS OF HUMAN MACHINE INTERFACE			
	ITEM	ICON	DEFINITION
Status Indication on Display	1	PV	Primary variable indication
	2	↑↑	Blinking when the repeater is searching for wireless network
	3	↕	Blinking when the repeater is connecting to the wireless network
	4	MD	Repeater is operational on a wireless network
	5	↓↓	Failed to connect to the wireless network
	6	ACK	Repeater in burst mode.
	7	F(t)	Turn on when sending command in burst mode
	8	SP	Turn on when an event is sent by the device.

Ordering Code

MODEL	WIRELESSHART NETWORK REPEATER	
RP400	COD.	Mounting Bracket
	0	Without bracket
	1	Carbon steel bracket
	2	Stainless steel bracket
	COD.	Housing Material
	A	Aluminum (default) (IP/TYPE)
	I	316 Stainless steel – CF8M (ASTM – A351) (IP/TYPE)
	COD.	Painting
	0	Gray Munsell N 6.5 Polyester (Default)
	8	Without painting (1)
	COD.	Certification Type (2)
	I	Intrinsic safety
	N	Without certification
	COD.	Certifier Body (2)
	0	Without certifier body
	5	CEPEL (pending for intrinsic safety)
	COD.	Tag Plate (3)
	0	With TAG, when specified
	1	Blank
	2	User specification

RP400	-				-				-	*
-------	---	--	--	--	---	--	--	--	---	---

* Leave blank if no special options

NOTES
(1) Not available for aluminum housing.
(2) For hazardous areas.
(3) Rectangular plate in 316 stainless steel.

Special Options

Certification for telecommunications	W1	ANATEL - Brazil
--------------------------------------	----	-----------------

Appendix A

		SRF – Service Request Form WirelessHART Repeater		Proposal No.: (1)	
Company:			Unit:		Receipt of Remittance:
COMERCIAL CONTACT			TECHNICAL CONTACT		
Full name:			Full name:		
Position:			Position:		
Phone:		Extension:		Phone:	
Fax:		Extension:		Fax:	
E-mail:			E-mail:		
EQUIPMENT DATA					
Model: RP400WH			Serial Number:		TAG:
Firmware Version:					
PROCESS INFORMATION					
Application Type:					
Environment Temperature (°C)			Work Temperature (°C)		
Min.:		Max:		Min.:	
Max:		Min.:		Max:	
Operation Time:			Failure Data:		
FAILURE DESCRIPTION					
(Please, describe the behavior of the fail, if it is repetitive, how it exactly happens, and so on.)					
Did device detect the fail? Yes () No ()			What is the message in the display?		
MAINTENANCE INFORMATION					
Did you allow the firmware upgrade? Yes () No ()			Certification plate: Will it maintained the certification? Yes () No ()		
Main board configuration: () Original factory configuration () Default configuration () Special configuration (should be informed by the client. Please, use the space below)					
NOTES					
SUBMITTER INFORMATION					
Submitted by:		Title:		Section:	
Phone:		Extension:		E-mail:	
Date:		Signature:			
For warranty or non-warranty repair, please contact your representative. Further information about address and contacts can be found on www.smar.com/contactus.asp					
NOTE					
(1) This field should be filled out by the Smar.					

BATTERY SAFETY DATASHEET

Section 1 – Identification

Manufacturer: Tadiran

Model: TL-5920

US office address: 2001 Marcus Avenue, Suite 125E, Lake Success, NY 11040

Emergency Telephone: 1-800-424-9300

Information Telephone: 1-516-621-4980

Section 2 – Composition

Ingredients	%
Lithium Metal (Li)	<5%
Thionyl Chloride (SOCl ₂)	<47%
Carbon (C)	<6%
Aluminum Chloride (AlCl ₃)	<5%
Lithium Chloride (LiCl)	<2%
Glass	<1%
PVC	<1%
PTFE	<1%
Steel, nickel and inherent components	balance

Section 3 – Hazard Identification

The batteries described herein are hermetically sealed and are not hazardous when used according to the manufacturer's recommendations.

Batteries should not be exposed to short-circuit, recharged, punched, burned, crushed, immersed in water, forced to discharge or placed in temperatures above the range specified for the product. In these cases there is a risk of fire and explosion.

Section 4 – First aid

In case of rupture, explosion or leakage, remove personnel from the contaminated area and ventilate it to release smoke, corrosive gases and odor. Seek medical help immediately.

Eyes - flush with plenty of water for at least 15 minutes (remove contact lenses if possible) and then seek medical attention.

Skin - Remove contaminated clothing and flush affected skin with plenty of water for 15 minutes and then seek medical attention.

Inhalation - look for an area with fresh air, rest, use artificial respiration, if necessary, and seek medical attention.

Ingestion - rinse your mouth, do NOT induce vomiting, drink lots of water, and then seek medical attention.

Section 5 – Fire fighting

If the batteries are directly involved in fire DO NOT USE: WATER, SAND, CO₂ and DRY CHEMICAL POWDER EXTINGUISHERS.

If the batteries are in a location adjacent to the fire, it can be combated according to the combustible material (paper or plastic, for example). In this case, the use of large quantities of cold water would be an effective way to combat.

To firefighting use equipment and protective clothing that prevent contact with battery solution. The fire must be fought at a safe distance and after evacuation of the area.

Batteries may explode when exposed to: excessive heat (above 150 °C), recharged, discharged below 0V, punched and crushed. Hydrogen Chloride (HCl) and sulfur dioxide (SO₂) can be formed during thermal decomposition of Cl₂.

Section 6 – Leakage

The material contained in the batteries will leak only if exposed to abusive conditions.

On the occasion of leakage: contain the leakage if using protective clothing and ventilate the area well. Cover with Sodium Carbonate (Na₂CO₃) and keep away from water, rain or snow. Put in a secure container and pour into proper trash, according to local regulatory standards.

Section 7 – Handling and storage

Never attempt to disassemble or modify the batteries as this may result in accident.

HANDLING – do not short-circuit the terminals or expose to temperatures above the range specified for the battery, overload, force discharge or thrown in fire. Do not punch, crush or immerse in water.

STORAGE – preferably store in an environment below 30 °C, dry and ventilated subject to less variation in temperature.

Do not store the batteries near heating equipment, nor expose to direct sunlight for long periods. Elevated temperatures may result in shortened batteries life and degrade their performance.

Do not store batteries in high humidity environment for long periods.

The batteries should not be recharged. High pressures can cause deformities and release of chemicals from the battery.

Ecological Information: When properly used or discarded, the batteries pose no danger to the environment. The batteries do not contain mercury, cadmium or lead. Do not let internal components exposed to the marine environment.

Disposal: Absolutely not incinerate batteries. Dispose of batteries according to local regulations.

Transportation: Batteries are considered "Dangerous Goods" when transported in or out of equipment.

For additional information, see the manufacturer's website
<http://www.tadiranbat.com/index.php/shipping-and-information>