

smar
FIRST IN FIELDBUS

LD302

SEP / 14
LD302
VERSION 3

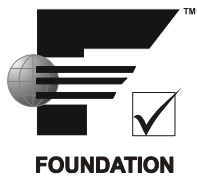

OPERATION & MAINTENANCE
INSTRUCTIONS MANUAL

FIELDBUS PRESSURE TRANSMITTER

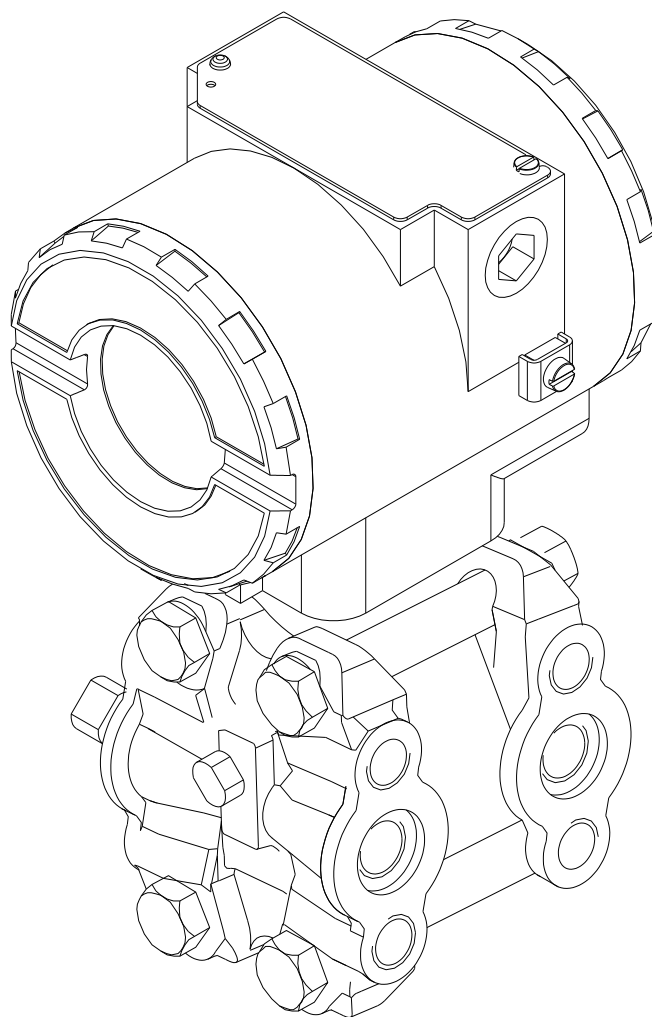

smar
www.smar.com

Specifications and information are subject to change without notice.
Up-to-date address information is available on our website.

web: www.smar.com/contactus.asp

INTRODUCTION

The **LD302** is part of first generation of Fieldbus devices. It is a transmitter for differential, absolute and gauge pressure, level and flow measurements. It is based on a field-proven capacitive sensor that provides reliable operation and high performance. The digital technology used in the **LD302** enables the choice of several types of transfer functions, and easy interface between the field and the control room. Also it has several interesting features that will considerably reduce the installation, operation and maintenance costs.

The **LD302** is part of Smar's complete 302 line of Fieldbus devices.

Fieldbus is not only a replacement for 4-20 mA or intelligent / smart transmitter protocols, it contains much more. Fieldbus is a complete system enabling distribution of the control function to equipment in the field.

Some of the advantages of bi-directional digital communications are known from existing smart transmitter protocols: Higher accuracy, multi-variable access, remote configuration and diagnostics, and the multi-dropping of several devices on a single pair of wires.

These protocols are not intended to transfer control data, but maintenance information. Therefore they are slow and too inefficient to be used.

The main requirements for Fieldbus are to overcome these problems. Closed loop control with performance like a 4-20 mA system requires higher speed. Since higher speed means higher power consumption, this clashes with the need for intrinsic safety.

Therefore, a moderately high communication speed has been selected, and the system was designed to have a minimum of communication overhead. Using scheduling, the system controls variable sampling, algorithm execution, and communication so as to optimize the usage of the network, will not lose time. Thus, high closed loop performance is achieved.

Using Fieldbus technology, with its capability to interconnect several devices, very large control schemes can be constructed. In order to be user friendly, the function block concept was introduced (users of SMAR CD600 should be familiar with this, since it was implemented several years ago). The user may now easily build and overview complex control strategies. Another advantage was added: flexibility. The control strategy may be edited without having to rewire or change any hardware.

The **LD302**, like the rest of the 302 family, has several built-in Function Blocks, such as the PID controller, Input Selector and Splitter/Output Selector, therefore eliminating the need for a separate control device. This feature reduces communication, so there is less dead-time and tighter control, not to mention the reduction in cost.

Other function blocks are also available. They allow flexibility in control strategy implementation.

The need for implementation of Fieldbus in small as well as large systems was considered when developing the entire 302 line of Fieldbus devices. They have the common features of being able to act as a master on the network and be configured locally using a magnetic tool, eliminating the need for a configurator or console in many basic applications.

The **LD302** is available as a product of its own, but also replaces the circuit board for the LD301. They both use the same sensor board. Refer to the maintenance section of this manual for instructions on upgrading. The **LD302** is part of SMAR's **Series 302** of Fieldbus devices.

The **LD302**, like its predecessor LD301, has many built-in blocks, eliminating the need for a separate control device. The communication requirement is considerably reduced, and that means less dead-time and tighter control is achieved, not to mention the reduction in cost. They allow flexibility in control strategy implementation.

Get the best results of the LD302 by carefully reading these instructions.

NOTE

This Manual is compatible with version 3.XX, where 3 denote software version and XX software release. The indication 3.XX means that this manual is compatible with any release of software version 3.

Waiver of responsibility

The contents of this manual abides by the hardware and software used on the current equipment version. Eventually there may occur divergencies between this manual and the equipment. The information from this document are periodically reviewed and the necessary or identified corrections will be included in the following editions. Suggestions for their improvement are welcome.

Warning

For more objectivity and clarity, this manual does not contain all the detailed information on the product and, in addition, it does not cover every possible mounting, operation or maintenance cases.

Before installing and utilizing the equipment, check if the model of the acquired equipment complies with the technical requirements for the application. This checking is the user's responsibility.

If the user needs more information, or on the event of specific problems not specified or treated in this manual, the information should be sought from Smar. Furthermore, the user recognizes that the contents of this manual by no means modify past or present agreements, confirmation or judicial relationship, in whole or in part.

All of Smar's obligation result from the purchasing agreement signed between the parties, which includes the complete and sole valid warranty term. Contractual clauses related to the warranty are not limited nor extended by virtue of the technical information contained in this manual.

Only qualified personnel are allowed to participate in the activities of mounting, electrical connection, startup and maintenance of the equipment. Qualified personnel are understood to be the persons familiar with the mounting, electrical connection, startup and operation of the equipment or other similar apparatus that are technically fit for their work. Smar provides specific training to instruct and qualify such professionals. However, each country must comply with the local safety procedures, legal provisions and regulations for the mounting and operation of electrical installations, as well as with the laws and regulations on classified areas, such as intrinsic safety, explosion proof, increased safety and instrumented safety systems, among others.

The user is responsible for the incorrect or inadequate handling of equipments run with pneumatic or hydraulic pressure or, still, subject to corrosive, aggressive or combustible products, since their utilization may cause severe bodily harm and/or material damages.

The field equipment referred to in this manual, when acquired for classified or hazardous areas, has its certification void when having its parts replaced or interchanged without functional and approval tests by Smar or any of Smar authorized dealers, which are the competent companies for certifying that the equipment in its entirety meets the applicable standards and regulations. The same is true when converting the equipment of a communication protocol to another. In this case, it is necessary sending the equipment to Smar or any of its authorized dealer. Moreover, the certificates are different and the user is responsible for their correct use.

Always respect the instructions provided in the Manual. Smar is not responsible for any losses and/or damages resulting from the inadequate use of its equipments. It is the user's responsibility to know and apply the safety practices in his country.

TABLE OF CONTENTS

SECTION 1 - INSTALLATION	1.1
GENERAL.....	1.1
MOUNTING	1.1
HOUSING ROTATION	1.9
BUS AND TREE TOPOLOGY AND NETWORK CONFIGURATION	1.11
INSTALLATION IN HAZARDOUS AREAS.....	1.13
EXPLOSION/FLAME PROOF	1.13
INTRINSICALLY SAFE.....	1.13
SECTION 2 - OPERATION	2.1
FUNCTIONAL DESCRIPTION - SENSOR.....	2.1
FUNCTIONAL DESCRIPTION – ELECTRONICS	2.2
THE DISPLAY	2.3
SECTION 3 - CONFIGURATION	3.1
TRANSDUCER BLOCK.....	3.1
PRESSURE TRANSMITTER BLOCK PARAMETER DESCRIPTION.....	3.1
PRESSURE TRANSMITTER BLOCK PARAMETER ATTRIBUTES.....	3.3
HOW TO CONFIGURE A TRANSDUCER BLOCK	3.4
LOWER AND UPPER TRIM.....	3.5
PRESSURE TRIM - LD302	3.6
THROUGH LOCAL ADJUSTMENT	3.8
CHARACTERIZATION TRIM	3.8
SENSOR INFORMATION	3.10
TEMPERATURE TRIM.....	3.11
SENSOR DATA READING	3.11
TRANSDUCER DISPLAY - CONFIGURATION.....	3.12
DISPLAY TRANSDUCER BLOCK	3.13
DEFINITION OF PARAMETERS AND VALUES	3.13
PROGRAMMING USING LOCAL ADJUSTMENT	3.16
J1 JUMPER CONNECTIONS	3.17
W1 JUMPER CONNECTIONS.....	3.17
SECTION 4 - MAINTENANCE PROCEDURES	4.1
GENERAL.....	4.1
DISASSEMBLY PROCEDURE	4.2
SENSOR CLEANING	4.2
ELECTRONIC CIRCUIT.....	4.3
REASSEMBLY PROCEDURE	4.3
SENSOR MOUNTING	4.3
ELECTRONIC CIRCUIT	4.4
INTERCHANGEABILITY	4.5
UPGRADING LD301 TO LD302.....	4.5
RETURNING MATERIALS.....	4.5
SMAR INSULATOR KIT	4.10
SMAR INSULATOR KIT MOUNTING.....	4.10
APPLICATION WITH HALAR.....	4.14
TECHNICAL SPECIFICATION.....	4.14
PERFORMANCE SPECIFICATION	4.14
TPE – TOTAL PROBABLE ERROR (SOFTWARE).....	4.14
ORDERING CODE FOR THE SENSOR.....	4.16
SECTION 5 - TECHNICAL CHARACTERISTIC	5.1
ORDERING CODE	5.6

APPENDIX A - CERTIFICATIONS INFORMATION..... A.1
EUROPEAN DIRECTIVE INFORMATION A.1
OTHER APPROVAL.....A.1
SANITARY APPROVAL A.1
DEVICE REGISTRATION ITK:..... A.1
HAZARDOUS LOCATIONS CERTIFICATIONSA.1
NORTH AMERICAN CERTIFICATIONS A.2
SOUTH AMERICA CERTIFICATION A.3
ASIA CERTIFICATION A.3
IDENTIFICATION PLATE AND CONTROL DRAWINGA.3
IDENTIFICATION PLATE A.3
CONTROL DRAWING..... A.7

APPENDIX B – SRF – SERVICE REQUEST FORM..... B.1

INSTALLATION

General

NOTE
The installation carried out in hazardous areas should follow the recommendations of the IEC60079-14 standard.

The overall accuracy of a flow, level, or pressure measurement depends on several variables. Although the transmitter has an outstanding performance, proper installation is essential to maximize its performance.

Among all factors, which may affect transmitter accuracy, environmental conditions are the most difficult to control. There are, however, ways of reducing the effects of temperature, humidity and vibration.

The **LD302** has a built-in temperature sensor to compensate for temperature variations. At the factory, each transmitter is submitted to a temperature cycle process, and the characteristics under different pressures and temperatures are recorded in the transmitter memory. In the field, this feature minimizes the temperature variation effect.

Placing the transmitter in areas protected from extreme environmental changes can minimize temperature oscillation effects.

The transmitter should be installed a way as to avoid, as much as possible, direct exposure to the sun or any source of irradiated heat. Installation close to lines and vessels should also be avoided. Use longer sections of impulse piping between tap and transmitter whenever there is a high temperature process. The use of sunshades or heat shields to protect the transmitter from external heat sources should be considered.

Humidity is fatal for electronic circuits. In humidity exposed areas, the O-rings for the electronic housing covers must be correctly placed and the covers must be completely closed by tightening them by hand until the O-rings are compressed.

Do not use tools to close the covers. Removal of the electronics cover in the field should be reduced to the minimum necessary, as each time it is removed; the circuits are exposed to the humidity. The electronic circuit is protected by a humidity proof coating, but frequent exposure to humidity may affect the protection provided. It is also important to keep the covers tightened in place. Every time they are removed, the threads are exposed to corrosion, since painting cannot protect these parts. Code-approved sealing methods should be employed on the inlet conduit the transmitter. The unused outlet connection should be plugged accordingly.

Although the transmitter is virtually insensitive to vibration, installation close to pumps, turbines or other vibrating equipment should be avoided.

Proper winterization (freeze protection) should be employed to prevent freezing within the measuring chamber, since this will result in an inoperative transmitter and could even damage the cell.

Mounting

NOTE
When installing or storing the transmitter, the diaphragm must be protected to avoid scratching-denting or perforation of its surface.

The transmitter has been designed to be heavy duty and lightweight at the same time. This makes its mounting easier; mounting positions are shown in Figure 1.1.

Existing standards for the manifolds have also been considered, and standard designs fit perfectly to the transmitter flanges.

If the process fluid contains solids in suspension, install valves or rod-out fittings at regular intervals to clean out the pipes.

The pipes should be internally cleaned by using steam or compressed air, or by draining the line with the process fluid, before such lines are connected to the transmitter (blow-down). Do not allow steam in the measuring chamber.

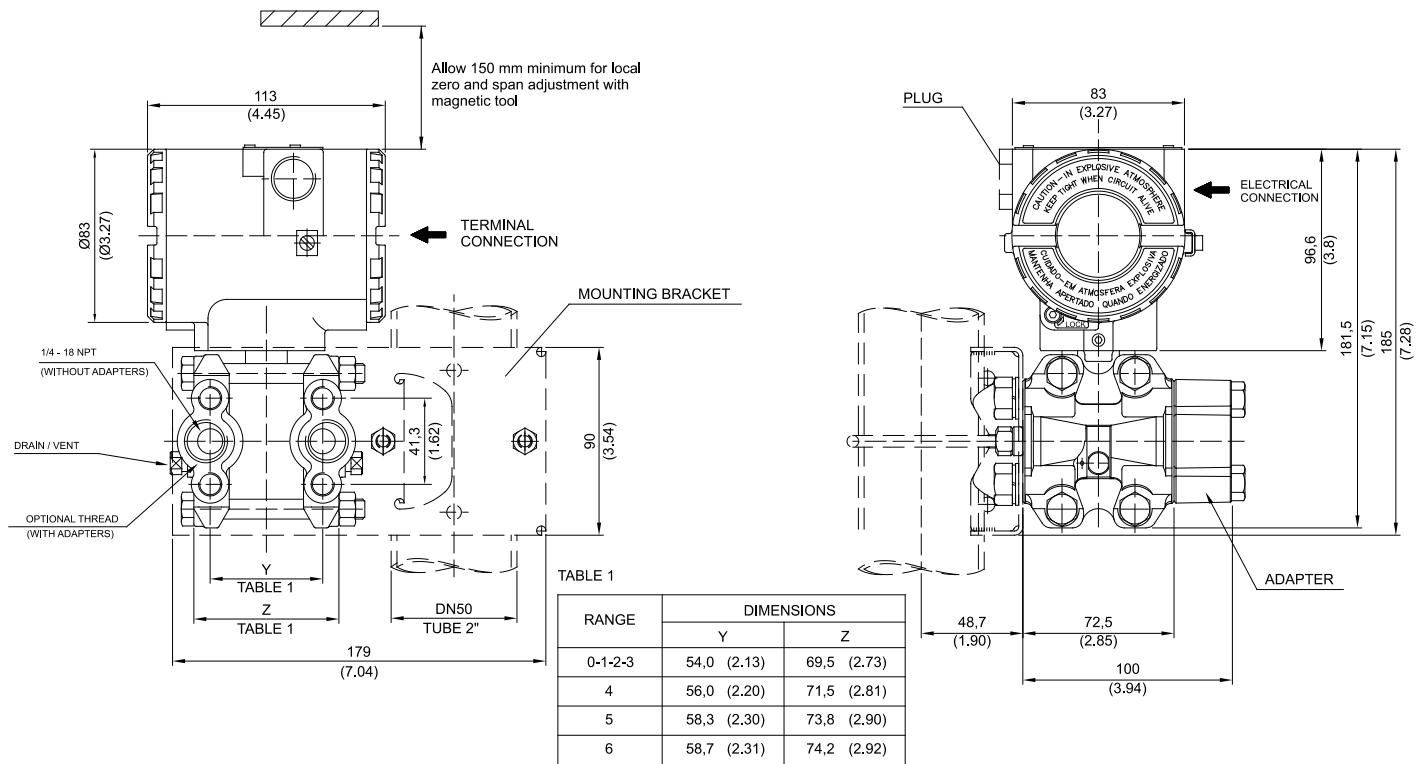
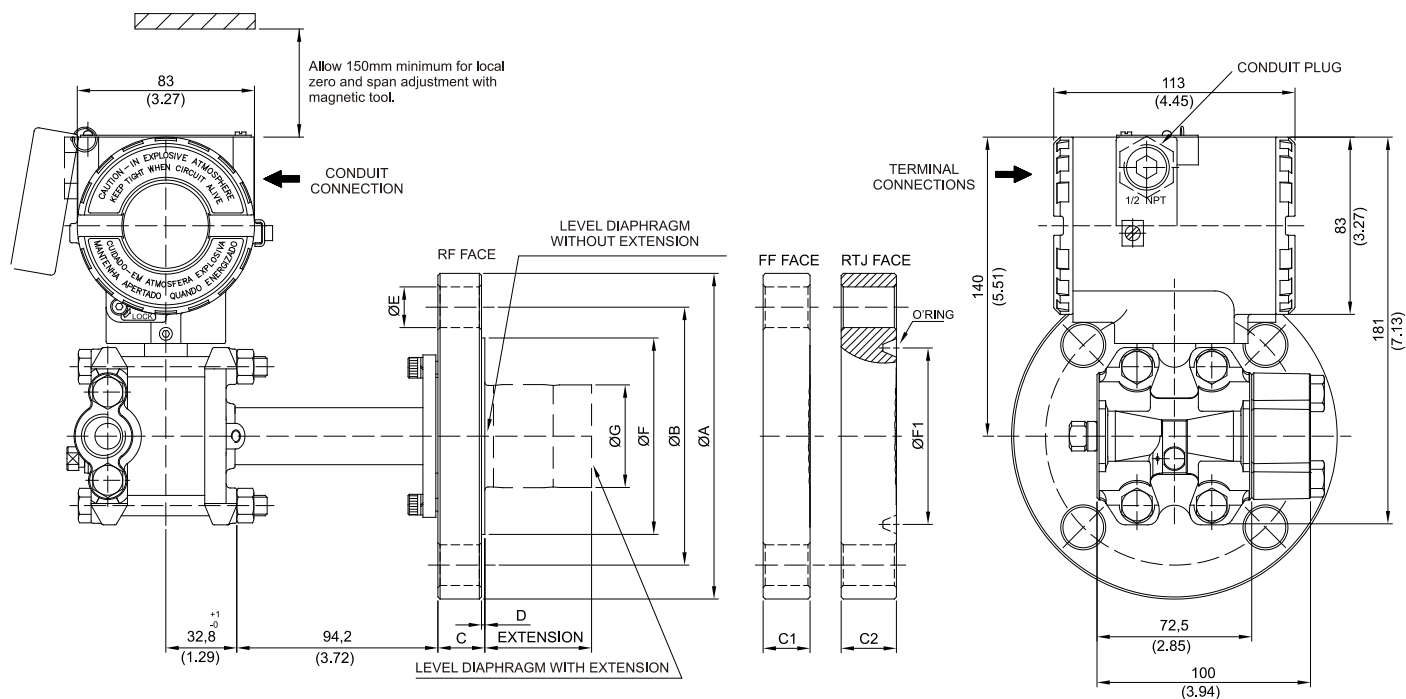

Figure 1.1 (a) – Dimensional Drawing and Mounting Position - Differential, Flow, Gage, Absolute and High Static Pressure Transmitters with Mounting Bracket



- Notes:
 - Extension length (mm): 0, 50, 100, 150 or 200
 - Dimensions are mm (in)

ANSI-B 16.5 DIMENSIONS													
DN	CLASS	A	B	C (RF)	C1 (FF)	C2 (RTJ)	D (RF)	E	F (RF)	F1 (RTJ)	RTJ O'RING	G	HOLES
1.1/2"	150	127 (5)	98.6 (3.88)	20 (0.78)	19 (0.75)	24.4 (0.96)	1.6 (0.06)	16 (0.63)	73.2 (2.88)	65.1 (2.56)	R19	40 (1.57)	4
	300	155.4 (6.12)	114.3 (4.5)	21 (0.83)	21 (0.83)	27.4 (1.07)	1.6 (0.06)	22 (0.87)	73.2 (2.88)	68.3 (2.68)	R20	40 (1.57)	4
	600	155.4 (6.12)	114.3 (4.5)	29.3 (1.15)	29.3 (1.15)	29.3 (1.15)	6.4 (0.25)	22 (0.87)	73.2 (2.88)	68.3 (2.68)	R20	40 (1.57)	4
2"	150	152.4 (6)	120.7 (4.75)	22 (0.87)	20 (0.78)	25.9 (1.02)	1.6 (0.06)	19 (0.75)	91.9 (3.62)	82.6 (3.25)	R22	48 (1.89)	4
	300	165.1 (6.5)	127 (5)	22.8 (0.9)	22.8 (0.89)	30.8 (1.21)	1.6 (0.06)	19 (0.75)	91.9 (3.62)	82.6 (3.25)	R23	48 (1.89)	8
	600	165.1 (6.5)	127 (5)	32.3 (1.27)	32.3 (1.27)	32.3 (1.27)	6.4 (0.25)	19 (0.75)	91.9 (3.62)	82.6 (3.25)	R23	48 (1.89)	8
3"	150	190.5 (7.5)	152.4 (6)	24.4 (0.96)	24.4 (0.96)	30.7 (1.21)	1.6 (0.06)	19 (0.75)	127 (5)	114.3 (4.50)	R29	73 (2.87)	4
	300	209.5 (8.25)	168.1 (6.62)	29 (1.14)	29 (1.14)	36.9 (1.45)	1.6 (0.06)	22 (0.87)	127 (5)	123.8 (4.87)	R31	73 (2.87)	8
	600	209.5 (8.25)	168.1 (6.62)	38.7 (1.52)	38.7 (1.52)	40.2 (1.58)	6.4 (0.25)	22 (0.87)	127 (5)	123.8 (4.87)	R31	73 (2.87)	8
4"	150	228.6 (9)	190.5 (7.5)	24.4 (0.96)	24.4 (0.96)	30.7 (1.21)	1.6 (0.06)	19 (0.75)	158 (6.22)	149.2 (5.87)	R36	96 (3.78)	8
	300	254 (10)	200 (7.87)	32.2 (1.27)	32.2 (1.27)	40.2 (1.58)	1.6 (0.06)	22 (0.87)	158 (6.22)	149.2 (5.87)	R37	96 (3.78)	8
	600	273 (10.75)	215.9 (8.5)	45 (1.77)	45 (1.77)	46.5 (1.83)	6.4 (0.25)	25 (1)	158 (6.22)	149.2 (5.87)	R37	96 (3.78)	8
EN 1092-1 DIMENSIONS													
DN	PN	A	B	C (RF)	C1 (FF)		D	E	F (RF)			G	HOLES
DN40	10/40	150 (5.9)	110 (4.33)	20 (0.78)	20 (0.78)		3 (0.12)	18 (0.71)	88 (3.46)			40 (1.57)	4
DN50	10/40	165 (6.5)	125 (4.92)	20 (0.78)	22 (0.86)		3 (0.12)	18 (0.71)	102 (4.01)			48 (1.89)	4
DN80	10/40	200 (7.87)	160 (6.3)	24 (0.95)	24 (0.94)		3 (0.12)	18 (0.71)	138 (5.43)			73 (2.87)	8
DN100	10/16	220 (8.67)	180 (7.08)	20 (0.78)			3 (0.12)	18 (0.71)	158 (6.22)			96 (3.78)	8
	25/40	235 (9.25)	190 (7.5)	24 (0.95)			3 (0.12)	22 (0.87)	162 (6.38)			96 (3.78)	8
JIS B 2202 DIMENSIONS													
DN	CLASS	A	B	C			D	E	F (RF)			G	HOLES
40A	20K	140 (5.5)	105 (4.13)	26 (1.02)			2 (0.08)	19 (0.75)	81 (3.2)			40 (1.57)	4
50A	10K	155 (6.1)	120 (4.72)	26 (1.02)			2 (0.08)	19 (0.75)	96 (3.78)			48 (1.89)	4
	40K	165 (6.5)	130 (5.12)	26 (1.02)			2 (0.08)	19 (0.75)	105 (4.13)			48 (1.89)	8
80A	10K	185 (7.28)	150 (5.9)	26 (1.02)			2 (0.08)	19 (0.75)	126 (4.96)			73 (2.87)	8
	20K	200 (7.87)	160 (6.3)	26 (1.02)			2 (0.08)	19 (0.75)	132 (5.2)			73 (2.87)	8
100A	10K	210 (8.27)	175 (6.89)	26 (1.02)			2 (0.08)	19 (0.75)	151 (5.95)			96 (3.78)	8

Figure 1.1 (b) – Dimensional Drawing and Mounting Position - Flanged Pressure Transmitter with Integral Flange

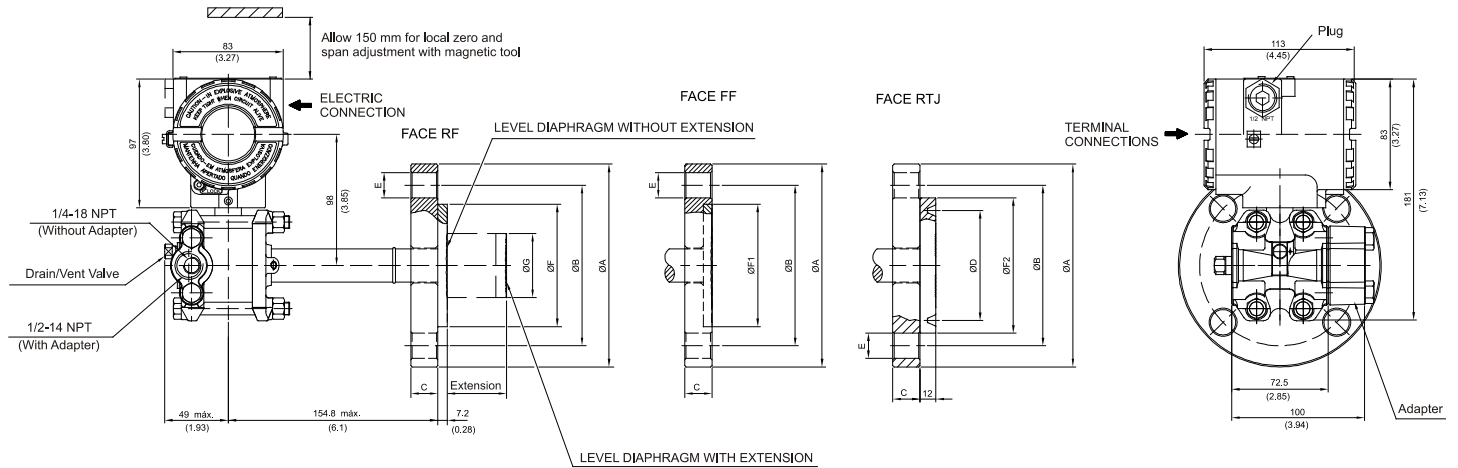

ANSI-B 16.5 DIMENSIONS												
DN	CLASS	A	B	C	D	E	F (RF)	F1 (FF)	F2 (RTJ)	G	HOLES	
1"	150	108 (4.25)	79.4 (3.16)	14.3 (0.56)	-	16 (0.63)	50.8 (2)	50.8 (2)	-	-	4	
	300/600	124 (4.88)	88.9 (3.5)	17.5 (0.69)	-	19 (0.75)	50.8 (2)	50.8 (2)	-	-	4	
1 1/2"	150	127 (5)	98.4 (3.87)	17.5 (0.69)	-	16 (0.63)	73 (2.87)	73 (2.87)	-	40 (1.57)	4	
	300/600	156 (6.14)	114.3 (4.5)	22.2 (0.87)	-	22 (0.87)	73 (2.87)	73 (2.87)	-	40 (1.57)	4	
2"	150	152.4 (6)	120.7 (4.75)	17.5 (0.69)	82.6 (3.25)	19 (0.75)	92 (3.62)	92 (3.62)	101.6 (4.00)	48 (1.89)	4	
	300	165.1 (6.5)	127 (5)	20.7 (0.8)	82.6 (3.25)	19 (0.75)	92 (3.62)	92 (3.62)	107.9 (4.25)	48 (1.89)	8	
	600	165.1 (6.5)	127 (5)	25.4 (1)	82.6 (3.25)	19 (0.75)	92 (3.62)	92 (3.62)	107.9 (4.25)	48 (1.89)	8	
3"	150	190.5 (7.5)	152.4 (6)	22.3 (0.87)	114.3 (4.50)	19 (0.75)	127 (5)	127 (5)	133.4 (5.25)	73 (2.87)	4	
	300	209.5 (8.25)	168.1 (6.62)	27 (1.06)	123.8 (4.87)	22 (0.87)	127 (5)	127 (5)	146.1 (5.75)	73 (2.87)	8	
	600	209.5 (8.25)	168.1 (6.62)	31.8 (1.25)	123.8 (4.87)	22 (0.87)	127 (5)	127 (5)	146.1 (5.75)	73 (2.87)	8	
4"	150	228.6 (9)	190.5 (7.5)	22.3 (0.87)	149.2 (5.87)	19 (0.75)	158 (6.22)	158 (6.22)	171.5 (6.75)	89 (3.5)	8	
	300	254 (10)	200 (7.87)	30.2 (1.18)	149.2 (5.87)	22 (0.87)	158 (6.22)	158 (6.22)	174.6 (6.87)	89 (3.5)	8	
	600	273 (10.75)	215.9 (8.5)	38.1 (1.5)	149.2 (5.87)	25 (1)	158 (6.22)	158 (6.22)	174.6 (6.87)	89 (3.5)	8	

EN 1092-1 / DIN2501 DIMENSIONS - RF/ FF									
DN	PN	A	B	C	E	F	G	HOLES	
25	10/40	115 (4.53)	85 (3.35)	18 (0.71)	14 (0.55)	68 (2.68)	-	4	
40	10/40	150 (5.91)	110 (4.33)	18 (0.71)	18 (0.71)	88 (3.46)	73 (2.87)	4	
50	10/40	165 (6.50)	125 (4.92)	20 (0.78)	18 (0.71)	102 (4.01)	48 (1.89)	4	
80	10/40	200 (7.87)	160 (6.30)	24 (0.95)	18 (0.71)	138 (5.43)	73 (2.87)	8	
100	10/16	220 (8.67)	180 (7.08)	20 (0.78)	18 (0.71)	158 (6.22)	89 (3.5)	8	
	25/40	235 (9.25)	190 (7.50)	24 (0.95)	22 (0.87)	162 (6.38)	89 (3.5)	8	

NOTES:
 -EXTENSION LENGTH IN mm(in): 0, 50 (1.96), 100 (3.93), 150(5.9) or 200 (7.87)
 -DIMENSIONS IN mm(in)

Figure 1.1 (c) – Dimensional Drawing and Mounting Position - Flanged Pressure Transmitter with Slip-on Flange

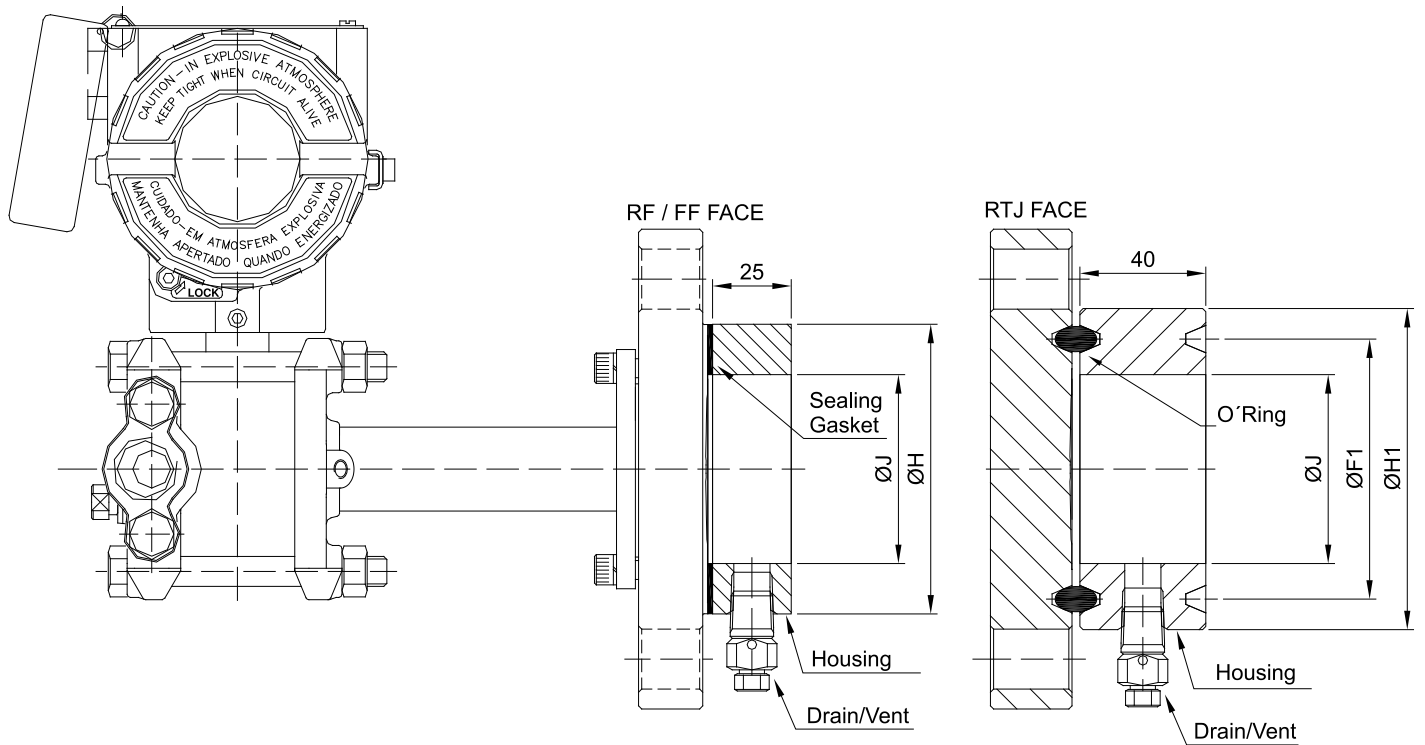

DIMENSIONS IN mm (")

ANSI-B 16.5 DIMENSIONS			
DN	CLASS	H	J
1.1/2"	ALL	73,2 (2,88)	48 (1,89)
2"		91,9 (3,62)	60 (2,36)
3"		127 (5,00)	89 (3,50)
4"		158 (6,22)	115 (4,53)
DIN EN1092-1/ DIN2501/2526 FORM D DIMENSIONS			
DN	PN	H	J
40	ALL	88 (3,46)	48 (1,89)
50		102 (4,02)	60 (2,36)
80		138 (5,43)	89 (3,50)
100		158 (6,22)	115 (4,53)
JIS B 2202 DIMENSIONS			
DN	CLASS	H	J
40A	20K	81 (3,19)	48 (1,89)
50A	10K	96 (3,78)	60 (1,36)
	40K	105 (4,13)	60 (1,36)
80A	10K	126 (4,96)	89 (3,50)
	20K	132 (5,20)	89 (3,50)
100A	10K	151 (5,94)	115 (4,53)

DIMENSIONS IN mm (")

ANSI-B 16.5 DIMENSIONS - RTJ FACE					
DN	CLASS	F1	O RING	H1	J
1.1/2"	150	65,1 (2,56)	R19	82,5 (3,25)	48 (1,89)
	300	68,3 (2,69)	R20	90,5 (3,56)	48 (1,89)
	600	68,3 (2,69)	R20	90,5 (3,56)	48 (1,89)
	1500	68,3 (2,69)	R20	92 (3,62)	48 (1,89)
2"	2500	82,6 (3,25)	R23	114 (4,50)	48 (1,89)
	150	82,6 (3,25)	R22	102 (4,00)	60 (2,36)
	300	82,6 (3,25)	R23	108 (4,25)	60 (2,36)
	600	82,6 (3,25)	R23	108 (4,25)	60 (2,36)
	1500	95,3 (3,75)	R24	124 (4,88)	60 (2,36)
3"	2500	101,6 (4,00)	R26	133 (5,25)	60 (2,36)
	150	114,3 (4,50)	R29	133 (5,25)	89 (3,50)
	300	123,8 (4,87)	R31	146 (5,75)	89 (3,50)
4"	600	123,8 (4,87)	R31	146 (5,75)	89 (3,50)
	150	149,2 (5,87)	R36	171 (6,75)	115 (4,53)
	300	149,2 (5,87)	R37	175 (6,88)	115 (4,53)
	600	149,2 (5,87)	R37	175 (6,88)	115 (4,53)

Figure 1.1 (d) – Dimensional Drawing and Mounting Position - Flanged Pressure Transmitter with Housing

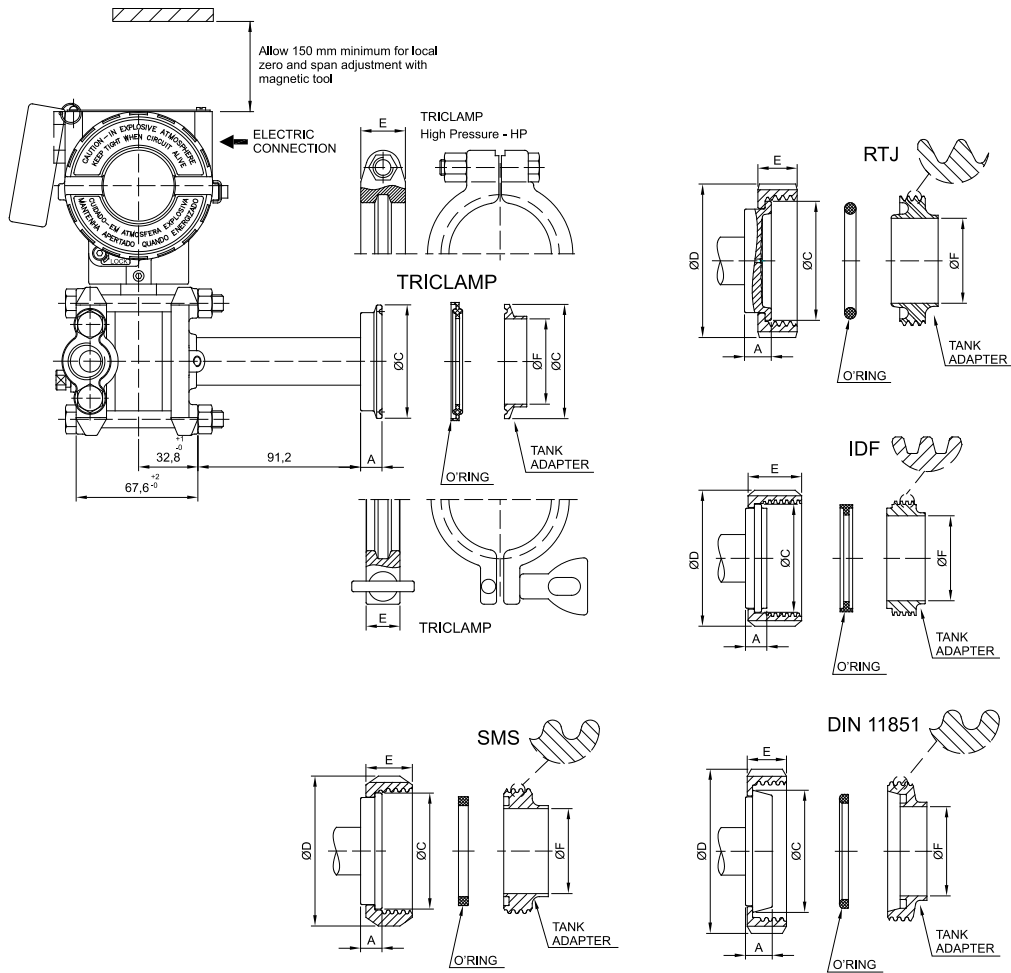

LD300S							
CONNECTION WITHOUT EXTENSION	Dimensions in mm (")						
	A	ØC	ØD	E	ØF	ØG	EXT.
Tri-Clamp DN50	8 (0.315)	63.5 (2.5)	76.5 (3.01)	18 (0.71)	47.5 (1.87)	--	--
Tri-Clamp - 1 1/2"	12 (0.47)	50 (1.96)	61 (2.4)	18 (0.71)	35 (1.38)	--	--
Tri-Clamp - 1 1/2" HP	12 (0.47)	50 (1.96)	66 (2.59)	25 (0.98)	35 (1.38)	--	--
Tri-Clamp - 2"	12 (0.47)	63.5 (2.5)	76.5 (3.01)	18 (0.71)	47.6 (1.87)	--	--
Tri-Clamp - 2" HP	12 (0.47)	63.5 (2.5)	81 (3.19)	25 (0.98)	47.6 (1.87)	--	--
Tri-Clamp - 3"	12 (0.47)	91 (3.58)	110 (4.33)	18 (0.71)	72 (2.83)	--	--
Tri-Clamp - 3" HP	12 (0.47)	91 (3.58)	115 (4.53)	25 (0.98)	72 (2.83)	--	--
Threaded DN40 - DIN 11851	13 (0.51)	56 (2.2)	78 (3.07)	21 (0.83)	38 (1.5)	--	--
Threaded DN50 - DIN 11851	15 (0.59)	68.5 (2.7)	92 (3.62)	22 (0.86)	50 (1.96)	--	--
Threaded DN80 - DIN 11851	16 (0.63)	100 (3.94)	127 (5)	29 (1.14)	81 (3.19)	--	--
Threaded SMS - 1 1/2"	12 (0.47)	55 (2.16)	74 (2.91)	25 (0.98)	35 (1.38)	--	--
Threaded SMS - 2"	12 (0.47)	65 (2.56)	84 (3.3)	26 (1.02)	48.6 (1.91)	--	--
Threaded SMS - 3"	12 (0.47)	93 (3.66)	113 (4.45)	32 (1.26)	73 (2.87)	--	--
Threaded RJT - 2"	15 (0.59)	66.7 (2.63)	86 (3.38)	22 (0.86)	47.6 (1.87)	--	--
Threaded RJT - 3"	15 (0.59)	92 (3.62)	112 (4.41)	22.2 (0.87)	73 (2.87)	--	--
Threaded IDF - 2"	12 (0.47)	60.5 (2.38)	76 (2.99)	30 (1.18)	47.6 (1.87)	--	--
Threaded IDF - 3"	12 (0.47)	87.5 (3.44)	101.6 (4)	30 (1.18)	73 (2.87)	--	--

Figure 1.1 (e) – Dimensional Drawing and Mounting Position - Sanitary Transmitter without Extension

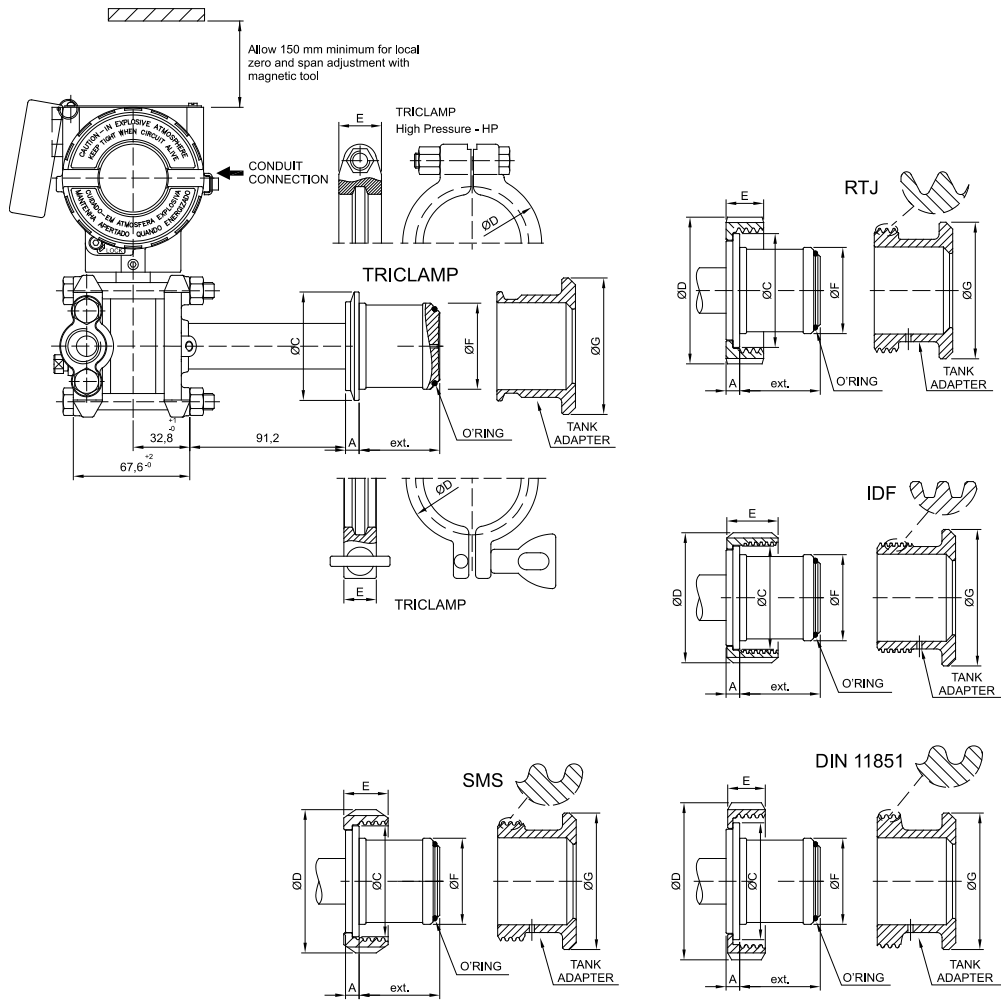

LD300S							
CONNECTION WITH EXTENSION	Dimensions in mm (")						
	A	ØC	ØD	E	ØF	ØG	EXT.
Tri-Clamp DN50	8 (0.315)	63.5 (2.5)	76.5 (3.01)	18 (0.71)	50.5 (1.99)	80 (3.15)	48 (1.89)
Tri-Clamp DN50 HP	8 (0.315)	63.5 (2.5)	81 (3.19)	25 (0.98)	50.5 (1.99)	80 (3.15)	48 (1.89)
Tri-Clamp - 2"	8 (0.315)	63.5 (2.5)	76.5 (3.01)	18 (0.71)	50.5 (1.99)	80 (3.15)	48 (1.89)
Tri-Clamp - 2" HP	8 (0.315)	63.5 (2.5)	81 (3.19)	25 (0.98)	50.5 (1.99)	80 (3.15)	48 (1.89)
Tri-Clamp - 3"	8 (0.315)	91 (3.58)	110 (4.33)	18 (0.71)	72.5 (2.85)	100 (3.94)	50 (1.96)
Tri-Clamp - 3" HP	8 (0.315)	91 (3.58)	115 (4.53)	25 (0.98)	72.5 (2.85)	100 (3.94)	50 (1.96)
Threaded DN25 - DIN 11851	6 (0.24)	47.5 (1.87)	63 (2.48)	21 (0.83)	43.2 (1.7)	80 (3.15)	26.3 (1.03)
Threaded DN40 - DIN 11851	8 (0.315)	56 (2.2)	78 (3.07)	21 (0.83)	50.5 (1.99)	80 (3.15)	48 (1.89)
Threaded DN50 - DIN 11851	8 (0.315)	68.5 (2.7)	92 (3.62)	22 (0.86)	50.5 (1.99)	80 (3.15)	48 (1.89)
Threaded DN80 - DIN 11851	8 (0.315)	100 (3.94)	127 (5)	29 (1.14)	72.5 (2.85)	100 (3.94)	50 (1.96)
Threaded SMS - 2"	8 (0.315)	65 (2.56)	84 (3.3)	26 (1.02)	50.5 (1.99)	80 (3.15)	48 (1.89)
Threaded SMS - 3"	8 (0.315)	93 (3.66)	113 (4.45)	32 (1.26)	72.5 (2.85)	100 (3.94)	50 (1.96)
Threaded RJT - 2"	8 (0.315)	66.7 (2.63)	86 (3.38)	22 (0.86)	50.5 (1.99)	80 (3.15)	48 (1.89)
Threaded RJT - 3"	8 (0.315)	92 (3.62)	112 (4.41)	22.2 (0.87)	72.5 (2.85)	100 (3.94)	50 (1.96)
Threaded IDF - 2"	8 (0.315)	60.5 (2.38)	76.2 (3)	30 (1.18)	50.5 (1.99)	80 (3.15)	48 (1.89)
Threaded IDF - 3"	8 (0.315)	87.5 (3.44)	101.6 (4)	30 (1.18)	72.5 (2.85)	100 (3.94)	50 (1.96)

Figure 1.1 (f) – Dimensional Drawing and Mounting Position - Sanitary Transmitter with Extension

Follow operating safety rules during wiring, draining or blow-down.

Some examples of installation, illustrating the position of the transmitter according to the taps, are shown in Figure 1.3 - Position of the Transmitter and Taps. The location of pressure taps and the relative position of the transmitter are indicated in Table 1.1 - Location of Pressure Taps.

Process Fluid	Location of Taps	Best Location for the LD302 in Relation to the Taps
Gas	Top or Side	Above the Taps
Liquid	Side	Below the Taps or at the Piping Centerline
Steam	Side	Below the Taps using Sealing (Condensate) Pots

Table 1.1 - Location of Pressure Taps

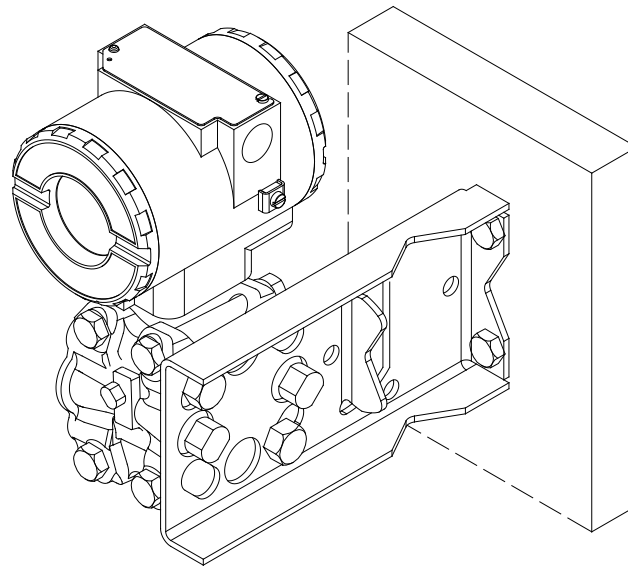

WALL OR PANEL MOUNTING
(See section 5 – spare parts list for mounting brackets available)

Figure 1.2 - Dimensional Drawing and Mounting Position for LD302

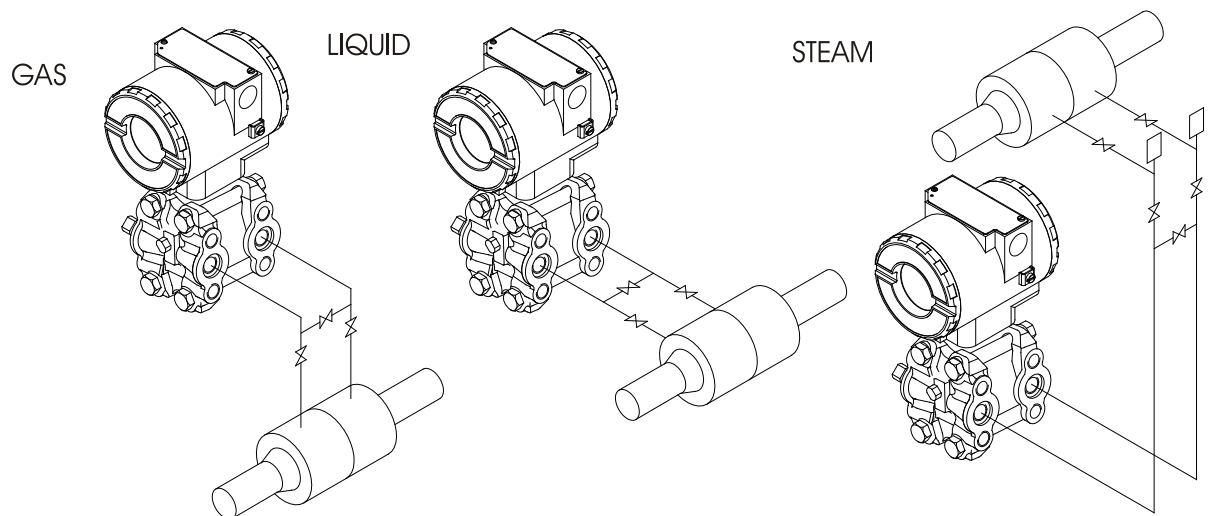

Figure 1.3 - Position of the Transmitter and Taps

NOTE

Except for dry gases, all impulse lines should slope at the ratio 1:10, in order to avoid trapping bubbles in the case of liquids, or condensation from steam or wet gases.

Housing Rotation

The housing can be rotated in order to get the digital display in better position. To rotate it, releases the Housing Rotation Set Screw see Figure 1.4. The digital display itself can also be rotated. See Figure 4.3

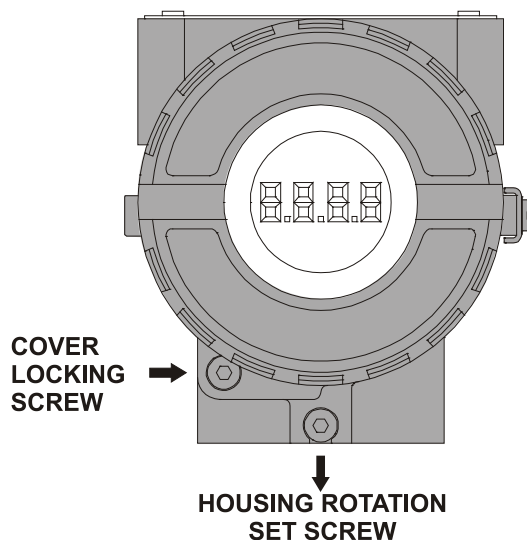

Figure 1.4 - Housing Rotation Set Screw

Reach the wiring block by removing the Electrical Connection Cover. This cover can be locked closed by the cover locking screw. See Figure 1.5. To release the cover, rotate the locking screw clockwise.

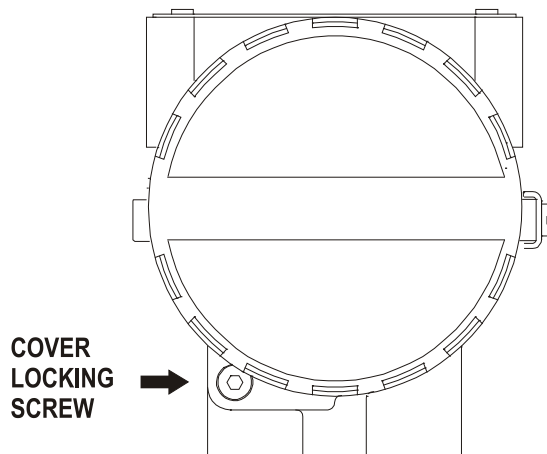

Figure 1.5 - Housing Rotation Set Screw

The wiring block has screws on which fork or ring-type terminals can be fastened. Also, for convenience there are three ground terminals: one inside the cover and two externals, located close to the conduit entries. See Figure 1.6.

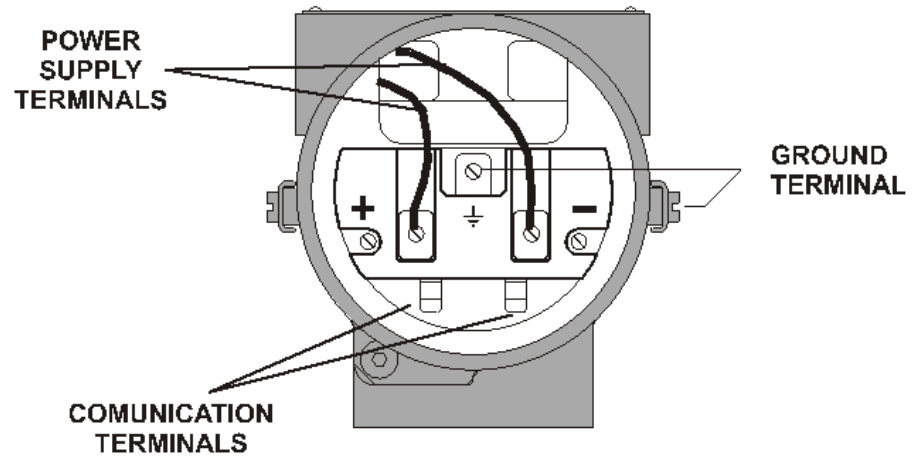

Figure 1.6 - Terminal Block

NOTE

Please refer to the General Installation, Operation and Maintenance Manual for more details.

The Figure 1.7 shows the correct installation of the conduit, in order to avoid penetration of water, or other substance, which may cause malfunctioning of the equipment.

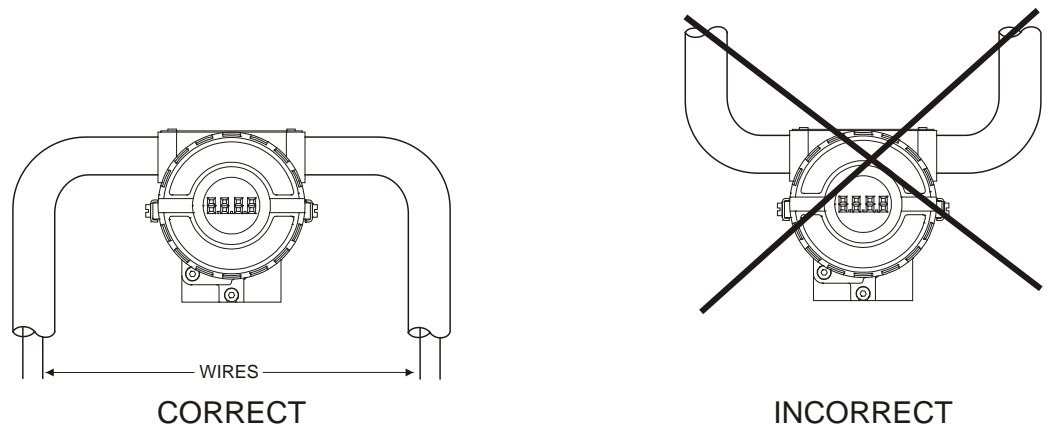

Figure 1.7 - Conduit Installation Diagram

NOTE

The transmitters are calibrated in the vertical position and a different mounting position displaces the zero point. In these conditions, it is recommended to do the zero pressure trim. The zero trim is to compensate the final assembly position and its performance, when the transmitter is in its final position. When the zero trim is executed, make sure the equalization valve is open and the wet leg levels are correct.

For the absolute pressure transmitter, the assembly effects correction should be done using the Lower trim, due to the fact that the absolute zero, is the reference for these transmitters, so there is no need for a zero value for the Lower trim.

When the sensor is in the horizontal position, the weight of the fluid pushes the diaphragm down, making it necessary a Lower Pressure. Trim see figure 1.8.

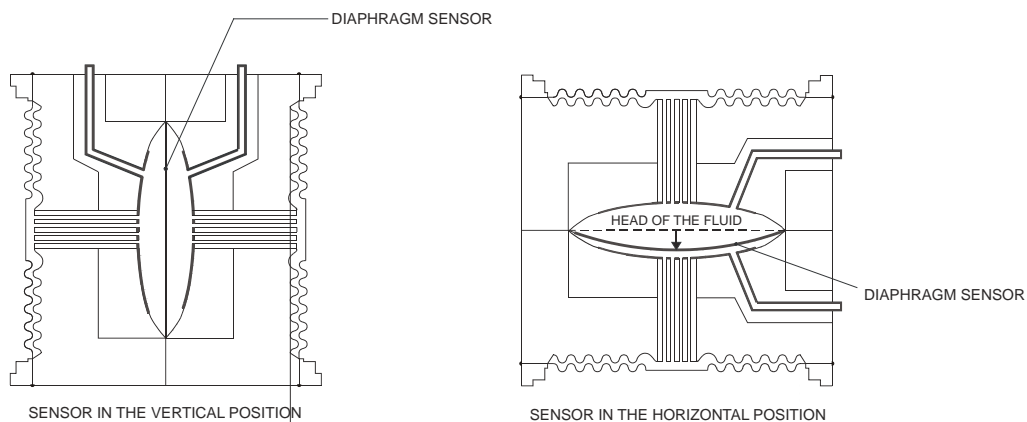

Figure 1.8 - Sensor Positions

Bus and Tree Topology and Network Configuration

The **LD302** uses the 31.25 kbit/s voltage mode option for the physical signaling. All other devices on the same bus must use the same signaling. All devices are connected in parallel along the same pair of wires.

Many types of Fieldbus devices may be connected on the same bus.

The **LD302** is powered via the bus. The limit for such devices is 16 for one bus for non-intrinsically safe requirement.

In hazardous area, the number of devices may be limited by intrinsically safe restrictions.

The **LD302** is protected against reverse polarity, and can withstand ± 35 V_{dc} without damage. However it will not work in this situation.

Connection of the **LD302** working in bus topology is in Figure 1.9.

Connection of the **LD302** working in tree topology is in Figure 1.10.

The connection of couplers should be kept at less than 15 per 250 m.

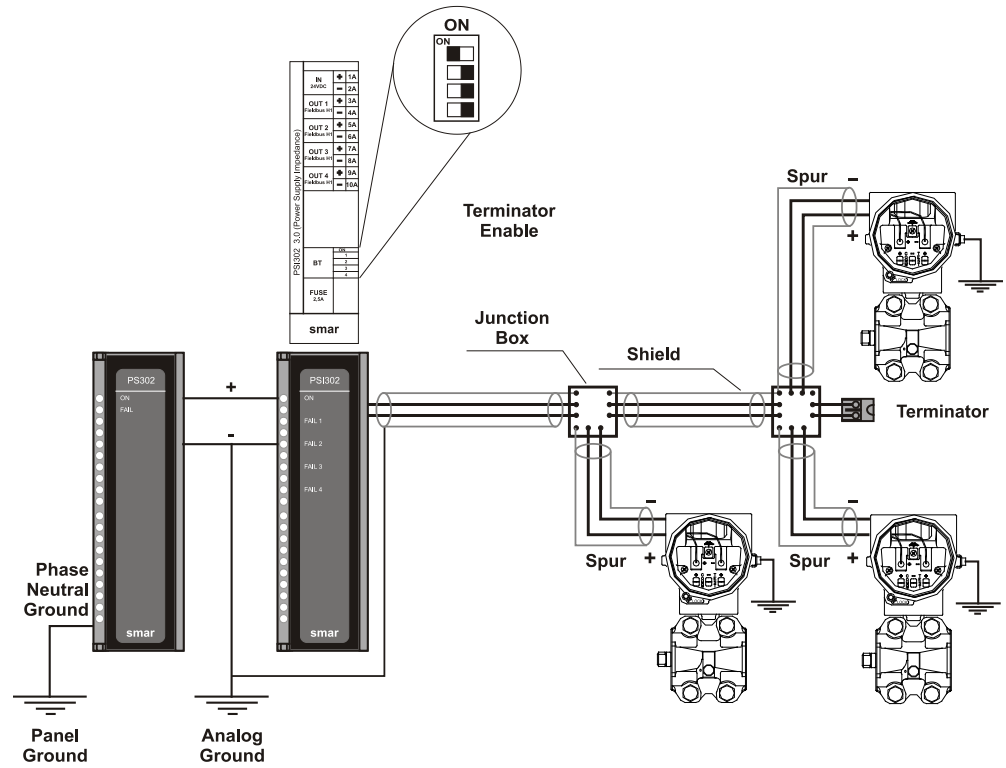

Figure 1.9 - Bus Topology

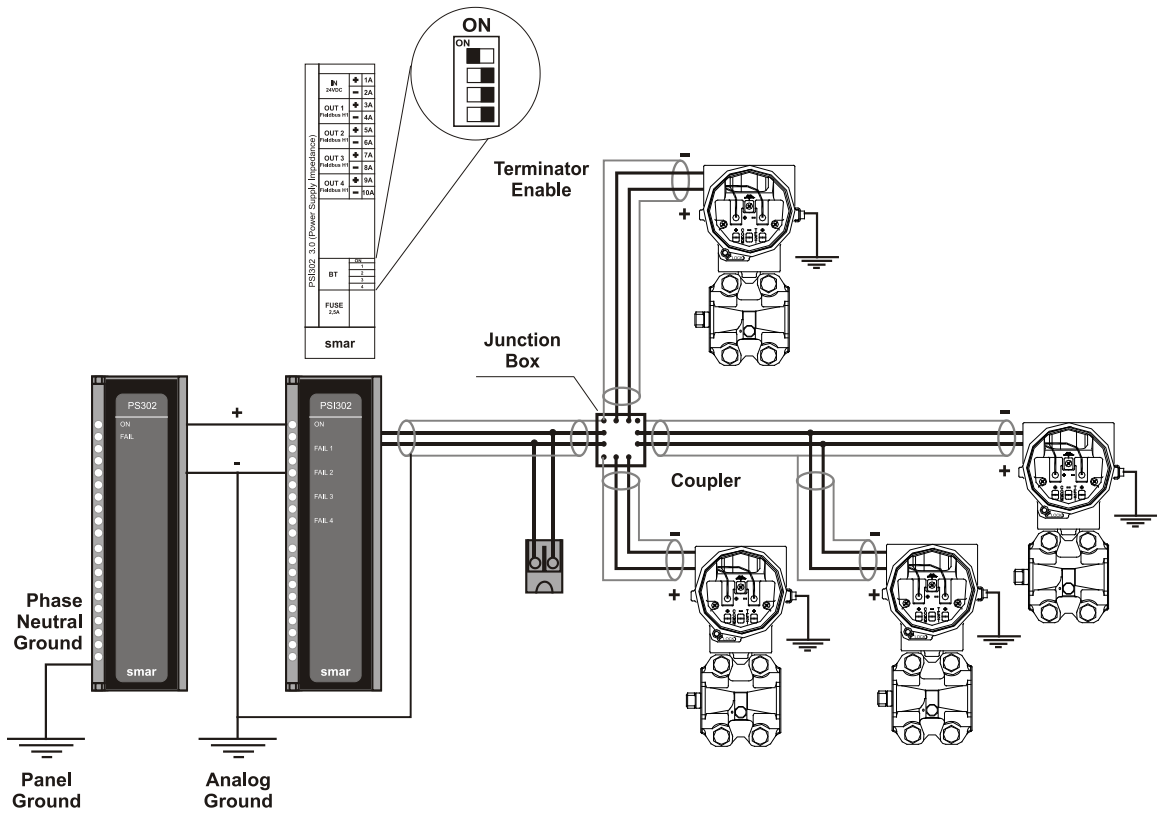

Figure 1.10 -Tree Topology

Installation in Hazardous Areas

WARNING

Explosions could result in death or serious injury, besides financial damage. Installation of this transmitter in explosive areas must be carried out in accordance with the local standards and the protection type adopted. Before continuing the installation make sure the certificate parameters are in accordance with the classified area where the equipment will be installed.

The instrument modification or parts replacement supplied by other than authorized representative of Smar is prohibited and will void the certification.

The transmitters are marked with options of the protection type. The certification is valid only when the protection type is indicated by the user. Once a particular type of protection is selected, any other type of protection can not be used.

The electronic housing and the sensor installed in hazardous areas must have a minimum of 6 fully engaged threads. Lock the housing using the locking screw (Figure 1.4).

The cover must be tighten with at least 8 turns to avoid the penetration of humidity or corrosive gases. The cover must be tighten until it touches the housing. Then, tighten more 1/3 turn (120°) to guarantee the sealing. Lock the covers using the locking screw (Figure 1.4).

Consult the Appendix A for further information about certification.

Explosion/Flame Proof

WARNING

Only use Explosion Proof/Flameproof certified Plugs, Adapters and Cable glands.

In Explosion-Proof installations the cable entries must be connected or closed using metal cable gland and metal blanking plug, both with at least IP66 and Ex-d certification.

The standard plugs provided by Smar are certified according to CEPEL certificate. If the plug needs to be replaced, a certified plug must be used.

The electrical connection with NPT thread must use waterproofing sealant. A non-hardening silicone sealant is recommended.

For NEMKO ATEX certificate please to follow the installation guidelines in hazardous locations below: Group II Category 2G, Ex d, Group IIC, Temperature Class T6, EPL Gb U = 28VDC
Ambient Temperature: -20 to 60°C for T6
Environmental Protection: IP66/687 or IP66W/687W
The electrical connection available are ½ - 14NPT and M20x1,5.

Cable entries must be connected or closed using metal cable gland and metal blanking plug, both with at least IP66 and Ex-d certification or any appropriate ATEX approved metal cable gland and metal blanking plug. Do not remove the transmitter covers when power is ON.

Intrinsically Safe

WARNING

In hazardous zones with intrinsically safe or non-incendive requirements, the circuit entity parameters and applicable installation procedures must be observed.

To protect the application the transmitter must be connected to a barrier. Match the parameters between barrier and the equipment (Consider the cable parameters). Associated apparatus ground bus shall be insulated from panels and mounting enclosures. Shield is optional. If used, be sure to insulate the end not grounded. Cable capacitance and inductance plus C_i and L_i must be smaller than C_o and L_o of the associated Apparatus.

It is not recommended to remove the transmitter cover when the power is ON.

OPERATION

The LD302 Series Pressure Transmitters use capacitive sensors (capacitive cells) as pressure sensing elements, as shown in Figure 2.1. This is the same sensor that is used in the LD301 series, the sensor modules are therefore interchangeable.

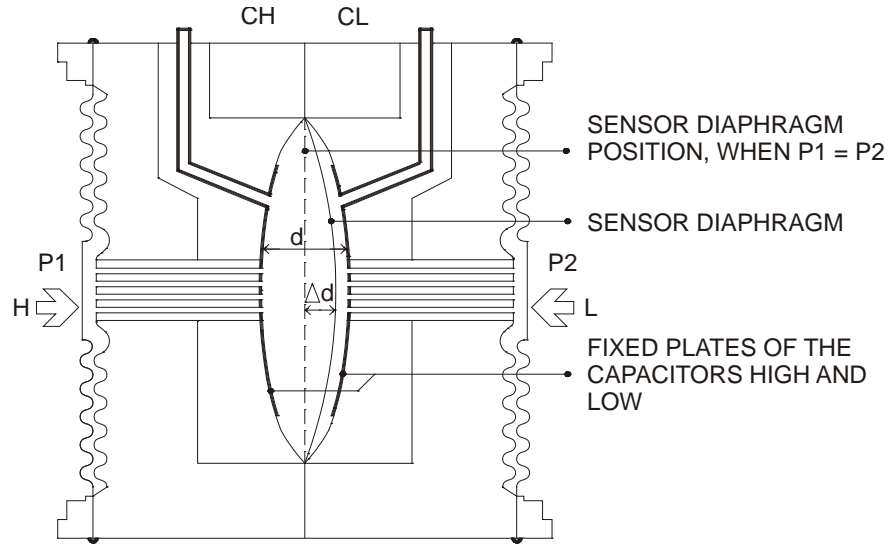

Figure 2.1 - Capacitive Cell

Functional Description - Sensor

Where,

P_1 and P_2 are the pressures and $P_1 \geq P_2$

CH = Capacitance between the fixed plate on P_1 side and the sensing diaphragm.

CL = Capacitance between the fixed plate on the P_2 side and the sensing diaphragm.

d = Distance between CH and CL fixed plates.

Δd = Sensing diaphragm's deflection due to the differential pressure $\Delta P = P_1 - P_2$.

Knowing that the capacitance of a capacitor with flat, parallel plates may be expressed as a function of plate area (A) and distance (d) between the plates:

$$C \approx \frac{\epsilon \times A}{d}$$

Where,

ϵ = Dielectric constant of the medium between the capacitor's plates.

$$CH \approx \frac{\epsilon \times A}{(d/2) + \Delta d} \quad \text{and} \quad \frac{\epsilon \times A}{(d/2) - \Delta d} \approx CL$$

The CH and CL should be considered as capacitances of flat and parallel plates with identical areas, however, should the differential pressure (ΔP) applied to the capacitive cell not deflect the sensing diaphragm beyond $d/4$, it is possible to assume ΔP as proportional to Δd , that is:

$$\Delta P \propto \Delta d$$

By developing the expression $(CL - CH)/(CL + CH)$, it follows that:

$$\frac{CL - CH}{CL + CH} = \frac{2\Delta d}{d}$$

Though distance (d) between the fixed plates CH and CL is constant. It is possible to conclude that the expression $(CL - CH)/(CL + CH)$ is proportional to Δd and therefore, to the differential pressure to be measured.

Thus, it is possible to conclude that the capacitive cell is a pressure sensor formed by two capacitors whose capacitances vary according to the applied differential pressure.

Functional Description – Electronics

Refer to the block diagram Figure 2.2 - LD302 Block Diagram Hardware. The function of each block is described below.

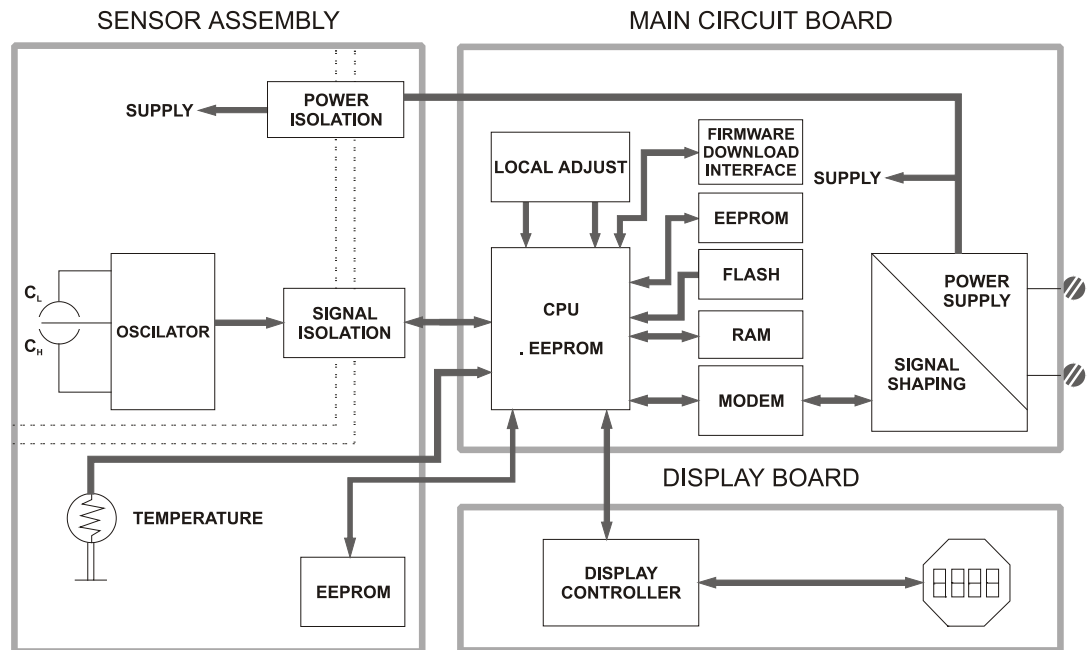

Figure 2.2 - LD302 Block Diagram Hardware

Oscillator

This oscillator generates a frequency as a function of sensor capacitance.

Signal Isolator

The control signals from the CPU and the signal from the oscillator are isolated to avoid ground loops.

Central Processing Unit (CPU), RAM, FLASH and EEPROM

The CPU is the intelligent portion of the transmitter; it is responsible for the management and operation of measurement, block execution, self-diagnostics and communication. The program is stored in a FLASH memory for easy upgrade and saves the data in case of a power down. For temporary storage of data there is a RAM. The data in the RAM is lost if the power is switched off, however the main board has a nonvolatile EEPROM memory where the static data configured that must be retained is stored. Examples of such data are the following: calibration, links and identification data.

Sensor EEPROM

Another EEPROM is located within the sensor assembly. It contains data pertaining to the sensor's characteristics at different pressures and temperatures. This characterization is done for each sensor at the factory. It also contains the factory settings; they are useful in case of main board replacement, when it does an automatic upload of data from the sensor board to main board.

Fieldbus Modem

Monitors line activity, modulates and demodulates communication signals, inserts and deletes start and end delimiters, and checks integrity of frame received.

Power Supply

Takes power from the loop-line to power the transmitter circuitry.

Power Isolation

Isolates the signals from the input section, the power to the input section must be isolated.

Display Controller

Receives data from the CPU, identifying which segments on the liquid crystal Display to turn on. The controller drives the display background and the segment control signals.

Local Adjustment

There are two switches that are magnetically activated. A magnetic tool without mechanical or electrical contact can activate them.

The Display

The integral indicator can display one or two variables, which are user selectable. When two variables are chosen, the display will alternate within an interval of 3 seconds.

The liquid crystal display includes a 4 ½ numeric digits field, a 5 alphanumeric digits field and an information field, as shown in Figure 2.3.

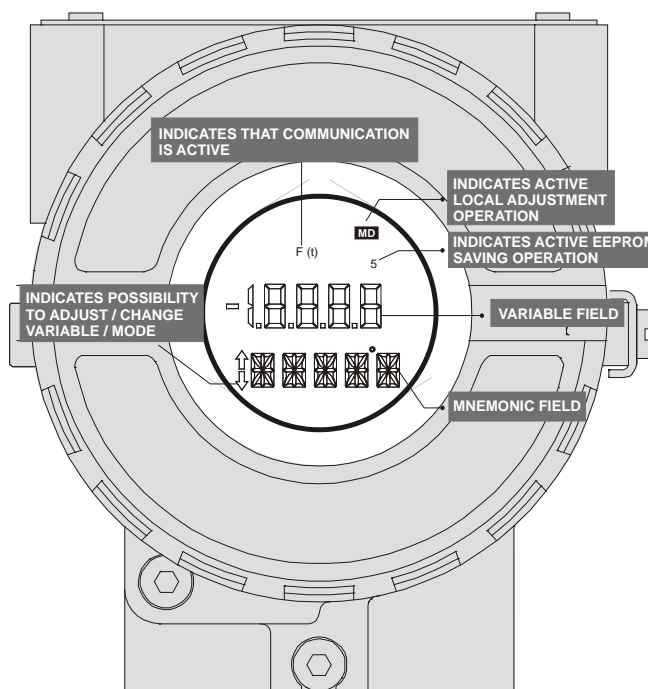

Figure 2.3 - LCD Indicator

Section 3

CONFIGURATION

One of the many advantages of Fieldbus is that device configuration does not depend on the configurator since the technology works with device descriptions and the interoperability concepts. The **LD302** may be configured from a third party terminal or an operator console. A particular configurator is therefore not addressed here.

This section describes the characteristics of the blocks in the **LD302**. They follow the Fieldbus specifications, but as for of transducer blocks, the input transducer block and display, they have other special features.

Transducer Block

The transducer block insulates the function blocks from the specific I/O hardware, such as sensors or actuators. The transducer block controls access to the I/O through the manufacturer specific implementation. This allows the transducer block to be executed as frequently as necessary to obtain good data from sensors without burdening the function blocks that use the data. It also insulates the function block from the manufacturer specific characteristics of certain hardware.

By accessing the hardware, the transducer block can get data from the I/O or pass control data to it. The connection between a Transducer block and a Function block is called a channel. These blocks can exchange data from their interface.

Usually, the transducer blocks perform functions, such as linearization, characterization, temperature compensation, hardware control and data exchange.

Pressure Transmitter Block Parameter Description

Parameter	Description
ST_REV	Indicates the level of static data.
TAG_DESC	Description of Transducer Block.
STRATEGY	This parameter is not checked and processed by Transducer Block.
ALERT_KEY	Number of identification in the plant.
MODE_BLK	Indicates the operation mode of Transducer Block.
BLOCK_ERR	Indicates the status associated with hardware or software in the Transducer.
UPDATE_EVT	It is the alert for any static data.
BLOCK_ALM	It is used for configuration, hardware and others fail.
TRANSDUCER_DIRECTORY	It is used to select several Transducer Blocks.
TRANSDUCER_TYPE	Indicates the type of Transducer according to its class.
XD_ERROR	It is used to indicate calibration status.
COLLECTION_DIRECTORY	Specifies the number of transducer index into Transducer Block.
PRIMARY_VALUE_TYPE	Defines the calculation type for Transducer Block.
PRIMARY_VALUE	It is the value and status used by channel.
PRIMARY_VALUE_RANGE	The High and Low range limit values, the engineering unit code and the number of digits to the right of the decimal point to be used for Primary Value.
CAL_POINT_HI	The highest calibrated value.
CAL_POINT_LO	The lowest calibrated value.
CAL_MIN_SPAN	The minimum calibration span value allowed. This minimum span information is necessary to ensure that when calibration is done, the two calibrated points (high and low) are not too close together.
CAL_UNIT	The Device Description engineering units code index for the calibration values.
SENSOR_TYPE	The type of sensor.
SENSOR_RANGE	The range of sensor.
SENSOR_SN	The serial number of sensor.

Parameter	Description
SENSOR_CAL_METHOD	The method of last sensor calibration. ISO defines several standard methods of calibration. This parameter is intended to record that method, or if some other method was used.
SENSOR_CAL_LOC	The location of last sensor calibration. This describes the physical location at which the calibration was performed.
SENSOR_CAL_DATE	The date of the last sensor calibration.
SENSOR_CAL_WHO	The name of person who is in charge of last calibration.
SENSOR_ISOLATION_MTL	Defines the construction material of the isolating diaphragms.
SENSOR_FLUID	Defines the type of fill fluid used in the sensor
SECONDARY_VALUE	The secondary value (temperature value), related to the sensor.
SECONDARY_VALUE_UNIT	The engineering units to be used with SECONDARY_VALUE.
PRESS_LIN_NORMAL	The Linear Normalized Pressure value.
PRESS_NORMAL	The Normalized Pressure value.
PRESS_CUTOFF	The Cutoff Pressure value.
CUTOFF_FLAG	The bypass flag for Pressure value.
DIGITAL_TEMPERATURE	The digital temperature value.
DIFF	The differential pressure value.
YDIFF	The y differential pressure value.
CAPACITANCE_LOW	The low capacitance value.
CAPACITANCE_HIGH	The high capacitance value.
BACKUP_RESTORE	This parameter is used to do backup or to restore configuration data.
SENSOR_RANGE_CODE	Indicates the sensor range code.
COEFF_POL0	The polynomial coefficient 0.
COEFF_POL1	The polynomial coefficient 1.
COEFF_POL2	The polynomial coefficient 2.
COEFF_POL3	The polynomial coefficient 3.
COEFF_POL4	The polynomial coefficient 4.
COEFF_POL5	The polynomial coefficient 5.
COEFF_POL6	The polynomial coefficient 6.
COEFF_POL7	The polynomial coefficient 7.
COEFF_POL8	The polynomial coefficient 8.
COEFF_POL9	The polynomial coefficient 9.
COEFF_POL10	The polynomial coefficient 10.
COEFF_POL11	The polynomial coefficient 11.
POLYNOMIAL_VERSION	Indicates the polynomial version.
CHARACTERIZATION_TYPE	Indicates the type of characterization curve.
CURVE_BYPASS_LD	Enable and disable the characterization curve.
CURVE_LENGTH	Indicates the length of characterization curve.
CURVE_X	Input points of characterization curve.
CURVE_Y	Output points of characterization curve.
CAL_POINT_HI_BACKUP	Indicates the backup for high calibration point.
CAL_POINT_LO_BACKUP	Indicates the backup for low calibration point.
CAL_POINT_HI_FACTORY	Indicates the factory high calibration point.
CAL_POINT_LO_FACTORY	Indicates the factory low calibration point.
CAL_TEMPERATURE	Defines the temperature calibration point.
DATASHEET	Indicates information about the sensor.
ORDERING_CODE	Indicates information about the sensor and control from factory production.
MAXIMUM_MEASURED_PRESSURE	Indicates the maximum pressure measured
MAXIMUM_MEASURED_TEMPERATURE	Indicates the maximum temperature measured
ACTUAL_OFFSET	Indicates the actual calibrated offset
ACTUAL_SPAN	Indicates the actual span offset

Parameter	Description
MAXIMUM_OFFSET_DEVIATION	Defines the maximum offset before an alarm is generate
MAXIMUM_GAIN_DEVIATION	Defines the maximum gain before an alarm is generate
OVERPRESSURE_LIMIT	Defines the maximum overpressure limit before an alarm is generate
MAXIMUM_NUMBER_OF_OVERPRESSURE	Defines the maximum number of overpressure before an alarm is generate

Table 3.1 – Pressure Transmitter Block Parameter Description

Pressure Transmitter Block Parameter Attributes

Rel. Index	Parameter	Obj. Type	Data Type	Storage	Size	Valid Range	Initial/Default Value	Units	Class	View
1	ST_REV	S	Unsigned16	S	2	Positive	0	none	R/W	1, 2, 3, 4
2	TAG_DESC	S	VisibleString	S	32		Null	na	R/W	
3	STRATEGY	S	Unsigned16	S	2		0	none	R/W	4
4	ALERT_KEY	S	Unsigned8	S	1	1-255	0	na	R/W	4
5	MODE_BLK	R	DS-69	S	4	OOS,AUTO	OOS	none	R/W	1
6	BLOCK_ERR	S	Bit String	D	2		Out of Service	E	R	1
7	UPDATE_EVT	R	DS-73	D	5		*	na	R	
8	BLOCK_ALM	R	DS-72	D	13		*	na	R	
9	TRANSDUCER_DIRECTORY	S	Array of Unsigned16	N	Variable		0	none	R	
10	TRANSDUCER_TYPE	S	Unsigned16	N	2		Pressure	none	R	1, 2, 3, 4
11	XD_ERROR	S	Unsigned8	D	1		Default value set	none	R	
12	COLLECTION_DIRECTORY	S	Array of Unsigned 32	S	Variable		0	None	R	3
13	PRIMARY_VALUE_TYPE	S	Unsigned16	S	2		Diff Pressure	None	R	2, 3
14	PRIMARY_VALUE	R	DS-65	D	5		*	XD_SCALE	R	1
15	PRIMARY_VALUE_RANGE	R	DS-68	S	11		*	XD_SCALE	R	4
16	CAL_POINT_HI	S	Float	S	4		*	CAL_UNIT	R/W	2, 3
17	CAL_POINT_LO	S	Float	S	4		*	CAL_UNIT	R/W	2, 3
18	CAL_MIN_SPAN	S	Float	S	4	URL/40 to URL	*	CAL_UNIT	R	3, 4
19	CAL_UNIT	S	Unsigned16	S	2		*	E	R	3, 4
20	SENSOR_TYPE	S	Unsigned16	S	1		Capacitance	na	R/W	3, 4
21	SENSOR_RANGE	R	DS-68	S	11		*	XD_SCALE	R	4
22	SENSOR_SN	S	Unsigned32	S	4	0 to 2 ³²	*	None	R/W	4
23	SENSOR_CAL_METHOD	S	Unsigned8	S	1		Factory Cal.	none	R/W	4
24	SENSOR_CAL_LOC	S	VisibleString	S	32		NULL	none	R/W	
25	SENSOR_CAL_DATE	S	Time of Day	S	7		Unspecified	none	R/W	
26	SENSOR_CAL_WHO	S	VisibleString	S	32		NULL	none	R/W	
27	SENSOR_ISOLATION_MTL	S	Unsigned16	S	2		Unspecified	none	R/W	4
28	SENSOR_FLUID	S	Unsigned16	S	2		Inert	none	R/W	4
29	SECONDARY_VALUE	R	DS-65	D	5		*	SVU	R	1
30	SECONDARY_VALUE_UNIT	S	Unsigned16	S	2		Celsius	E	R	2
31	PRESS_LIN_NORMAL	R	DS-65	D	5	± 1	*	none	R	
32	PRESS_NORMAL	R	DS-65	D	5	± 1	*	none	R	
33	PRESS_CUTOFF	R	DS-65	D	5	± 1	*	none	R	
34	PRESS_CUTOFF	S	Unsigned8	S	1	True/False	False	none	R/W	
35	DIGITAL_TEMPERATURE	R	DS-65	D	5	0-255	*	none	R	
36	DIFF	S	Float	D	4		*	none	R	
37	YDIFF	S	Float	D	4		*	none	R	
38	CAPACITANCE_LOW	S	Float	D	4		*	none	R	
39	CAPACITANCE_HIGH	S	Float	D	4		*	none	R	

Rel. Index	Parameter	Obj. Type	Data Type	Storage	Size	Valid Range	Initial/Default Value	Units	Class	View
40	BACKUP_RESTORE	S	Unsigned8	S	1		None	none	R/W	4
41	SENSOR_RANGE_CODE	S	Unsigned16	S	2		*	none	R/W	4
42	COEFF_POL0	S	Float	S	4	± INF	*	none	R/W	4
43	COEFF_POL1	S	Float	S	4	± INF	*	none	R/W	4
44	COEFF_POL2	S	Float	S	4	± INF	*	none	R/W	4
45	COEFF_POL3	S	Float	S	4	± INF	*	none	R/W	4
46	COEFF_POL4	S	Float	S	4	± INF	*	none	R/W	4
47	COEFF_POL5	S	Float	S	4	± INF	*	none	R/W	4
48	COEFF_POL6	S	Float	S	4	± INF	*	none	R/W	4
49	COEFF_POL7	S	Float	S	4	± INF	*	none	R/W	4
50	COEFF_POL8	S	Float	S	4	± INF	*	none	R/W	4
51	COEFF_POL9	S	Float	S	4	± INF	*	none	R/W	4
52	COEFF_POL10	S	Float	S	4	± INF	*	none	R/W	4
53	COEFF_POL11	S	Float	S	4	± INF	*	none	R/W	4
54	POLYNOMIAL_VERSION	S	Unsigned8	S	1	30h to FFh	*	None	R/W	4
55	CHARACTERIZATION_TYPE	S	Unsigned8	S	1		Other	None		2
56	CURVE_BYPASS_LD	S	Unsigned16	S	2		Disable or allow enter points	None	R/W	2, 3
57	CURVE_LENGTH	S	Unsigned8	S	1	2 to 5	5	None	R/W	2
58	CURVE_X	R	Array of Float	S	20		*	None	R/W	2
59	CURVE_Y	R	Array of Float	S	20		*	None	R/W	2
60	CAL_POINT_HI_BAKUP	S	Float	S	4		*	CAL_UNIT	R	2
61	CAL_POINT_LO_BAKUP	S	Float	S	4		*	CAL_UNIT	R	2
62	CAL_POINT_HI_FACTORY	S	Float	S	4		*	CAL_UNIT	R	
63	CAL_POINT_LO_FACTORY	S	Float	S	4		*	CAL_UNIT	R	
64	CAL_TEMPERATURE	S	Float	S	4	-40 a 85 °C	*	°C	R/W	
65	DATASHEET	R	Array of Unsigned8	S	10		*	None	R/W	
66	ORDERING_CODE	S	VisibleString	S	50		Null	None	R/W	
67	MAXIMUM_MEASURED_PRESSURE	S	Float	S	4	± INF	- Inf	none	R/w	
68	MAXIMUM_MEASURED_TEMPERATURE	S	Float	S	4	± INF	- Inf	none	R/W	
69	ACTUAL_OFFSET	S	Float	S	4	± INF	*	none	R	
70	ACTUAL_SPAN	S	Float	S	4	± INF	*	none	R	
71	MAXIMUM_OFFSET_DEVIATION	S	Float	S	4	± INF	0.5	none	R/W	
72	MAXIMUM_GAIN_DEVIATION	S	Float	S	4	± INF	2.0	none	R/W	
73	OVERPRESSURE_LIMIT	S	Float	S	4	± INF	+ Inf	none	R/W	
74	MAXIMUM_NUMBER_OF_OVERPRESSURE	S	Float	S	4	± INF	0	none	R/W	

Table 3.2 – Pressure Transmitter Blocks Parameter Attributes

How to Configure a Transducer Block

Each time a field device is selected on the SYSCON by instantiating them on the Operation menu, automatically a transducer block appears on the screen.

The icon indicates that a transducer block has been created, and by clicking twice on the icon, it can be accessed.

The transducer block has an algorithm, a set of contained parameters and a channel connecting it to a function block.

The algorithm describes the behavior of the transducer as a data transfer function between the I/O hardware and other function blocks. The set of contained parameters are unable to link to other blocks. These contained parameters define the user interface to the transducer block. They can be divided into Standard and Manufacturer Specific.

The standard parameters will be present for pressure, temperature, actuation devices, etc., regardless of the manufacturer. Oppositely, the manufacturers' specific ones are defined by themselves for their own purposes. As common manufacturer specific parameters, there are calibration settings, material information, linearization curve, etc.

When a standard routine calibration is performed, the user conducts a step by step method. The method is generally defined as a guideline to help the user with common tasks. The SYSCON identifies each method associated with the parameters and enables the interface to it.

The SYSCON configuration software can configure many parameters of the Input Transducer block.



The device was instantiated as LD302

Here, you can see all blocks instantiated.

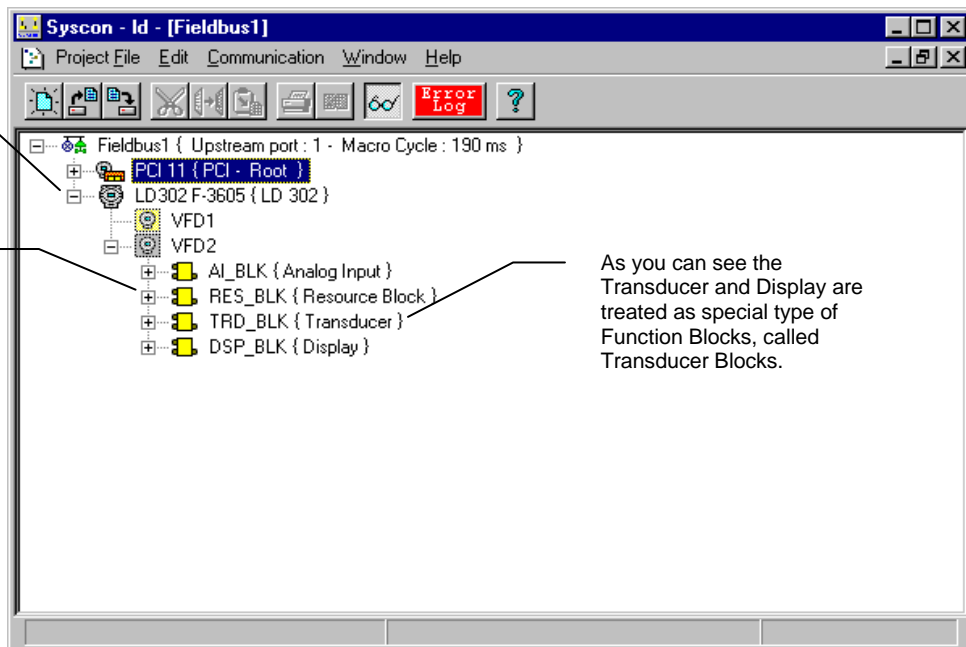

As you can see the Transducer and Display are treated as special type of Function Blocks, called Transducer Blocks.

Figure 3.1 - Function and Transducer Blocks

Lower and Upper Trim

Each sensor has a characteristic curve that relates the applied pressure and the sensor signal. This curve is determined for each sensor and it is stored in a memory along with the sensor. When the sensor is connected to the transmitter circuit, the content of its memory is made available to the microprocessor.

Sometimes the value on the transmitter display and the transducer block reading may not match to the applied pressure. The reasons may be:

- The transmitter mounting position.
- The user's pressure standard differs from the factory standard.
- The transmitter had its original characterization curve shifted by overpressure, over heating or by long term drift.

The TRIM is used to match the reading with the applied pressure. There are two types of trim available:

Lower Trim: It is used to trim the reading at the lower range. The operator informs the **LD302** of the correct reading for the applied pressure. The most common discrepancy is the lower reading.

NOTE

Check on section 1, the note on the influence of the mounting position on the indicator. For better accuracy, the trim adjustment should be made in the in the lower and upper values of the operation range values.

Upper Trim: It is used to trim the reading at the upper range. The operator informs the correct reading for the applied pressure.

For accuracy, trim should be done within the operating range. The Figures 3.2, 3.3 and 3.4 shows the trim adjustment operation into SYSCON.

Pressure Trim - LD302



Via SYSCON

It is possible to calibrate the transmitter through the parameters CAL_POINT_LO and CAL_POINT_HI.

A convenient engineering unit should be chosen before starting the calibration. This engineering unit is configured by the CAL_UNIT parameter. After its configuration the parameters related to calibration will be converted to this unit.

The parameter CAL_UNIT should be configured according to the desired Engineering Unit in the device calibration process

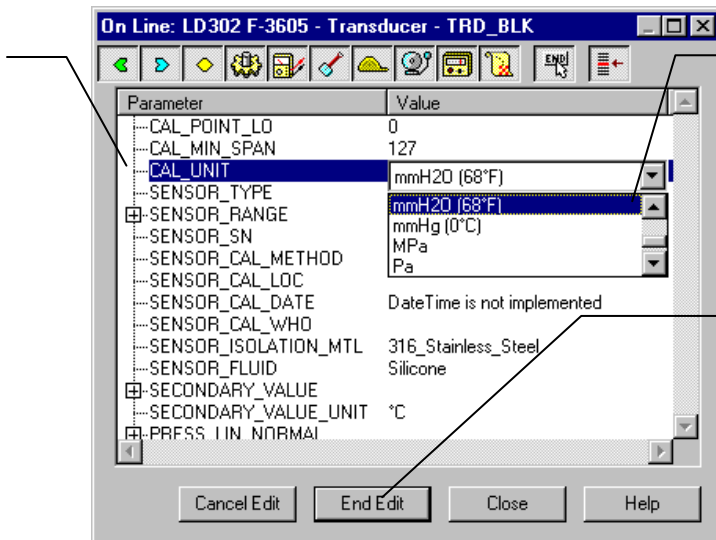

The Engineering Units can be chosen from the Pressure Units list box.

After the selection this key should be pressed to complete the operation

Figure 3.2 - LD302 SYSCON - Transducer Configuration Screen

The following engineering unit's codes are defined for pressure according to Fieldbus Foundation ® standard:

UNIT	CODES
InH ₂ O to 68°F	1148
InHg to 0°C	1156
ftH ₂ O to 68°F	1154
mmH ₂ O to 68°F	1151
mmHg to 0°C	1158
Psi	1141
Bar	1137
mbar	1138
g/cm ²	1144
kg/cm ²	1145
Pa	1130
KPa	1133
Torr	1139
Atm	1140
MPa	1132
inH ₂ O to 4°C	1147
mmH ₂ O to 4°C	1150

Table 3.3 - Engineering Units for Pressure



CAL_UNIT allows the user to select different units for calibration purposes than the units defined by SENSOR_RANGE. The SENSOR_RANGE parameter defines the maximum and minimum values the sensor is capable of indicating, the engineering units used, and the decimal point.

Let's take the lower value as an example:

Apply the input zero or the lower pressure value in an engineering unit, (the same used in parameter CAL_UNIT), and wait for the readout of the parameter PRIMARY_VALUE to stabilize.

Write zero or the lower value in the parameter CAL_POINT_LO. For each value written a calibration is performed at the desired point.

The Lower Range Value should be entered. This value must be within of the Sensor range limits allowed for each type of sensor.

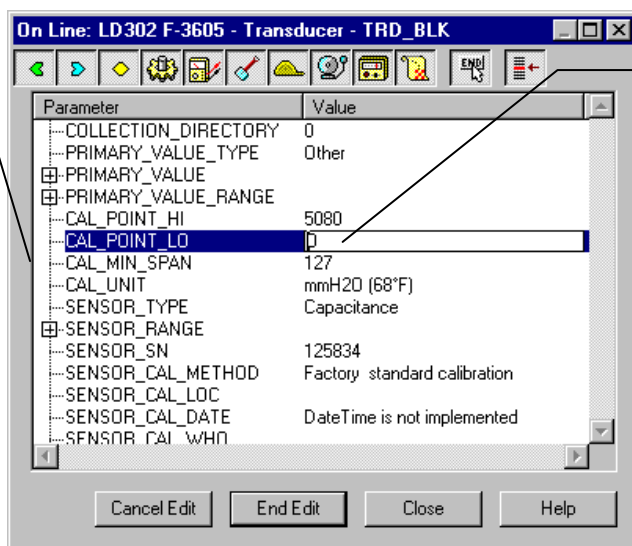

In this case, a range 2 sensor is used: The URL is 0 mmH2O or 0 inH2O.

Figure 3.3 - LD302 SYSCON - Transducer Configuration Screen



Let's take the upper value as an example:

Apply the input to the upper value of 5,000mmH2O of pressure and wait for the readout of the parameter PRIMARY_VALUE to stabilize. Then, write the upper value, (5,000mmH2O) in the parameter CAL_POINT_HI. For each value written a calibration is performed at the desired point.

The Upper Range Value should be entered. This value must be within of the Sensor range limits allowed for each type of sensor.

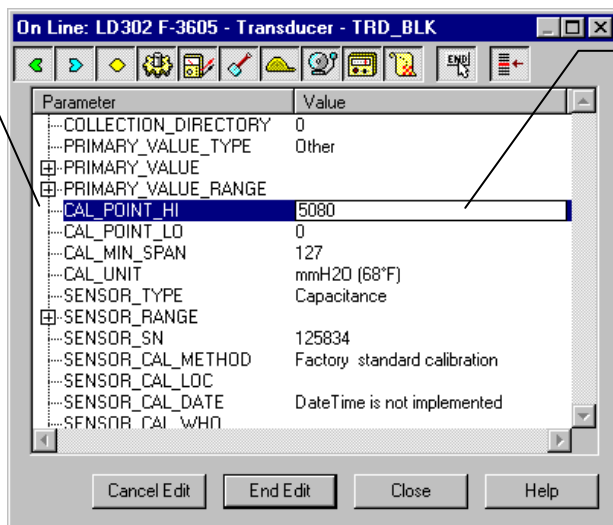

In this case, a range 2 sensor is used: The URL is 5080 mmH2O or 200 inH2O.

Figure 3.4 - LD302 SYSCON - Transducer Configuration Screen

WARNING

It is recommended that a convenient engineering unit be chosen through the XD_SCALE parameter of the Analog Input Block, considering that the range limits of the sensor must be respected. (100% and 0%).

It is also recommended for every new calibration, to save existing trim data in parameters CAL_POINT_LO_BACKUP and CAL_POINT_HI_BACKUP, by means of parameter BACKUP_RESTORE, using option LAST_TRIM_BACKUP.

Through Local Adjustment

In order to enter the local adjustment mode, place the magnetic tool in the orifice “Z” until flag “MD” lights up on the display. Remove the magnetic tool from “Z” and place it in orifice “S”. Remove and reinsert the magnetic tool in “S” until the message “LOC ADJ” is displayed. The message will be displayed for approximately 5 seconds after the user removes the magnetic tool from “S”. The upper value is taken as an example:

Apply to the input a pressure of 5,000 mmH₂O.

Wait for the pressure readout of the parameter P_VAL (PRIMARY_VALUE) to stabilize and then set the UPPER parameter until it reads 5,000.

NOTE

The exit of the trim mode on the local adjustment occurs automatically when the magnetic tool is not used for 15 seconds

Even when parameters LOWER or UPPER already present the desired value, they must be actuated so that calibration is performed.

Limit Conditions for Calibration:

For every writing operation in the transducer blocks there is an indication for the operation associated with the waiting method. These codes appear in parameter XD_ERROR. Every time a calibration is performed. Code 0, for example, indicates a successfully performed operation.

Upper:

$SENSOR_RANGE_EU0 < NEW_UPPER < SENSOR_RANGE_EU100 * 1.25$

Otherwise, XD_ERROR = 26.

$(NEW_UPPER - PRIMARY_VALUE) < SENSOR_RANGE_EU100 * 0.1$

Otherwise, XD_ERROR = 27.

$(NEW_UPPER - CAL_POINT_LO) > CAL_MIN_SPAN * 0,75$

Otherwise, XD_ERROR = 26.

NOTE

Codes for XD_ERROR:

16: Default Value Set

22: Out of Range.

26: Invalid Calibration Request.

27: Excessive Correction.

Characterization Trim

It is used to correct the sensor reading in several points.

Use an accurate and stable pressure source, preferably a dead-weight tester. To guarantee the accuracy, the tester should be at least three times more accurate than the transmitter. Wait for the pressure to stabilize before performing the trim.

The sensor characteristic curve at a certain temperature and for certain ranges may be slightly nonlinear. This eventual non-linearity may be corrected through the Characterization Trim.

The user may characterize the transmitter throughout the operating range, obtaining even better accuracy.

The characterization is determined from two to five points. Just apply the pressure and inform the transmitter the pressure that is being applied.

WARNING

The characterization trim changes the transmitter characteristics.
 Read the instructions carefully and verify that a pressure standard with accuracy of 0.03% or better is being used; otherwise the transmitter accuracy will be seriously affected.

Characterize a minimum of two points. These points will define the characterization curve. The maximum number of points is five. It is recommended to select the points equally distributed over the desired range or over a part of the range where more accuracy is required.

The Figure 3.5 shows the SYSCON window to characterize a new curve. Note that CURVE_Y indicates the applied pressure according to the standard pressure source. CURVE_X indicates measured pressure value to **LD302**.

The number of points is configured in the parameter CURVE_LENGTH, being in the maximum of 5 points. The entry points will be configured in the CURVE_X and of output in the CURVE_Y.

The Parameter CURVE_BYPASS_LD controls the enabling/disabling of the curve and has the following options:

- "Disable",
- "Enable and Backup Cal",
- "Disable and Restore Cal",
- "Disable or Allows to enter the points"



To configure the points of the curve, the option "Disable or Allows to enter the points" must be chosen. Apply the desired pressure and wait until it stabilizes. (During stabilization, read the normalized pressure through PRESS_NORMAL parameter and with the pressure being applied, write in the parameters CURVE_X and CURVE_Y respectively). Finally it is necessary to write in the CURVE_LENGTH parameter, the number of configured points, from 2 to 5 points. In case the curve is not to be confirmed, choose the option "Disable and Restore Cal". For enabling and saving the calibration settings, choose "Enable and Backup Cal".

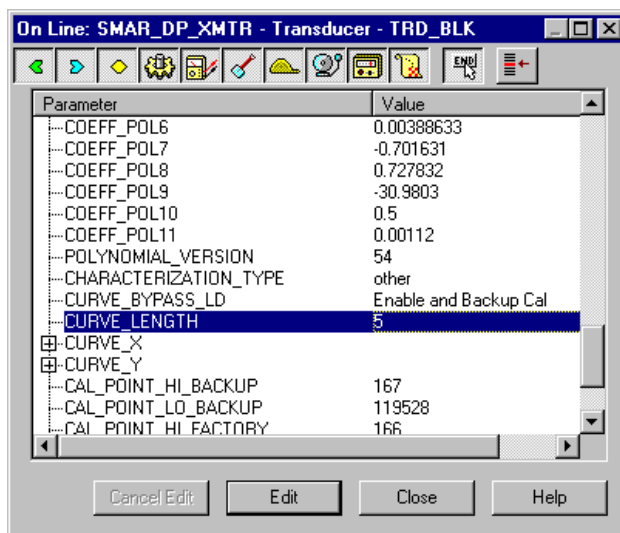
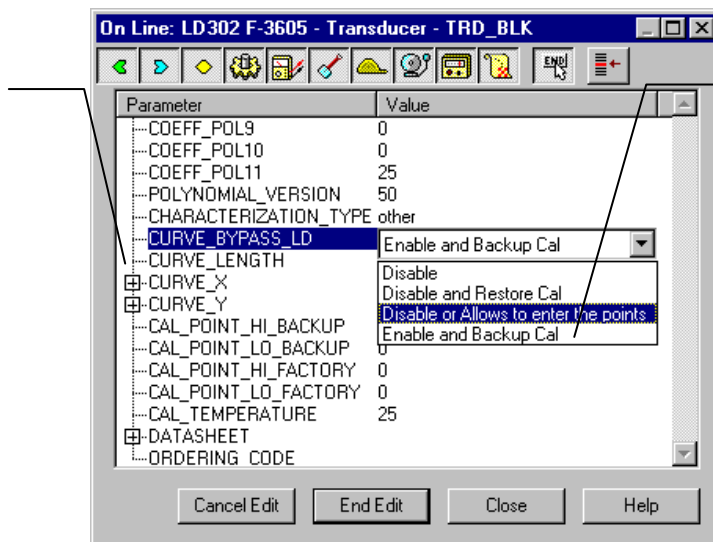

Figure 3.5 - The Characterization Curve Configuration

This parameter activates or deactivates the Characterization Curve after the points have been configured.



By the list box the user can enable or disable the Characterization Curve, enter the points, restore or backup the curve entered. This parameter should be used preferably by a calibration method.

Figure 3.6 - The Characterization Curve Configuration

Sensor Information



The main information about the transmitter can be accessed by selecting the Transducer block icon option as shown in Figure 3.10 - Creating Transducers and Function Blocks. The sensor information will be displayed as shown below.

This parameter assigns the Engineering Units for all parameters related to calibration methods. Usually, they start their names with CAL_UNIT.

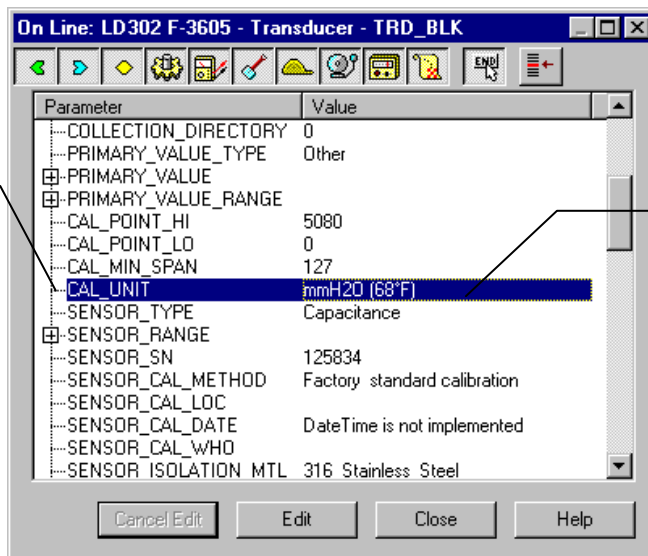

The appropriate calibration unit can be chosen by selecting the Engineering Units available for each type of Transducer Block

Figure 3.7 - Transducer Block - Sensor Information

Only application dependent options defined by combo boxes can be changed. (E.g. Flange Type, O' Ring Material, etc.) And the others are only factory configured (e.g. Sensor Isolating Diaphragm, Sensor Fluid, etc.).

Temperature Trim



Write in the TEMPERATURE_TRIM parameter any value in the range of -40°C to $+85^{\circ}\text{C}$. After that, check the calibration performance using the SECONDARY_ VALUE parameter.

By adjusting this parameter to the current temperature, the device's temperature indication is automatically adjusted.

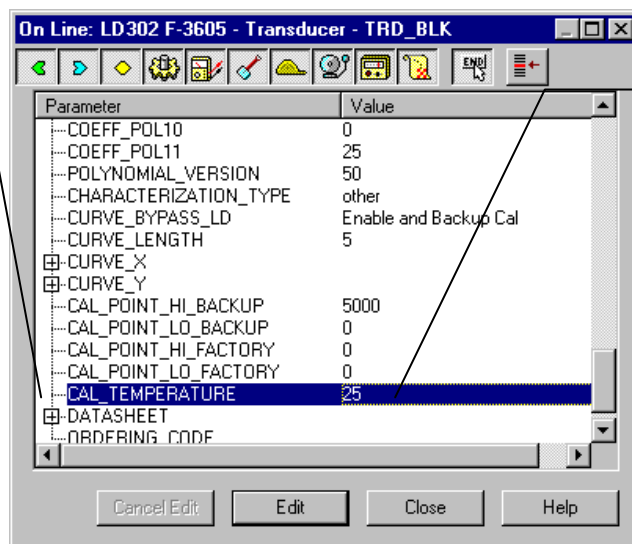

Usually, its operation is done by a method in the factory.

Figure 3.8 - The Temperature Trim Configuration

Sensor Data Reading



When the transmitter **LD302** is on, it is verified that the serial number of the sensor in the sensor board is the same as the recorded serial number in the E2PROM in the main board. When these numbers are different (a swap of sensor set or main board was carried through) the data stored in the E2PROM of the sensor board is copied to the E2PROM of the main board.

Through the parameter **BACKUP_RESTORE**, this reading can be made, choosing the option "SENSOR_DATA_RESTORE". The operation, in this case, is independent of the sensor serial number. Through the option "SENSOR_DATA_BACKUP", the sensor data stored in the main board EEPROM memory can be saved in the E2PROM of the sensor board. (This operation is done at factory).

Through this parameter, we can recover default data from the factory about sensor and last saved calibration settings, as well as calibrations. These are the following options:

- **Factory Cal Restore:** Recover last calibration settings made at factory;
- **Last Cal Restore:** Recover last calibration settings made by user and saved as backup;
- **Default Data Restore:** Restore all data as default;
- **Sensor Data Restore:** Restore sensor data saved in the sensor board and copy them to main board EEPROM memory.
- **Factory Cal Backup:** Copy the actual calibration settings to the factory ones;
- **Last Cal Backup:** Copy the actual calibration settings to the backup ones;
- **Sensor Data Backup:** Copy the sensor data at main board EEPROM memory to the EEPROM memory located at the sensor board;
- **None:** Default value, no action is done.

This parameter is used to save or restore the default factory or user configuration stored at the sensor module.

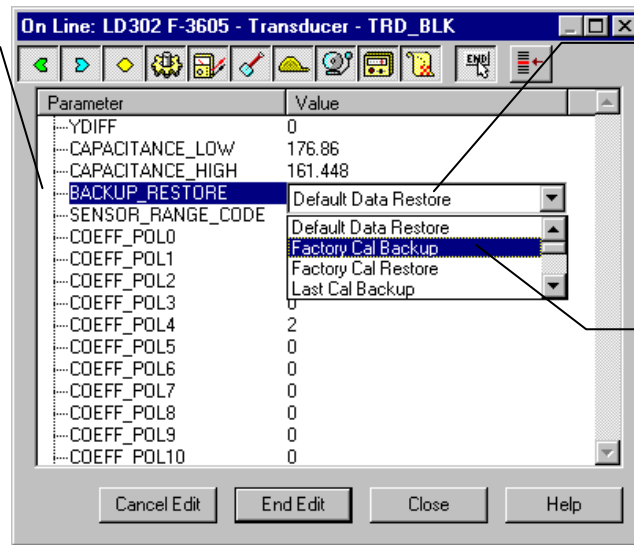

By selecting the options contained in the list box, operations of backup and restore data in the sensor module can be selected.

Using its option, the user can save the last calibration settings.

Figure 3.9 - Transducer Block - Backup/Restore

Transducer Display - Configuration

Using the SYSCON it is possible to configure the Display Transducer block. The Transducer Display is treated as a normal block by SYSCON. It means, this block has some parameters and those can be configured according to the customer's needs. See the Figure 3.10.

The customer can choose the parameters to be shown on the LCD display, they can be parameters just for monitoring purpose or for acting locally in the field devices by using a magnetic tool.

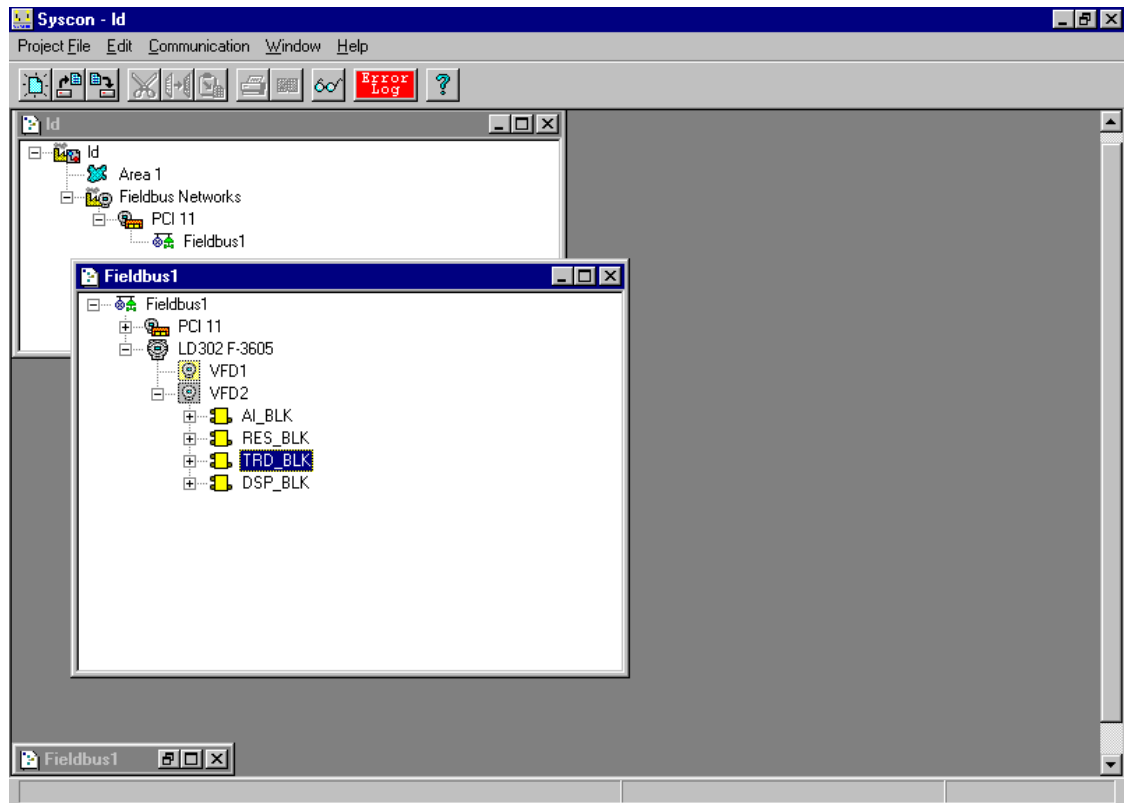

Figure 3.10 - Creating Transducers and Function Blocks

Display Transducer Block

The local adjustment is completely configured by SYSCON. It means, the user can select the best options to fit his application. From the factory, it is configured with the options to set the Upper and Lower trim, for monitoring the input transducer output and check the Tag. Usually, the transmitter is much better configured by SYSCON, but the local functionality of the LCD allows an easy and fast action on certain parameters, since it does not rely on communication and network wiring connections. Among the possibilities of the Local Adjustment, the following options can be brought out Mode block, Outputs monitoring, Tag visualization and Tuning Parameters setting.

The interaction between the user, is described in detail on the "General Installation, Operation and Maintenance Procedures Manual". Take a detailed look at this manual in the chapter related to "Programming Using Local Adjustment". The resources on this transducer display as well as all of the Series 302 Field Devices from Smar, have the same methodology.

Once trained, the user can handle any kind of field devices from Smar.

All function block and transducers defined according to FOUNDATION™ fieldbus have a description of their features written on binary files, by the Device Description Language.

This feature allows that third parties configurator enabled by Device Description Service technology can interpret these features and make them accessible to configure. The Series 302 Function Blocks and Transducers have been defined strictly according the Fieldbus Foundation specifications in order to be interoperable to other parties.

In order to enable the local adjustment using the magnetic tool, it is necessary to prepare the parameters concerning this operation via SYSCON (System Configuration). Figures 3.8 and 3.9 shows all parameters and their respective values, which should be configured to enable local adjustment through the magnetic screwdriver according to the user's unit. All values shown on the display are default values.

There are seven groups of parameters, which may be pre-configured by the user in order to enable, a possible configuration by means of the local adjustment. As an example, suppose some parameters are not to be shown; in this case, simply write an invalid Tag in the parameter, Block_Tag_Param_X. By doing this, the device will not take the parameters related (indexed) to its Tag as valid parameters.

Definition of Parameters and Values

Idx	Parameter	Data Type (length)	Valid Range/ Options	Default Value	Units	Store	Description
7	BLOCK_TAG_PARAM	VisibleString			None	S	This is a tag of the block to which the parameter belongs to use up to a maximum of 32 characters.
8	INDEX_RELATIVE	Unsigned16	0-65535		None	S	This is the index related to the parameter to be actuated or viewed (1, 2...).
9	SUB_INDEX	Unsigned8	1-255		None	S	To visualize a certain tag, opt for the index relative equal to zero, and for the sub-index equal to one.
10	MNEMONIC	VisibleString			None	S	This is the mnemonic for the parameter identification (maximum of 16 characters). Choose the mnemonic, preferably with no more than 5 characters because, this way, it will not necessary to rotate it on display.
11	INC_DEC	Float			None	S	It is the increment and decrement in decimal units when the parameter is Float or Float Status time, or integer, when the parameter is in whole units.
12	DECIMAL_POINT_NUMBER	Unsigned8	0-4		None	S	This is the number of digits after the decimal point (0 to 3 decimal digits)
13	ACCESS	Unsigned8	Monit/Action		None	S	The access allows the user to read, in the case of the "Monitoring" option, and to write when "action" option is selected, and then the display will show the increment and decrement arrows.

Idx	Parameter	Data Type (length)	Valid Range/Options	Default Value	Units	Store	Description
14	ALPHA_NUM	Unsigned8	Mnem/Value		None	S	These parameters include two options: value and mnemonic. In option value it is possible to display data both in the alphanumeric and in the numeric fields, this way, in the case of a data higher than 10000, it will be shown in the alphanumeric field.
63	DISPLAY_REFRESH	Unsigned8	1		None	D	

In the mnemonic option, the display may show the data in the numeric field and the mnemonic in the alphanumeric field.

In case the user wants to see a certain tag, choose the index relative equal to zero, and for the sub-index equal to one (refer to paragraph Structure Block in the Function Blocks Manual).

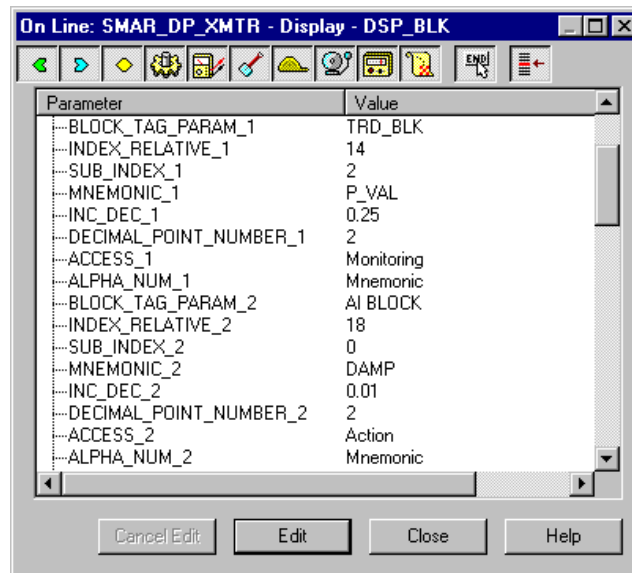

Figure 3.11 - Parameters for Local Adjustment Configuration

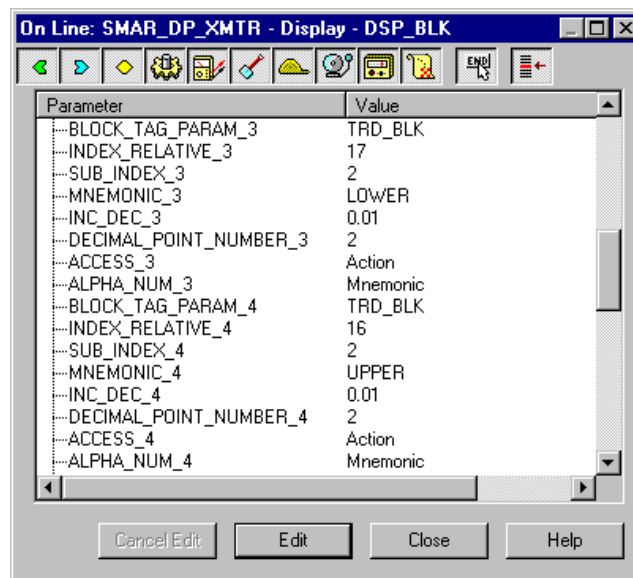

Figure 3.12 - Parameters for Local Adjustment Configuration

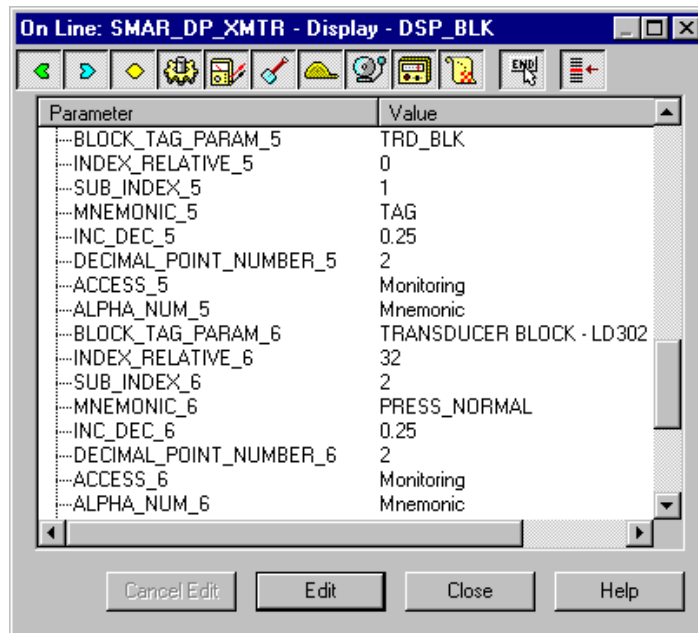

Figure 3.13 - Parameters for Local Adjustment Configuration

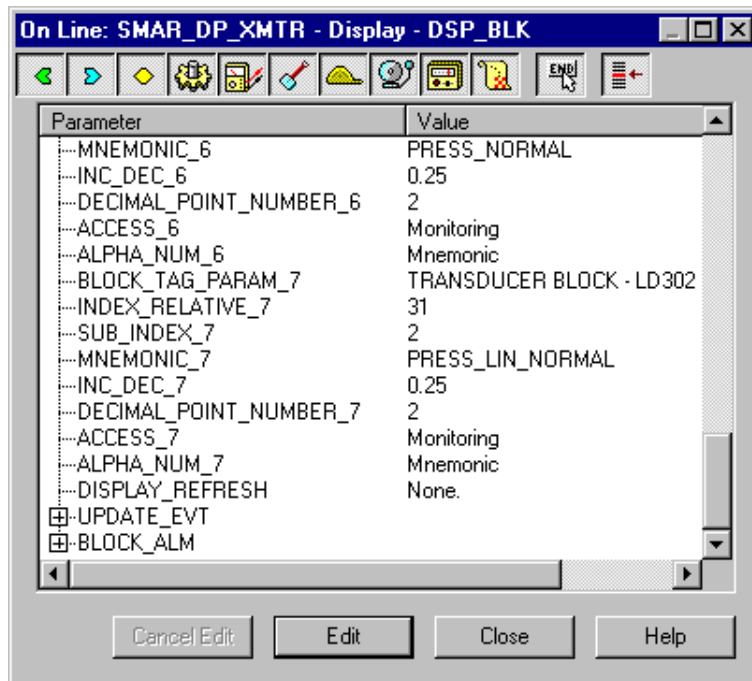

Figure 3.14 - Parameters for Local Adjustment Configuration

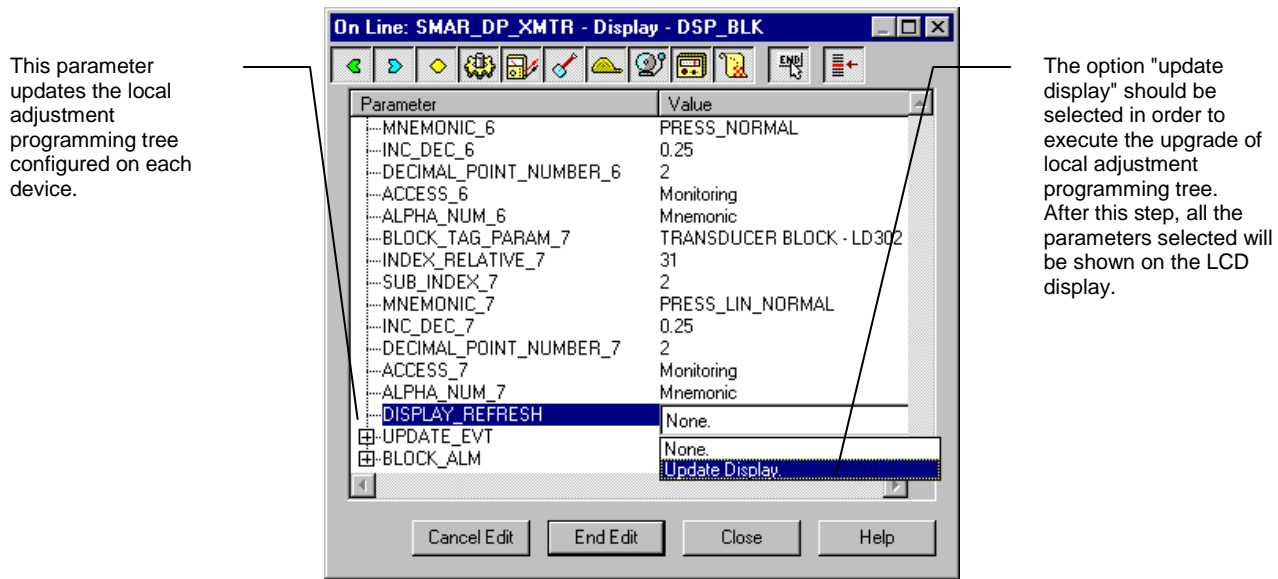

Figure 3.15 - Parameters for Local Adjustment Configuration

Programming Using Local Adjustment

The local adjustment is completely configured by SYSCON. It means, the user can select the best options for this application. From the factory, it is configured with the options to set the Upper and Lower trim, for monitoring the transducer output and check the Tag. Usually, the transmitter is much better configured by SYSCON, but the local functionality of the LCD allows an easy and fast action on certain parameters, since it does not rely on communication and network wiring connections. Among the possibilities of the Local Adjustment, the following options can be emphasized: Mode block, Outputs monitoring, Tag visualization and Tuning Parameters setting.

The interaction between the user is also described in detail on the "General Installation, Operation and Maintenance Procedures Manual". Take a look at this manual in the chapter related to "Programming Using Local Adjustment".

All function block and transducers defined according to Fieldbus Foundation™ have a description of their features written on binary files, by the Device Description Language. This feature allows that third parties configurator enabled by the Device Description Service technology can interpret these features and make them accessible to configure. The Function Blocks and Transducers of Series 302 have been defined rigorously according the Fieldbus Foundation specifications in order to be interoperable to other parties.

This magnetic tool enables adjustment of the most important parameters of the blocks.

The jumper W1 on top of the main circuit board must be in place and the positioner must be fitted with digital display for access to the local adjustment. Without the display, the local adjustment is not possible.

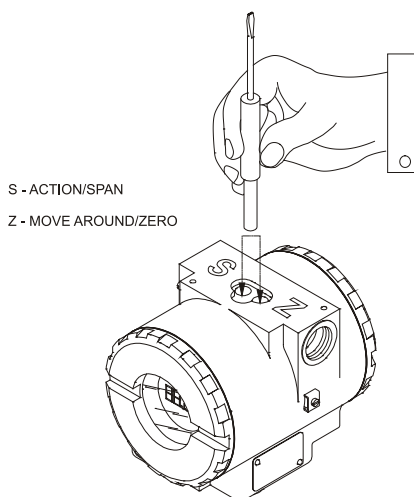

Figure 3.16 - Local Adjustment Holes

Table 3.4 shows the actions on the Z and S holes on the LD302 when Local Adjustment is enabled.

HOLE	ACTION
	Initializes and rotates through the available functions.
S	Selects the function shown in the display.

Table 3.5 - Purpose of the holes on the Housing

J1 Jumper Connections

If J1 (see figure 3.17) is connected to ON, it is possible to simulate values and status through the SIMULATE parameter, from the function blocks.

W1 Jumper Connections

If W1 is connected to ON, the local adjustment programming tree is enabled, the block parameters can be adjusted and the communication can be pre-configured via local adjustment.

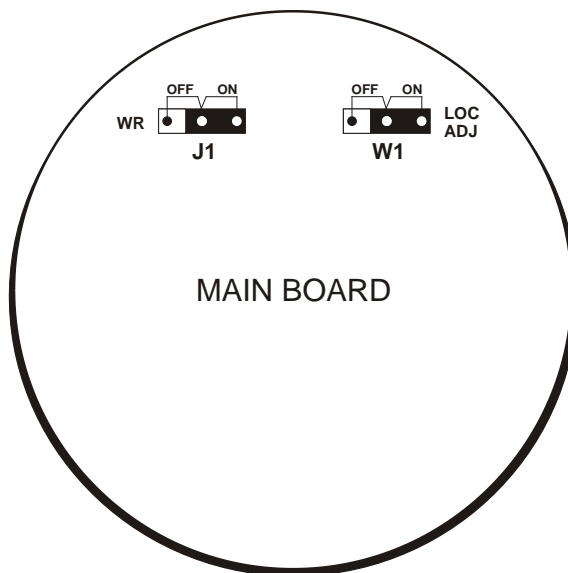

Figure 3.17 - J1 and W1 Jumpers

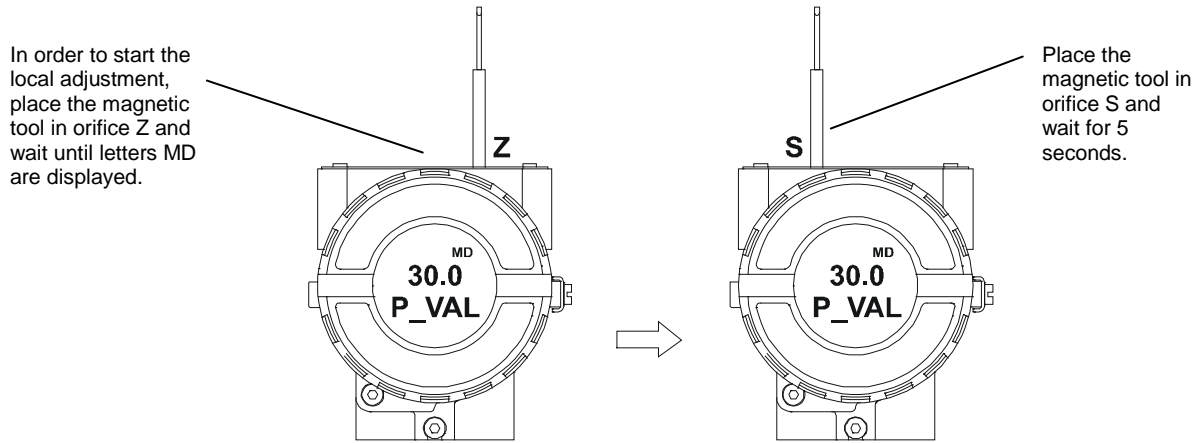

Figure 3.18 - Step 1 - LD302

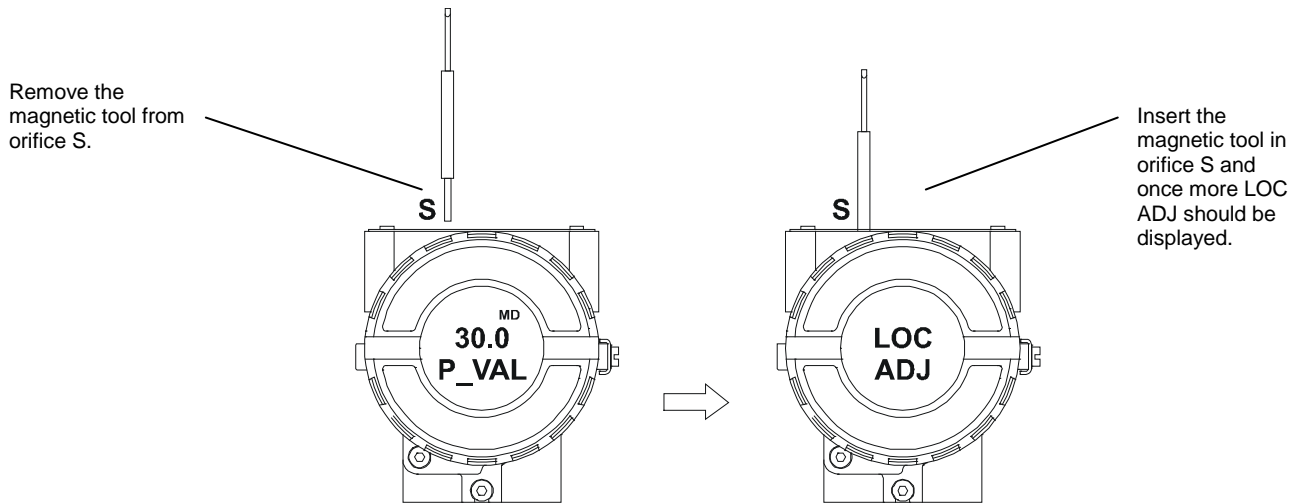

Figure 3.19 - Step 2 - LD302

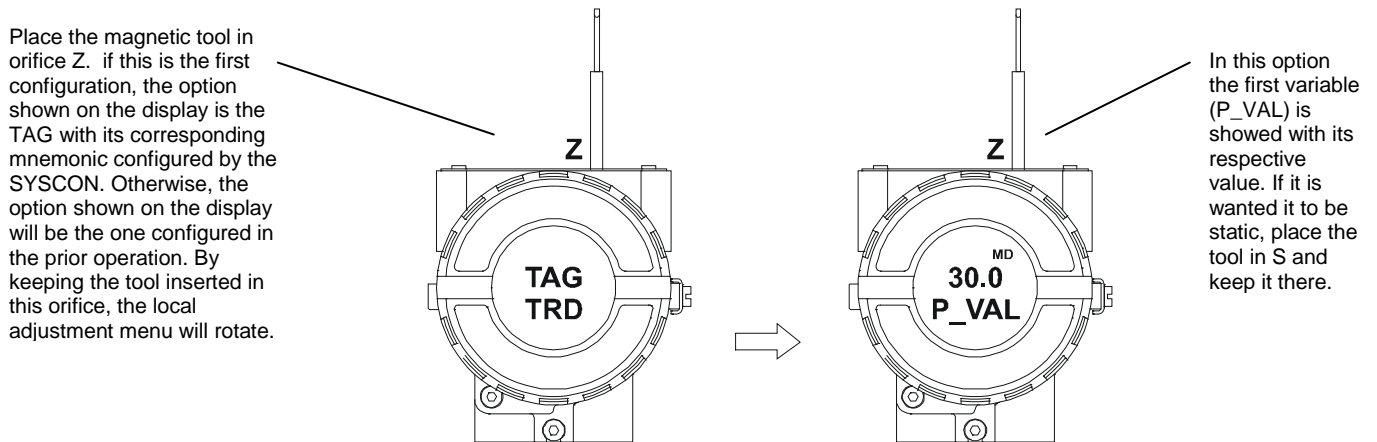
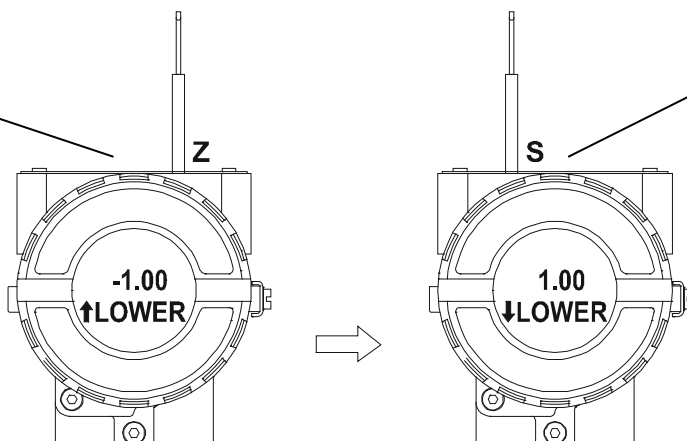

Figure 3.20 – Step 3 – LD302

In order to calibrate the lower value (LOWER), insert the magnetic tool in orifice S as soon as LOWER is shown in the display. An arrow pointing upward (↑) increments the value and an arrow pointing downward (↓) decrements the value. In order to increment the value, keep the tool inserted in S until the desired value is set.



In order to decrement the lower value, place the magnetic tool in orifice Z to shift the arrow to the downward position and then, by inserting and keeping the tool in orifice S, it is possible to decrement the lower value.

Figure 3.21 - Step 4 - LD302

In order to calibrate the upper value (UPPER), insert the magnetic tool in orifice S as soon as upper is shown in the display. An arrow pointing upward (↑) increments the value and an arrow pointing downward (↓) decrements the value. In order to increment the value, keep the tool inserted in S until the desired value is set.

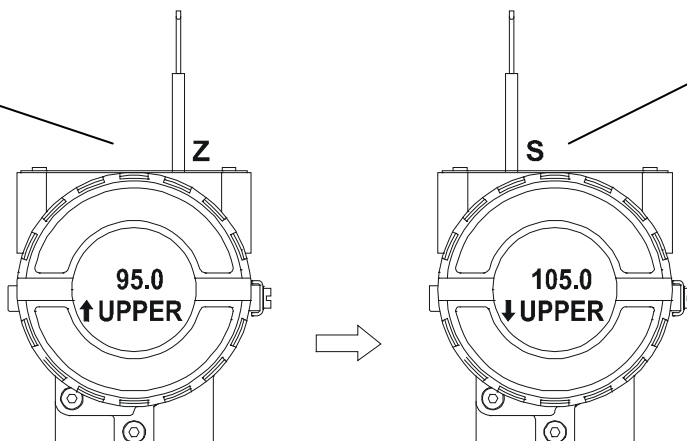

In order to decrement the upper value, place the magnetic tool in orifice Z to shift the arrow to the downward position and then, by inserting and keeping the tool in orifice S, it is possible to decrement the upper value.

Figure 3.22 - Step 5 - LD302

NOTE

This Local adjustment configuration is a suggestion only. The user may choose the best configuration via SYSCON, by just configuring the display block (See Programming Using Local Adjustment.)

Section 4

MAINTENANCE PROCEDURES

General

NOTE

Equipments installed in hazardous atmospheres must be inspected in compliance with the IEC60079-17 standard.

The **SMAR Series 302** devices are extensively tested and inspected before delivery to the end user. Nevertheless, during their design and development, consideration has been given to the possibility of repairs being made by the end user, when necessary.

In general, it is recommended that end users do not try to repair printed circuit boards. Spare circuit boards may be ordered from **SMAR** when necessary. Refer to the item "Returning Materials" at the end of this Section.

The table 4.1 will show the messages of errors and potential causes.

SYMPTOM	POSSIBLE SOURCE OF PROBLEM
NO COMMUNICATION	<p>* Transmitter Connections Check wiring polarity and continuity. Check for short circuit or ground loops. Check if the power supply connector is connected to the main board. Check if the shield is not being used as a conductor. It should be grounded at one end only.</p>
	<p>* Power Supply Check power supply output. The voltage must be between 9 - 32 VDC at the LD302 terminals. Noise and ripple should be within the following limits:</p> <p>a) 16 mV peak to peak from 7.8 to 39 KHz. b) 2 V peak to peak from 47 to 63 Hz for non-intrinsic safety applications and 0.2 V for intrinsic safety applications. c) 1.6 V peak to peak from 3.9 MHz to 125 MHz.</p>
	<p>* Network Connection Check that the topology is correct and all devices are connected in parallel. Check that two Terminators are OK and correctly positioned. Check length of trunk and spurs. Check spacing between couplers.</p>
	<p>* Electronic Circuit Failure Check the main board for defect by replacing it with a spare.</p>
	<p>* Transmitter Connections Check for intermittent short circuits, open circuits and grounding problems. Check if the sensor is correctly connected to the LD302 terminal block.</p>
INCORRECT READING	<p>* Noise, Oscillation Adjust damping Check grounding of the transmitters housing. Check that the shielding of the wires between transmitter / panel is grounded only in one end.</p>
	<p>* Sensor Check the sensor operation; it should be within its characteristics. Check sensor type; it should be configured to the LD302 affixes. Check if process is within the range of the sensor and the LD302.</p>

Table 4.1 - Error Messages and Potential Causes

If the problem is not stated in the table above, follow the Note below:

NOTE
<p>The Factory Init should be tried as a last option to recover the equipment control when the equipment presents some problem related to the function blocks or the communication. This operation must be offline and carried out only by authorized personnel, since the equipment will be configured with standard and factory data.</p> <p>This procedure resets all of the configurations running in the equipment, after which a partial download should be performed.</p> <p>Two magnetic tools should be used to this effect. On the equipment, withdraw the nut that affixes the identification tag on the top of the housing, so that access is gained to the "S" and "Z" holes.</p> <p>The operations to follow are:</p> <ol style="list-style-type: none">1) Switch off the equipment, insert the magnetic tools and keep them in the holes (the magnetic end in the holes);2) Supply the equipment;3) As soon as the Factory Init is shown on the display, take off the tools and wait for the "5" symbol on the right upper corner of the display to disappear, thus indicating the end of the operation. <p>This procedure makes effective the entire factory configuration and will eliminate eventual problems with the function blocks or with the equipment communication.</p>

Disassembly Procedure

WARNING
Do not disassemble with power on.

The Figure 4.4 shows an exploded view of the transmitter and will help to visualize the following.

Sensor Cleaning

In order to have access to the sensor **(19)** for cleaning purposes, the transmitter should be removed from its process connections. The transmitter should be isolated from the process by means of manifolds or valves; then, the drain **(13)** must be opened to exhaust any remaining pressure.



Figure 4.1 - Sensor Safety Rotation

After this, the transmitter may be removed from the standpipe. The flange bolts **(16)** may now be loosened crosswise, one at a time. After removing bolts and flanges **(15)**, the isolating diaphragms will be easily accessible for cleaning.

Cleaning should be done carefully in order to avoid damaging the delicate isolating diaphragms. The use of a soft cloth and a non-acid solution is recommended.

The oscillating circuit is a part of the sensor and the replacement of one implies replacing the other.

To remove the sensor from the electronic housing, the electrical connections (in the field terminal side) and the main board connector must be disconnected.

Loosen the hex screw (20) and carefully unscrew the electronic housing from the sensor, observing that the flat cable is not excessively twisted.

WARNING

To avoid damage do not rotate the electronic housing more than 270° starting from the fully threaded without disconnecting the electronic circuit from the sensor and from the power supply. See Figure 4.1.

Electronic Circuit

To remove the circuit board (5), loosen the two screws (3) that anchor the board.

WARNING

The board has CMOS components, which may be damaged by electrostatic discharges. Observe correct procedures for handling CMOS components. It is also recommended to store the circuit boards in electrostatic-proof cases.

Pull the main board out of the housing and disconnect the power supply and the sensor connectors.

Reassembly Procedure

WARNING

Do not assemble the main board with power on.

Sensor Mounting

When mounting the sensor (19), it is recommended to make use of a new set of gaskets (18 & 24) compatible with the process fluid. The bolts, nuts, flanges and other parts should be inspected for corrosion or other eventual damage. Damaged parts should be replaced.

NOTE

Backup Rings

High pressure transmitters **A5, A6, M5, M6** and High static pressure transmitters **H2, H3, H4, H5** and the sensors with tantalum diaphragm that use Buna-N or Viton O_Ring, must use a metallic backup Ring (17) to prevent extrusion of O_Ring. Do not use the backup O-Ring when the flange has an insert of **Kynar** (PVDF).

Avoid bending the backup ring and inspect it for knots, cuts etc. Be careful when mounting it. The flat side, which shines more than the beveled side should be mounted against the O_Ring. **(See Figure 4.2 – Backup Ring Mounting).**

For these models, when teflon O-ring is used, it must be a special "SPRING LOADED" O_ring. See the spare parts list for the appropriate part number.

Gaskets should be lightly lubricated with silicone oil before they are fitted into their recesses. Use halogen grease for inert fill applications. The flanges should then be positioned in order to press them in place. With the flanges holding the O-Rings in place, insert the four bolts (16) and tighten the nuts (23) finger tight, making sure the flanges remain parallel all the time.

Tighten one nut until the flange seats.

Tighten the nut diagonally across with a torque of approximately 2.75 ±0.25 kgf.m.

Tighten the first nut with the same torque.

Verify the flange alignment.

Check torque on the four bolts.

If adapters (25) have been removed, it is recommended to replace gaskets (24) and to connect the adapters to the process flanges before coupling them to the sensor. Optimum torque is 2.75 ±0.25 Kgf.m.

The fitting of the sensor must be done with the main board out of the electronic housing. Mount the sensor to the housing turning clockwise until it stops. Then turn it counterclockwise until it faces the protective cover (1) parallel to the process flange. Tighten the hex screw (20) to lock the housing to the sensor.

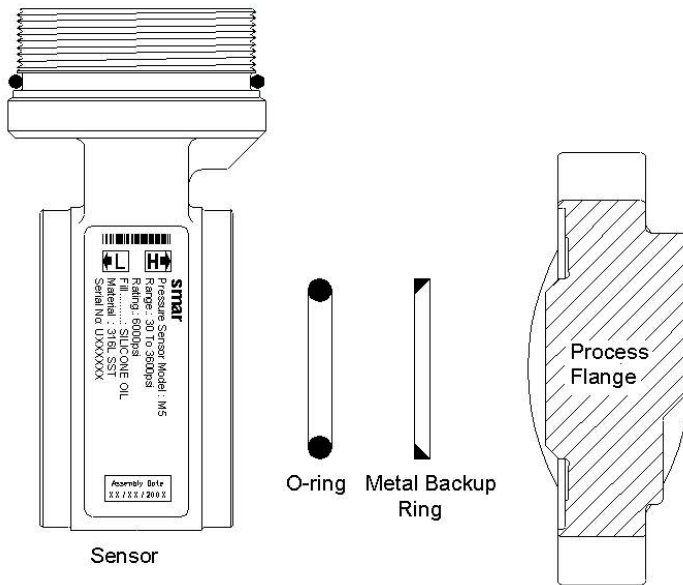

Figure 4.1 - Backup Ring Mounting

Electronic Circuit

Plug sensor connector and power supply connector to main board.

Attach the display to the main board. Observe the four possible mounting positions. The SMAR mark indicates the up position.

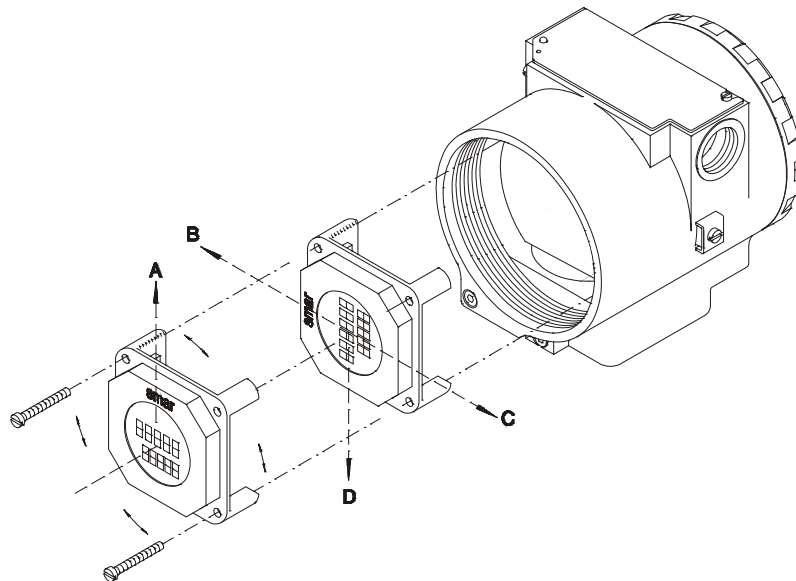

Figure 4.2 - Four Possible Positions of the Display

Anchor the main board and display with their screws (3).

After tightening the protective cover (1), mounting procedure is complete. The transmitter is ready to be powered and tested. It is recommended to open the transmitter's pressure taps to atmosphere and adjust the TRIM.

Interchangeability

In order to obtain an accurate and better temperature compensated response, each sensor is submitted to a characterization process and the specific data is stored in an EEPROM located in the sensor body.

Each time the power is turned on, the main circuit reads the sensor serial number. If it is different from the number stored in the memory, the circuit recognizes that there is a new sensor and the following information is transferred from the sensor to the main circuit;

Temperature compensation coefficients.

Sensor's trim, including 5-point characterization curve.

Sensor characteristics: type, range, diaphragm material and fill fluid.

The other transmitter characteristics are stored in the main circuit memory and are not affected by sensor change.

Upgrading LD301 to LD302

The sensor and housing of the LD301 is exactly the same as the **LD302**. By changing the circuit board of the LD301 it becomes a **LD302**. The display on the LD301 version 5.XX is the same as on **LD302** and can therefore be used with the **LD302** upgrade circuit board. With an LD301 version three or earlier, that display cannot be used.

Upgrading the LD301 to a **LD302** is therefore very much the same as the procedure for replacing the main board described above.

To remove the circuit board (5), loosen the two screws (3) that anchor the board.

Caution with the circuit boards must be as mentioned above.

Pull the LD301 main board out of the housing; disconnect the power supply and the sensor connectors.

Replace the **LD302** main board reversing the procedure for removing the LD301 circuit.

Returning Materials

Should it become necessary to return the transmitter and/or configurator to **SMAR**, simply contact our office, informing the defective instrument serial number, and return it to our factory.

If it becomes necessary to return the transmitter and/or configurator to Smar, simply contact our office, informing the defective instrument's serial number, and return it to our factory. In order to speed up analysis and solution of the problem, the defective item should be returned with the Service Request Form (SRF – Appendix B) properly filled with a description of the failure observed and with as much details as possible. Other information concerning to the instrument operation, such as service and process conditions, is also helpful.

Instruments returned or to be revised outside the guarantee term should be accompanied by a purchase order or a quote request.

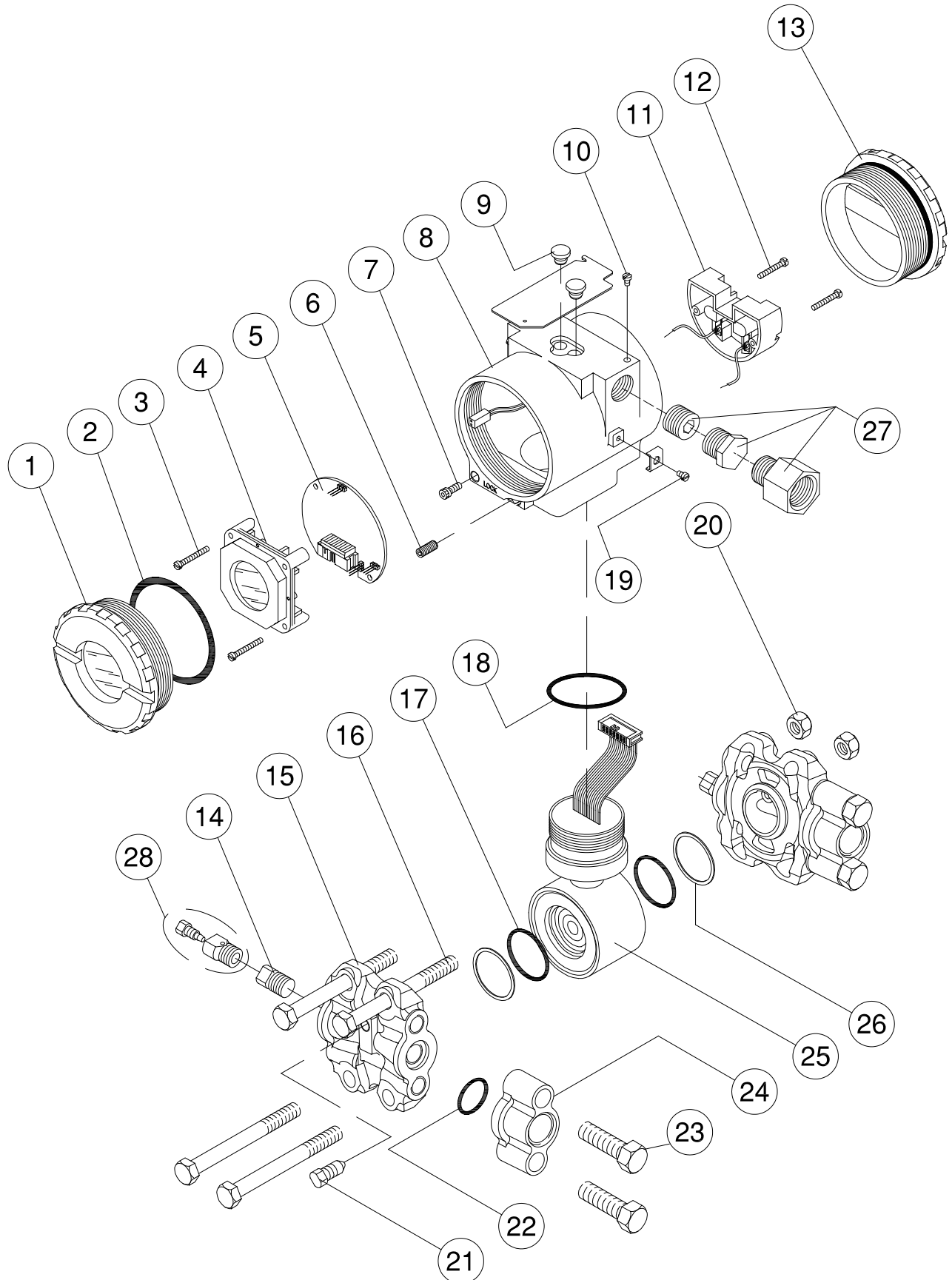

Figure 4.4 - Exploded View

ACCESSORIES	
ORDERING CODE	DESCRIPTION
SD1	Magnetic Tool for Local Adjustment
BC1	Fieldbus/RS232 Interface
SYSCON	System Configurator
PS302	Power Supply
BT302	Terminator
PCI	Process Control Interface

SPARE PARTS LIST			
DESCRIPTION OF PARTS	POSITION	CODE	CATEGORY (NOTE 1)
HOUSING, Aluminum (NOTE 2)			
½ - 14 NPT	8	304-0130	
M20 x 1.5	8	304-0131	
PG 13.5 DIN	8	304-0132	
HOUSING, 316 SS (NOTE 2)			
½ - 14 NPT	8	304-0133	
M20 x 1.5	8	304-0134	
PG 13.5 DIN	8	304-0135	
COVER (INCLUDES O'RING)			
Aluminum	1 and 13	204-0102	
316 SS	1 and 13	204-0105	
COVER WITH WINDOW FOR INDICATION (INCLUDES O'RING)			
Aluminum	1	204-0103	
316 SS	1	204-0106	
COVER LOCKING SCREW			
SENSOR LOCKING SCREW			
Without Head M6 Screw	6	400-1121	
EXTERNAL GROUND SCREW			
IDENTIFICATION PLATE FIXING SCREW			
DIGITAL INDICATOR			
TERMINAL INSULATOR			
MAIN ELECTRONIC CIRCUIT BOARD			
FLANGE (WITH HOLE FOR DRAIN/VENT)			
Plated Carbon Steel	15	204-0501	
Stainless Steel 316	15	204-0502	
Hastelloy C276	15	204-0503	
Monel 400	15	204-0504	
FLANGE (WITHOUT HOLE FOR DRAIN/VENT)			
Plated Carbon Steel	15	204-0511	
Stainless Steel 316	15	204-0512	
Hastelloy C276	15	204-0513	
Monel 400	15	204-0514	
BLANK FLANGE (FOR GAGE AND ABSOLUTE MODELS)			
Plated Carbon Steel	15	204-1101	

Stainless Steel 316	15	204-1102	
ADAPTER			
Plated Carbon Steel	24	203-0601	
Stainless Steel 316	24	203-0602	
Hastelloy C276	24	203-0603	
Monel 400	24	203-0604	
O'RINGS (NOTE 3)			
Cover, Buna-N	2	204-0122	B
Neck, Buna-N	21	204-0113	B
O'RINGS (NOTE 3)			
Flange, BUNA-N	17	203-0401	B
Flange, VITON	17	203-0402	B
Flange, TEFLON	17	203-0403	B
Flange, ETHYLENE/PROPYLENE	17	203-0404	B
Flange, TEFLON with spring LOADED (NOTE 6)	17	203-0405	B
Adapter, BUNA-N	22	203-0701	B
Adapter, VITON	22	203-0702	B
Adapter, TEFLON	22	203-0703	B
Adapter, ETHYLENE/PROPYLENE	22	203-0704	B
TERMINAL HOLDING SCREW			
Housing in Aluminum	12	304-0119	
Housing in 316 Stainless Steel	12	204-0119	
MAIN BOARD SCREW HOUSING IN ALUMINUM			
Units with indicator	3	304-0118	
Units without indicator	3	304-0117	
MAIN BOARD SCREW HOUSING IN 316 STAINLESS STEEL			
Units with indicator	3	204-0118	
Units without indicator	3	204-0117	
FLANGE BOLT			
Carbon Steel	16	203-0300	
Stainless Steel 316	16	203-0310	
FLANGE NUT			
Carbon Steel	20	203-0302	
Stainless Steel 316	20	203-0312	
ADAPTER BOLT			
Carbon Steel	23	203-0350	
Stainless Steel 316	23	203-0351	
DRAIN/VENT SCREW			
Stainless Steel 316	21	203-1401	A
Hastelloy C276	21	203-1402	A
Monel 400	21	203-1403	A
FLANGE PLUG (STOPPER)A			
Stainless Steel 316	14	203-0552	
Hastelloy C276	14	203-0553	
Monel 400	14	203-0554	

MOUNTING BRACKET FOR 2" PIPE MOUNTING (NOTE 5)			
Carbon Steel	-	203-0801	
Stainless Steel 316	-	203-0802	
Carbon Steel with bolts, nuts, washers and U-clamp in 316SS	-	203-0803	
LOCAL ADJUSTMENT PROTECTION CAP	9	204-0114	
SENSOR	25	(NOTE 4)	B
DRAIN/VENT VALVE			
316 SST	28		
PLUG			
1/2 NPT Internal Hexagon Plug in Plated CS (Ex d)	27	400-0808	
1/2 NPT Internal Hexagon Plug in 304 SST (Ex d)	27	400-0809	
M20 X 1.5 External Hexagon Plug in 316 SST (Ex d)	27	400-0810	
PG 13.5 External Hexagon Plug in 316 SST (Ex d)	27	400-0811	
1/2 NPT Internal Socket Set Plug in Plated CS	27	400-0583-11	
1/2 NPT Internal Socket Set Plug in 304 SST	27	400-0583-12	
ADAPTER FOR ELECTRIC CONNECTION			
3/4 NPT female for 1/2 NPT male, SST 316	-	400-0812	

NOTE	
<p>1 - For category A, it is recommended to keep, in stock, 25 parts installed for each set, and for category B, 50. 2 - Includes Terminal Block, Screws, caps and Identification plate without certification. 3 - O-rings and Backup Rings are packaged in packs of 12 units, except for spring loaded. 4 - To specify sensors, use the following tables. 5 - Including U-Clamp, nuts, bolts and washers 6 - For this type, O-Ring pack has 1 piece.</p>	

Smar Insulator Kit

The Insulator Kit Smar prevents the generation of galvanic current between metals when in contact. The difference of potential between the metals generates this current that flows from the metal with higher potential to the other. This process in the presence of aqueous solution with salts, acids or bases can start the corrosion process, where the corroded metal is always the one with bigger potential (anode).

In the processes, when it is impossible to isolate the two potencialized metals, occurs the generation of galvanic current. This current will form free ions of hydrogen (H+) in one of the solutions, with tendency to start the corrosion and the migration of the Hydrogen to the diaphragm of the Remote Seal or of the Level Transmitter.

The figure 6.3 shows the following parts that constitute the Smar Insulator Kit: Teflon Gasket (6), Nonmetallic Insulating Sleeve (4), Mica Washers (3) and Steel Washers (2).

Smar Insulator Kit Mounting

Mounting step by step:

- 1 – Insert all the Nonmetallic Insulating Sleeve (4); in the holes of the Sealed Flange (5);
- 2 – Put the Teflon Gasket (6) between the Flanges (5 e 7);
- 3 – Insert the Steel Washers (2) and the Mica Washers (3) in the bolts (1)
- 4 – Join the Flanges positioning its holes (5 and 7);
- 5 – Introduce the bolts in the holes of the flanges (5 and 7) and tighten the flanges with the nuts (8)
- 6 – Measure the resistance between the Sealed Flange (5) and the Flange of Process (7) that should be tending to the infinite to check the efficiency of the Insulator Kit.

NOTE
<p>If the studs are used instead of the bolts, obey the same mounting sequence for the items 2, 3 and 4. This Insulator Kit can be applied with raised and flat face flanges. The Gasket must be made of Teflon when the Smar Insulator Kit is indicated.</p>

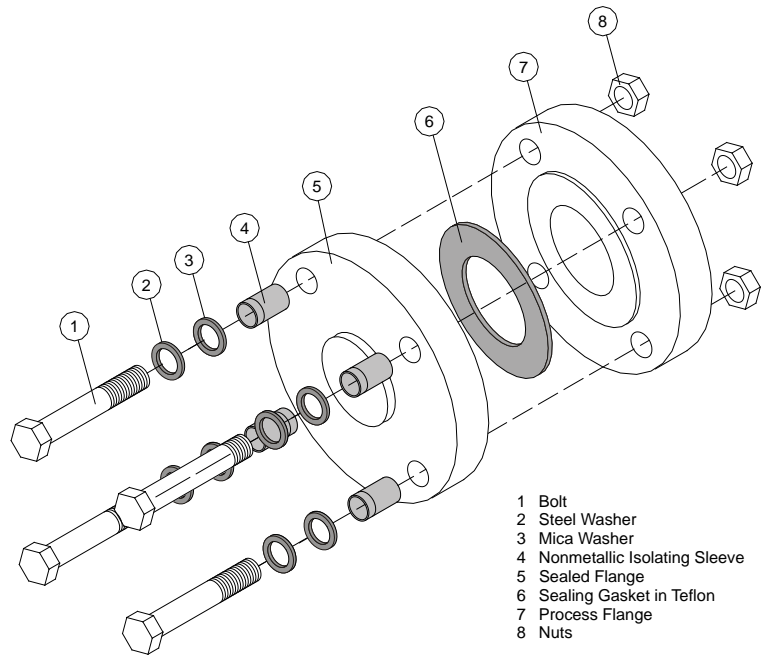

Figure 4.5 – Insulator Kit Mounting

INSULATOR KIT SPARE PARTS: LD300L					
ØN	GROUP	NORM	MODELS WITHOUT	MODELS WITH EXTENSION	
			EXTENSION		
			LD300L / SR301T	LD300L / SR301E	
1"	150	ANSI B 16.5	400-0861-11X01	400-0861-11X11	
	300		400-0861-12X01	400-0861-12X11	
	600		400-0861-13X01	400-0861-13X11	
1.1/2"	150		400-0861-21X01	400-0861-21X11	
	300		400-0861-22X01	400-0861-22X11	
	600		400-0861-23X01	400-0861-23X11	
2"	150		400-0861-31X01	400-0861-31X11	
	300		400-0861-32X01	400-0861-32X11	
	600		400-0861-33X01	400-0861-33X11	
3"	150		400-0861-41X01	400-0861-41X11	
	300		400-0861-42X01	400-0861-42X11	
	600		400-0861-43X01	400-0861-43X11	
4"	150		400-0861-51X01	400-0861-51X11	
	300		400-0861-52X01	400-0861-52X11	
	600		400-0861-53X01	400-0861-53X11	
DN25	PN10/40		DIN EN1092-1	400-0861-64X01	400-0861-64X11
DN40	PN10/40			400-0861-74X01	400-0861-74X11
DN50	PN10/40			400-0861-84X01	400-0861-84X11
DN80	PN10/40	400-0861-94X01		400-0861-94X11	
DN100	PN16	400-0861-A8X01		400-0861-A8X11	
	PN40	400-0861-A4X01		400-0861-A4X11	
40A	20K	IS B 2202	400-0861-B6X01	400-0861-B6X11	
50A	10K		400-0861-C5X01	400-0861-C5X11	
	40K		400-0861-C7X01	400-0861-C7X11	
80A	10K		400-0861-D5X01	400-0861-D5X11	
	20K		400-0861-D6X01	400-0861-D6X11	
100A	10K		400-0861-E5X01	400-0861-E5X11	

Table 4.2 – LD300L – Codes to the Spare parts of the Insulator Kit

See Figure 4.5.

SPARE PARTS: LD300L						
ØN	GROUP	NORM	GASKET			DRAIN VALVE
			TEFLON	COPPER	GRAFOIL	STAINLESS STEEL 316L
1"	ALL	ANSI-B16.5	400-0425	400-0426	400-0427	400-0792
1.1/2"	ALL		400-0428	400-0429	400-0430	
2"	ALL		400-0431	400-0432	400-0433	
3"	ALL		400-0434	400-0435	400-0436	
4"	ALL		400-0437	400-0438	400-0439	
DN25	ALL	EN 1092-1/2501	400-0440	400-0441	400-0442	
DN40	ALL		400-0443	400-0444	400-0445	
DN50	ALL		400-0446	400-0447	400-0448	
DN80	ALL		400-0449	400-0450	400-0451	
DN100	PN10/16		400-0452	400-0453	400-0454	
DN100	PN25/40		400-0455	400-0456	400-0457	

Table 4.3– LD300L – Codes to the Spare parts of the Gasket

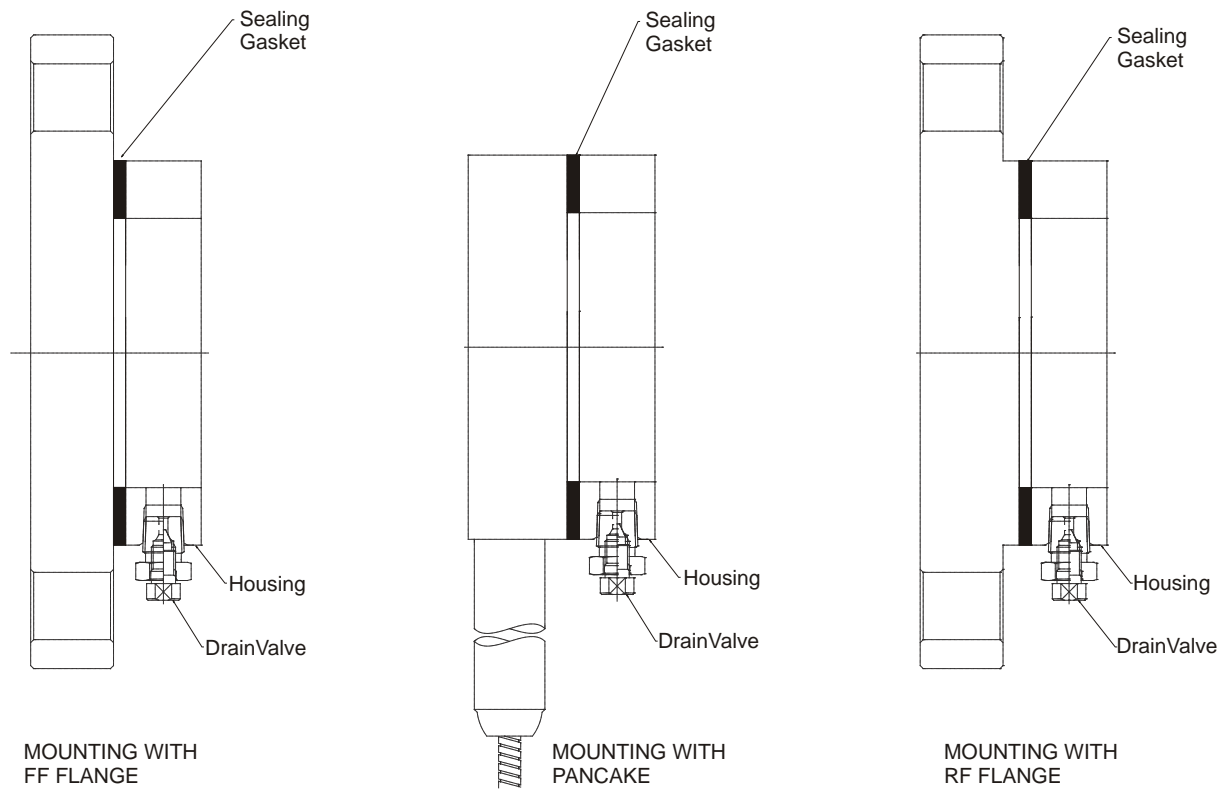

Figure 4.6 – LD300L- Sealing Gasket

RTJ SPARE PARTS: LD300L (without Extension)					
ØN	GROUP	NORM	RING	METALLIC RING	DRAIN VALVE
				STAINLESS STEEL 316L	STAINLESS STEEL 316L
1"	150	ANSI B 16.20 RTJ	R15	400-0887	400-0792
	300		R16	400-0888	
	600		R16	400-0888	
	1500		R16	400-0888	
	2500		R18	400-0889	
1.1/2"	150		R19	400-0890	
	300		R20	400-0891	
	600		R20	400-0891	
	1500		R20	400-0891	
	2500		R23	400-0893	
2"	150		R22	400-0892	
	300		R23	400-0893	
	600		R23	400-0893	
	1500		R24	400-0894	
	2500		R26	400-0895	
3"	150		R29	400-0896	
	300		R31	400-0897	
	600		R31	400-0897	
4"	150		R36	400-0900	
	300		R37	400-0901	
	600	R37	400-0901		

Table 4.4 – LD300L – Codes to the SST Metallic O-Ring

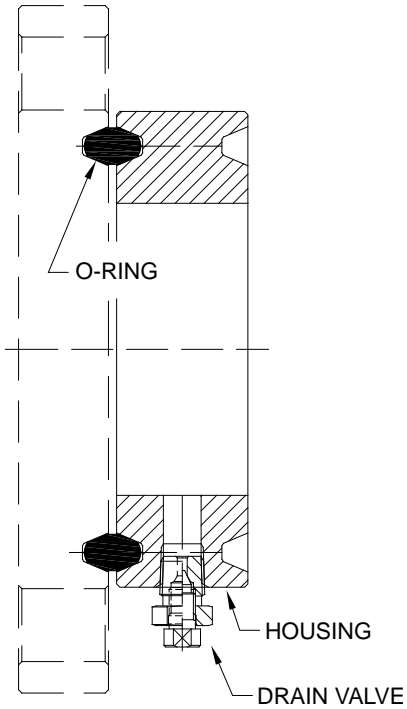

Figure 4.7 – SST Metallic O’Ring

ØN	CLASS	NORM	Ring	METALLIC RING
				316L SST
3"	1500	ANSI B 16.20 RTJ	R35	400-0899
	2500		R32	400-0898
4"	1500		R39	400-0903
	2500		R38	400-0902

Table 4.5 - LD300L – Special models for Gasket in Steel – Without Extension

Application with Halar

Technical Specification

Halar® is chemically one of the most resistant fluoropolymer. It is a thermoplastic of the melting process manufactured by Solvay Solexis, Inc. For its chemical structure, a 1:1 alternating ethylene copolymer and chlorinetrifluoroethylene, Halar® offers an only combination of useful properties.

The diaphragms in 316L Stainless Steel covered with Halar®, are ideal for applications in contact with aggressive liquids. They offer excellent resistance to the chemic and abrasion with a wide temperature range. Halar® does not contaminate liquids of high purity and it is not affected by most of corrosive chemists, usually found in the industries, including strong minerals, oxidant acids, alkalis, liquid oxygen and some organic solvents.

Halar® is trademark of *Solvay Solexis, Inc.*

Performance Specification

For the performance specification see the equation below:

$$[1\% \text{ SPAN} \times (\text{URL}/\text{SPAN})] - \text{Included temperature error}^*$$

Diameters/Capillary Length:

- 2" ANSI B 16.5, DN 50 DIN, JIS 50 A, for seals up to 3 meters of capillary and level models (by inquiry).
- 3" ANSI B 16.5, DN 80 DIN, JIS 80 A, for seals up to 5 meters of capillary and level models.
- 4" ANSI B 16.5, DN 100 DIN, JIS 100 A, for seals up to 8 meters of capillary and level models.

*Temperature Limits:

- +10 to 100°C;
- +101 to 150°C (by inquiry).

TPE – Total Probable Error (Software)

Software to calculate the assembly error of the Pressure Transmitters with the possible connections to the process.

TPE was developed to a fast and effective aid of the products related the pressure measurement. The users are the Applications Engineer and Commercial Areas. The customer can request a report of performance estimate to Smar.

This product allows doing simulations of possible assemblies, verifying important data as the error estimates of the response time, of capillary length analysis and mechanical resistance of diaphragms with temperature variation. See an example in the Figure 5.8.

ETPNet 4.00 - Microsoft Internet Explorer

Address: http://www.smar.net.com.br/etp/calcula/calculo.php

Especificação dos equipamentos

LD300 (após out/2005)

Tipo:	D - Diferencial	ETP requerido:	5 %
Faixa:	Faixa 2 (50 kPa)	Estabilidade:	12 meses
Material do diafragma:	Inox 316	Estabilidade especial:	não
Óleo do sensor:	Silicone	Variação da alimentação:	1 V
Limite de medição:	0 até 50 kPa	Variação de pres. estática:	10 bar
Temperatura mínima:	10 °C	Vácuo:	não
Temperatura máxima:	40 °C		
Temperatura ajuste zero:	(Ajuste de Zero a 25 °C)		

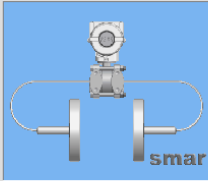

Conexões:

Material do diafragma:	Inox 316	Espessura do diafragma:	Padrão
Óleo de enchimento:	Silicone 200/20	Simetria térmica:	Simétrico
Projeto selo:	Modelo Jun/2008	Diâmetro interno capilar:	1.10 mm [Padrão]

Conexão high: SR301T (Tipo T)

Temp. processo mínima:	10 °C	Temp. processo máxima:	100 °C
Ø Conexão:	3 pol	Temp. capilar mínima:	10 °C
Capilar:	500 cm	Temp. capilar máxima:	40 °C

Conexão low: SR301T (Tipo T)

Temp. processo mínima:	10 °C	Temp. processo máxima:	100 °C
Ø Conexão:	3 pol	Temp. capilar mínima:	10 °C
Capilar:	500 cm	Temp. capilar máxima:	40 °C

Erro total provável

Exatidão:	0.08%	Temperatura mínima:	-0.06%
Estabilidade:	0.15% por 60.0 meses	Temperatura máxima:	0.06%
Pressão estática - zero:	0.00%	Desvio pela alimentação:	0.01%
Pressão estática - span:	0.03%	Tempo do transmissor:	0.1 s
ETP do transmissor para temp. mínimas:	0.10%	ETP do transmissor para temp. máximas:	0.10%
Temperatura lado high mínima:	-0.30%	Temperatura lado low mínima:	-0.30%
Temperatura lado high máxima:	0.49%	Temperatura lado low máxima:	0.49%

ETP	Temp. mínima	Temp. máxima
Erro Selo/nível para:	0.17%	0.28%

Done Intranet local

Figure 4.8 – TPE Software Screen

Ordering Code for the Sensor

204 - 0301 SENSOR FOR DIFFERENTIAL , FLOW, GAGE, ABSOLUTE AND HIGH STATIC PRESSURE TRANSMITTER										
COD	Type	Range Limits		Min. Span	Unit	Range Limits		Min. Span	Unit	
		Min.	Max.			Min.	Max.			
D0	Differential and Flow	-1	1	0.05	kPa	-4	4	0.2	inH ₂ O	NOTE: The range can be extended up to 0.75 LRL* and 1.2 URL* with small degradation of accuracy. *LRL = Lower Range Limit. *URL = Upper Range Limit.
D1	Differential and Flow	-5	5	0.13	kPa	-20	20	0.5	inH ₂ O	
D2	Differential and Flow	-50	50	0.42	kPa	-200	200	1.67	inH ₂ O	
D3	Differential and Flow	-250	250	2.08	kPa	-36	36	0.3	psi	
D4	Differential and Flow	-2500	2500	20.83	kPa	-360	360	3	psi	
M0	Gage	-1	1	0.05	kPa	-4	4	0.2	inH ₂ O	
M1	Gage	-5	5	0.13	kPa	-20	20	0.5	inH ₂ O	
M2	Gage	-50	50	0.42	kPa	-200	200	1.67	inH ₂ O	
M3	Gage	-100	250	2.08	kPa	-14.50	36	0.3	psi	
M4	Gage	-100	2500	20.83	kPa	-14.50	360	3	psi	
M5	Gage	-0.1	25	0.21	Mpa	-14.50	3600	30	psi	
M6	Gage	-0.1	40	0.33	Mpa	-14.50	5800	48.3	psi	
A1	Absolute	0	5	2.00	kPa	0	37	14.8	mmHg	
A2	Absolute	0	50	2.50	kPa	0	7.2	0.36	psia	
A3	Absolute	0	250	5.00	kPa	0	36	0.73	psia	
A4	Absolute	0	2500	20.83	kPa	0	360	3	psia	
A5	Absolute	0	25	0.21	Mpa	0	3600	30	psia	
A6	Absolute	0	40	0.33	Mpa	0	5800	48.3	psia	
H2	Differential – High Static Pressure	-50	50	0.42	kPa	-200	200	1.67	inH ₂ O	
H3	Differential – High Static Pressure	-250	250	2.08	kPa	-36	36	0.3	psi	
H4	Differential – High Static Pressure	-2500	2500	20.83	kPa	-360	360	3	psi	
H5	Differential – High Static Pressure	-25	25	0.21	Mpa	-3600	-3600	30	psi	
Diaphragm Material and Fill Fluid										
1	316 SST	Silicone Oil (4)	8	Tantalum	Inert Oil Fluorolube (2)(3)(5)	K	Monel 400	Inert Oil Krytox (1) (3) (5)		
2	316 SST	Inert Oil Fluorolube (2) (5)	9	316L SST	Fomblim Oil	M	Monel 400 Gold Plated	Silicone Oil (1) (3) (4)		
3	Hastelloy C276	Silicone Oil (1) (4)	A	Monel 400	Fomblim Oil (1) (3)	P	Monel 400 Gold Plated	Inert Oil Krytox (1) (3) (5)		
4	Hastelloy C276	Inert Oil Fluorolube (1)(2)(5)	D	316L SST	Inert Oil Krytox (3) (5)	Q	316 SST	Inert Oil Halocarbon 4.2 (2) (3) (5)		
5	Monel 400	Silicone Oil (1) (3) (4)	E	Hastelloy C276	Inert Oil Krytox (1) (3) (5)	R	Hastelloy C276	Inert Oil Halocarbon 4.2 (2) (3) (5)		
7	Tantalum	Silicone Oil (3) (4)	G	Tantalum	Inert Oil Krytox (3) (5)	S	Tantalum	Inert Oil Halocarbon 4.2 (2) (3) (5)		

204 - 0301 D2 1 ← TYPICAL MODEL NUMBER

- NOTES**
- (1) Meets NACE MR - 01 - 75/ISO 15156 recommendations.
 - (2) Not available for absolute models nor for vacuum applications.
 - (3) Not available for range 0 and 1.
 - (4) Silicone Oil is not recommended for oxygen (O₂) or Chlorine service.
 - (5) Inert Fluid: Oxygen Compatibility, safe for oxygen service.

204-0301 SENSOR FOR FLANGED PRESSURE TRANSMITTER										
COD.	Range Limits		Min. Span	Unit	Range Limits		Min. Span	Unit	<p>Note: The range can be extended up to 0.75 LRL and 1.2 URL with small degradation of accuracy. The upper range value must be limited to the flange rating.</p>	
	Min.	Max.			Min.	Max.				
L2	-50	50	1.25	kPa	-200	200	5	inH ₂ O		
L3	-250	250	2.08	kPa	-36	36	0.3	psi		
L4	-2500	2500	20.83	kPa	-360	360	3	psi		
L5	-25000	25000	208.3	kPa	-3625	3625	30.2	psi		
COD. Diaphragm material and Fill Fluid (Low Side)										
1	316L SST	Silicone Oil (2)		D	316L SST	Inert Oil Krytox (15)				
2	316L SST	Inert Oil Fluorolube (3) (15)		E	Hastelloy C276	Inert Oil Krytox (1) (15)				
3	Hastelloy C276	Silicone Oil (1) (2)		G	Tantalum	Inert Oil Krytox (15)				
4	Hastelloy C276	Inert Oil Fluorolube(1)(3)(15)		K	Monel 400	Inert Oil Krytox (1) (15)				
5	Monel 400	Silicone Oil (1) (2)		M	Monel 400 Gold Plated	Silicone Oil (1) (2)				
7	Tantalum	Silicone Oil (2)		P	Monel 400 Gold Plated	Inert Oil Krytox (1) (15)				
8	Tantalum	Inert Oil Fluorolube (3) (15)		Q	316L SST	Inert Oil Halocarbon 4.2 (15)				
9	316L SST	Fomblim Oil		R	Hastelloy C276	Inert Oil Halocarbon 4.2 (1) (15)				
A	Monel 400	Fomblim Oil (1)		S	Tantalum	Inert Oil Halocarbon 4.2 (15)				
COD. Flange, Adapter and Drain/Vent Valves material (Low Side)										
A	304L SST			M	Monel 400 (1)					
C	Plated CS (Drain/Vent in Stainless Steel) (16)			N	316 SST – CF8M (ASTM – A351) (Drain/Vent in Hastelloy C276) (1)					
H	Hastelloy C276 (CW – 12MW, ASTM – A494) (1)			P	316 SST – CF8M (ASTM – A351) Flange with PVDF (Kynar) insert (3) (4) (5)					
I	316 SST – CF8M (ASTM – A351)									
COD. Wetted O'Ring Material (Low Side)										
0	Without O'Rings		K	Kalrez						
B	Buna N		T	Teflon	Note: O'rings are not available on the sides with remote seals.					
E	Ethylene – Propylene		V	Viton						
COD. Drain/Vent Position (Low Side)										
0	Without Drain/Vent		D	Bottom	Note: For better Drain/Vent operation, vent valves are strongly recommended.					
A	Drain/Vent (Opposite to Process Connection)		U	Top	Drain/Vent valve not available on the sides with remote seals.					
COD. Process Connection (Low Side)										
0	1/2 - 18 NPT (Without Adapter)		5	1/2 - 14 NPT Axial with PVDF Insert (3) (4) (6)		U Low Volume Flange For Level Welded				
1	1/2 - 14 NPT (Without Adapter)		9	Remote Seal (Low Volume Flange) (3) (7)		V Without Connection (Mounting With Gage Flange)				
3	Remote Seal (With Plug) (7)		T	1/2 14 BSP (With Adapter)		W Without Connection (Absolut Reference)				
COD. Process Connection (Level Tap)										
U	1" 150 # (ANSI B16.5) (18)		C	3" 600 # (ANSI B16.5)		S JIS 40A 20K (17)				
V	1" 300 # (ANSI B16.5) (18)		N	3" 600 # (ANSI B16.5 RTJ)		F JIS 50A 10K (17)				
W	1" 600 # (ANSI B16.5) (18)		3	4" 150 # (ANSI B16.5)		T JIS 50A 40K (17)				
O	1.1/2" 150 # (ANSI B16.5)		4	4" 300 # (ANSI B16.5)		K JIS 50A 20K (17)				
P	1.1/2" 300 # (ANSI B16.5)		D	4" 600 # (ANSI B16.5)		G JIS 80A 10K (17)				
Q	1.1/2" 600 # (ANSI B16.5)		5	DN 25 PN 10/40 (18)		L JIS 80A 20K (17)				
9	2" 150 # (ANSI B16.5)		R	DN 40 PN 10/40		H JIS 100A 10K (17)				
A	2" 300 # (ANSI B16.5)		E	DN 50 PN 10/40		M JIS 100A 10K (17)				
B	2" 600 # (ANSI B16.5)		6	DN 80 PN 10/40		Z User's specification				
1	3" 150 # (ANSI B16.5)		7	DN 100 PN 10/16						
2	3" 300 # (ANSI B16.5)		8	DN 100 PN 25/40						
COD. Type and Flange Material (Level Tap)										
2	316 SST (Integral Flange)		4	304 SST (Slip-on Flange)		6 Carbon Steel (Slip-on Flange)				
3	Hastelloy C276 (Integral Flange)		5	316 SST (Slip-on Flange)		Z User's specification				
COD. Extension Length										
0	0 mm (0")		3	150 mm (6")		Note: Extension Material 316 SST				
1	50 mm (2")		4	200 mm (8")						
2	100 mm (4")		Z	User's specification						
COD. Diaphragm Material / Extension (Level Tap)										
A	304L SST / 304L SST		6	316L SST with Teflon Lining (For 2" and 3")						
1	316L SST / 316 SST		7	316L SST Gold Plated						
2	Hastelloy C276 / 316 SST		B	Tantalum with Teflon Lining						
3	Monel 400 / 316 SST		L	316L SST Halar Plated (14)						
4	Tantalum / 316 SST (9)		C	Hastelloy Teflon Plated						
5	Titanium / 316 SST (9)									
COD. Fill Fluid										
1	DC – 200/20 Silicone Oil		G	Glycerin + water (11)						
3	DC704 Silicone Oil		B	Fomblim 06/06						
2	MO – 10 Fluorolube Oil (8)		H	Halocarbon 4.2						
4	Krytox Oil		T	Syltherm 800 Oil						
N	Neobee M20 Propylene Glycol Oil									
COD. Housing Material										
0	Without Housing (11)									
1	316 SST									
2	Hastelloy C276									
3	Super Duplex (UNS 32750) (10)									
4	Duplex (UNS 31803) (10)									
5	304L SST (10)									
COD. Gasket Material										
0	Without Gasket									
T	Teflon (PTFE)									
G	Grafoil (Flexible lead)									
C	Copper									
I	316 L SST									

204-0301 L2 1 I B U 0 1 2 2 1 1 1 1 T ← TYPICAL MODEL NUMBER

204-0301	SENSOR FOR FLANGED PRESSURE TRANSMITTER (CONTINUATION)	
	CODE	Flanges Bolts and Nuts Material
	A0	Plated Carbon Steel (Default) (16)
	A1	316 SST
	A2	Carbon Steel (ASTM A193 B7M) (1) (16)
	A5	Hastelloy C276
	CODE	Flange thread for fixing accessories (adapters, manifolds, mounting brackets, etc)
	D0	7/16" UNF (Default)
	D1	M10 X 1.5
	D2	M12 X 1.75
	CODE	Flange Facing Finish
	Q0	Raised Face – RF (Default)
	Q1	Flat Face – FF
	Q2	Ring Joint Face – RTJ (Only available for ANSI standard flange) (12)
	Q3	Tongue Face (11)
	Q4	Grooved Face (11)

204-0301 | A0 | D0 | Q0 ← TYPICAL MODEL NUMBER

NOTES

- | | |
|--------------------------------------------------------------------------------------------------------------------------------------------------------------------------------------------------------------------------------------------------------------------------------------------------------------------------------------------------------------------------------------------------------------------------------------------------------------------------------------------------------------------------------------------------------------------------------------------------------------------------------------------------------------------------------------------------------------------------------------------------------------------------------------------------------------------------------|------------------------------------------------------------------------------------------------------------------------------------------------------------------------------------------------------------------------------------------------------------------------------------------------------------------------------------------------------------------------------------------------------------------------------------------------------------------------------------------------------------------------------------------------------------------------------------------------------------------------------------------------------------------------------------------------------------------------------------------------------------------------------------------------------------------------------------------------------------------|
| <p>(1) Meets NACE MR – 01 – 75/ISO 15156 recommendations.</p> <p>(2) Silicone Oils not recommendations for Oxygen (O₂) or Chlorine service.</p> <p>(3) Not applicable for vacuum service.</p> <p>(4) Drain/Vent not applicable.</p> <p>(5) O'Ring should be Viton or Kalrez.</p> <p>(6) Maximum pressure 24 bar.</p> <p>(7) For remote Seal only 316 SST - CF8M (ASTM A3510 flange is available (thread M12).</p> <p>(8) Fluorolube fill fluid is not available for Monel diaphragm.</p> <p>(9) Attention, check corrosion rate for the process, tantalum plate 0.1 mm, AISI 316L extension 3 to 6mm.</p> <p>(10) Item by inquiry.</p> <p>(11) Supplied without Gasket.</p> <p>(12) Gasket for housing, available only in Stainless 316.</p> <p>(13) Range of application of temperature from -40 °C to 150 °C.</p> | <p>(14) Applicable only to:</p> <ul style="list-style-type: none"> - Thickness of steel: 0.05 mm - Diameter/capillary length: <ul style="list-style-type: none"> 2" ANSI B 16.5 DN 50 DIN, JIS 50 A, for seals up to 3 meters of capillary and level models (by inquiry). 3" ANSI B 16.5 DN 80 DIN, JIS 80 A, for seals up to 5 meters of capillary and level models. - Faces: RF and FF; - Temperature Range: +10 to 100 °C
+ 101 to 150 °C (by inquiry) - Not applicable for diaphragm thickness; - Not applicable for use with gaskets. <p>(15) Inert Fluid: safe for oxygen service.</p> <p>(16) Not applicable for saline atmosphere.</p> <p>(17) Not available for slip-on flange.</p> <p>(18) Not available for integral flange.</p> |
|--------------------------------------------------------------------------------------------------------------------------------------------------------------------------------------------------------------------------------------------------------------------------------------------------------------------------------------------------------------------------------------------------------------------------------------------------------------------------------------------------------------------------------------------------------------------------------------------------------------------------------------------------------------------------------------------------------------------------------------------------------------------------------------------------------------------------------|------------------------------------------------------------------------------------------------------------------------------------------------------------------------------------------------------------------------------------------------------------------------------------------------------------------------------------------------------------------------------------------------------------------------------------------------------------------------------------------------------------------------------------------------------------------------------------------------------------------------------------------------------------------------------------------------------------------------------------------------------------------------------------------------------------------------------------------------------------------|

204-0301 SENSOR FOR SANITARY PRESSURE TRANSMITTER										
COD.	Range Limits		Min. Span	Unit	Range Limits		Min. Span	Unit	Note: The range can be extended up to 0.75 LRL and 1.2 URL with small degradation of accuracy. The upper range value must be limited to the flange rating.	
	Min.	Max.			Min.	Max.				
S2	-50	50	1.25	kPa	-200	200	5	inH ₂ O		
S3	-250	250	2.08	kPa	-36	36	0.3	psi		
S4	-2500	2500	20.83	kPa	-360	360	3	psi		
S5	-25000	25000	208.3	kPa	-3625	3625	30.2	psi		
COD. Diaphragm material and Fill Fluid (Low Side)										
1	316L SST	Silicone Oil (2)		D	316L SST	Inert Oil Krytox (12)				
2	316L SST	Inert Oil Fluorolube (3) (12)		E	Hastelloy C276	Inert Oil Krytox (1) (12)				
3	Hastelloy C276	Silicone Oil (1) (2)		G	Tantalum	Inert Oil Krytox (12)				
4	Hastelloy C276	Inert Oil Fluorolube(1)(3)(12)		K	Monel 400	Inert Oil Krytox (1) (12)				
5	Monel 400	Silicone Oil (1) (2)		M	Monel 400 Gold Plated	Silicone Oil (1) (2)				
7	Tantalum	Silicone Oil (2)		P	Monel 400 Gold Plated	Inert Oil Krytox (1) (12)				
8	Tantalum	Inert Oil Fluorolube (3) (12)		Q	316L SST	Inert Oil Halocarbon 4.2 (12)				
9	316L SST	Fomblim Oil		R	Hastelloy C276	Inert Oil Halocarbon 4.2 (1) (12)				
A	Monel 400	Fomblim Oil (1)		S	Tantalum	Inert Oil Halocarbon 4.2 (12)				
COD. Flange, Adapter and Drain/Vent Valves Material (Low Side)										
C	Plated CS (Drain/Vent in Stainless Steel) (13)				M	Monel 400 (1)				
H	Hastelloy C276 (CW – 12MMV, ASTM – A494) (1)				N	316 SST – CF8M (ASTM – A351) (Drain/Vent in Hastelloy C276) (1)				
I	316 SST – CF8M (ASTM – A351)				P	316 SST – CF8M (ASTM – A351) Flange with PVDF (Kynar) insert (3) (4) (5)				
COD. Wetted O'Ring Material (Low Side)										
0	Without O'Rings			K	Kalrez					
B	Buna-N			T	Teflon					
E	Ethylene – Propylene			V	Viton					
Note: O'rings are not available on the sides with remote seals.										
COD. Drain/Vent Position (Low Side)										
0	Without Drain/Vent				D	Bottom				
A	Drain/Vent (Opposite to Process Connection)				U	Top				
Note: For better Drain/Vent operation, vent valves are strongly recommended. Drain/Vent valve not available on the sides with remote seals.										
COD. Process Connection (Low Side)										
0	1/4 - 18 NPT (Without Adapter)				5	1/2 - 14 NPT Axial with PVDF Insert (3) (4) (6)				
1	1/2 - 14 NPT (Without Adapter)				9	Remote Seal (Low Volume Flange) (3) (7)				
3	Remote Seal (With Plug) (7)				T	1/2 14 BSP (With Adapter)				
U	Low Volume Flange For Level Welded									
V	Without Connection (Mounting with Gage Flange)									
W	Without Connection (Absolut Reference)									
COD. Process Connection (Level tap)										
8	Threaded DN25 DIN 11851 – with extension / 316L SST (9)(10)				E	Threaded SMS 2" – without extension / 316L SST (9) (10)				
9	Threaded DN40 DIN 11851 - with extension / 316L SST (9)(10)				M	Threaded SMS 3" - with extension / 316L SST (9) (10)				
H	Threaded DN40 DIN 11851 – without extension / 316L SST (9)				1	Threaded SMS 3" - without extension / 316L SST (9) (10)				
V	Threaded DN50 DIN 11851 - with extension / 316L SST (9)(10)				F	Tri-Clamp 1 1/2" – without extension / 316L SST (10)				
U	Threaded DN50 DIN 11851 - without extension / 316L SST (9)				Q	Tri-Clamp 1 1/2" HP (High Pressure) - without extension/ 316L SST n (8) (10)				
X	Threaded DN80 DIN 11851 - with extension / 316L SST (9)(10)				6	Tri-Clamp 2" - with extension / 316L SST (10)				
W	Threaded DN80 DIN 11851 - without extension / 316L SST (9)				D	Tri-Clamp 2" – without extension / 316L SST (10)				
4	Threaded IDF 2" - with extension / 316L SST (9) (10)				N	Tri-Clamp 2" HP (High Pressure) - with extension / 316L SST (8) (10)				
B	Threaded IDF 2" – without extension / 316L SST (9) (10)				P	Tri-Clamp 2" HP (High Pressure) – without extension / 316L SST (8) (10)				
K	Threaded IDF 3" - with extension / 316L SST (9) (10)				I	Tri-Clamp 3" - with extension / 316L SST (10)				
3	Threaded IDF 3" - without extension / 316L SST (9) (10)				G	Tri-Clamp 3" – without extension / 316L SST (10)				
5	Threaded RJT 2" - with extension / 316L SST (9) (10)				J	Tri-Clamp 3" HP (High Pressure) - with extension / 316L SST (8) (10)				
C	Threaded RJT 2" - without extension / 316L SST (9)				R	Tri-Clamp 3" HP (High Pressure) – without extension o (8) (10)				
L	Threaded RJT 3" - with extension / 316L SST (9) (10)				Z	User's specification				
2	Threaded RTJ 3" - without extension / 316L SST (9)									
S	Threaded SMS 1 1/2" – without extension / 316L SST (9) (10)									
7	Threaded SMS 2" - with extension / 316L SST (9) (10)									
COD. Diaphragm Material (Level Tap)										
1	316L SST				6	316L SST with Teflon Lining (For 2" and 3")				
2	Hastelloy C276				7	316L SST Gold Plated				
3	Monel 400				B	Tantalum with Teflon Lining				
4	Titanium (11)				L	316L SST Halar Plated (20)				
5	Titanium (11)				C	Hastelloy Teflon Plated				
COD. Fill Fluid										
1	DC – 200/20 Silicone Oil				G	Glycerin + water (11)				
3	DC704 Silicone Oil				B	Fomblim 06/06				
2	MO – 10 Fluorolube Oil (8)				H	Halocarbon 4.2				
4	Krytox Oil				T	Syltherm 800 Oil				
N	Neobee M20 Propylene Glycol Oil (Approved 3A) (10)									

204-0301 L2 1 I B U 0 1 2 2

◆ TYPICAL MODEL NUMBER

204-0301		SENSOR FOR SANITARY PRESSURE TRANSMITTER (CONTINUATION)	
CODE		Flanges Bolts and Nuts Material	
A0	Plated Carbon Steel (Default) (13)	A5	Hastelloy C276
A1	316 SST		
A2	Carbon Steel (ASTM A193 B7M) (1) (13)		
CODE		Flange thread for fixing accessories (adapters, manifolds, mounting brackets, etc)	
D0	7/16" UNF (Default)	D2	M12 X 1.75
D1	M10 X 1.5		

204-0301	A0	D0	← TYPICAL MODEL NUMBER
----------	----	----	------------------------

- NOTES**
- (1) Meets NACE MR – 01 – 75/ISO 15156 recommendations.
 - (2) Silicone Oils not recommendations for Oxygen (O₂) or Chlorine service.
 - (3) Not applicable for vacuum service.
 - (4) Drain/Vent not applicable.
 - (5) O’Ring should be Viton or Kalrez.
 - (6) Maximum pressure 24 bar.
 - (7) For remote Seal only 316 SST - CF8M (ASTM A3510 flange is available (thread M12).
 - (8) HP – High Pressure
 - (9) Not available for tri-clamp connections.
 - (10) Compliant with 3A-7403 standard for food and other applications where sanitary connections are required.:
 - Neobee M2O Fill Fluid
 - Finishing wet Face: 0,8 µm Ra (32 µ" AA)
 - Wet O-Ring: Viton, Buna-N and Teflon
 - (11) Item by inquire.
 - (12) Inert Fluid: Oxygen Compatibility, safe for oxygen service.
 - (13) Not applicable for saline atmosphere.

TECHNICAL CHARACTERISTIC

Functional Specifications																																																																									
Process Fluid	Liquid, gas or vapor.																																																																								
Output	Digital only. Complies with IEC 61158-2 (H1): 31.25kbit/s voltage mode, bus powered.																																																																								
Power Supply	Bus powered: 9 – 32 Vdc. Quiescent current consumption: 12 mA																																																																								
Indicator	4 1/2-digit numerical and 5-character alphanumeric LCD indicator (optional).																																																																								
Hazardous Area Certifications	Explosion proof (FM, CSA, NEMKO, CEPEL), intrinsic safe (FM, CSA, NEMKO, EXAM, CEPEL, NEPSI), dust ignition proof and non-incendive (FM). FISCO Field Device Ex ia IIC T4 (FM, CSA, NEMKO, EXAM, CEPEL, NEPSI) FNICO Field Device Ex n1 IIC T4 (FM, CSA, NEMKO, EXAM, CEPEL)																																																																								
European Directive Information	<p>Authorized representative in European Community Smar GmbH-Rheingaustrasse 9-55545 Bad Kreuznach</p> <p>PED Directive (97/23/EC) – Pressure Equipment Directive This product is in compliance with the directive and it was designed and manufactured in accordance with sound engineering practice using several standards from ANSI, ASTM, DIN and JIS.</p> <p>EMC Directive (2004/108/EC) - Eletromagnetic Compatibility The EMC test was performed according to IEC standard: IEC61326-1:2006, IEC61326-2-3:2006, IEC61000-6-4:2006, IEC61000-6-2:2005. For use in environment only. Keep the shield insulated at the instrument side, connecting the other one to the ground if necessary to use shielded cable.</p> <p>ATEX Directive (94/9/EC) – Equipment and protective systems intended for use in potentially explosive atmospheres This product was certified according European Standards at NEMKO and EXAM (old DMT). The certified body for manufacturing quality assessment is EXAM (number 0158).</p> <p>LVD Directive 2006/95/EC – Electrical Equipment designed for use within certain voltage limits According the LVD directive Annex II the equipment under ATEX “Electrical equipment for use in an explosive atmosphere” directive are excluded from scope from this directive. The EC declarations of conformity for all applicable European directives for this product can be found at www.smar.com.</p>																																																																								
Zero and Span Adjustments	Noninteractive, via digital communication.																																																																								
Failure Alarm (Diagnostics)	For sensor circuit failures, events are generated and status is sent to link outputs. Detailed diagnostics are available in the contained parameters.																																																																								
Temperature Limits	<table border="0"> <tr> <td>Ambient:</td> <td>-40</td> <td>to</td> <td>85 °C</td> <td>(-40</td> <td>to</td> <td>185 °F)</td> <td></td> </tr> <tr> <td>Process:</td> <td>-40</td> <td>to</td> <td>100 °C</td> <td>(-40</td> <td>to</td> <td>212 °F)</td> <td>(Silicone oil)</td> </tr> <tr> <td></td> <td>0</td> <td>to</td> <td>85 °C</td> <td>(32</td> <td>to</td> <td>185 °F)</td> <td>(Halocarbon and Fluorolube oil)</td> </tr> <tr> <td></td> <td>-20</td> <td>to</td> <td>85 °C</td> <td>(-4</td> <td>to</td> <td>185 °F)</td> <td>(Krytox oil and Fomblim oil)</td> </tr> <tr> <td></td> <td>-25</td> <td>to</td> <td>85 °C</td> <td>(-13</td> <td>to</td> <td>185 °F)</td> <td>(Viton O-ring)</td> </tr> <tr> <td></td> <td>-40</td> <td>to</td> <td>150 °C</td> <td>(-40</td> <td>to</td> <td>302 °F)</td> <td>(LD302L)</td> </tr> <tr> <td>Storage:</td> <td>-40</td> <td>to</td> <td>100 °C</td> <td>(-40</td> <td>to</td> <td>212 °F)</td> <td></td> </tr> <tr> <td>Display:</td> <td>-20</td> <td>to</td> <td>80 °C</td> <td>(-4</td> <td>to</td> <td>176 °F)</td> <td></td> </tr> <tr> <td></td> <td>-40</td> <td>to</td> <td>85 °C</td> <td>(-40</td> <td>to</td> <td>185 °F)</td> <td>(Without damage)</td> </tr> </table>	Ambient:	-40	to	85 °C	(-40	to	185 °F)		Process:	-40	to	100 °C	(-40	to	212 °F)	(Silicone oil)		0	to	85 °C	(32	to	185 °F)	(Halocarbon and Fluorolube oil)		-20	to	85 °C	(-4	to	185 °F)	(Krytox oil and Fomblim oil)		-25	to	85 °C	(-13	to	185 °F)	(Viton O-ring)		-40	to	150 °C	(-40	to	302 °F)	(LD302L)	Storage:	-40	to	100 °C	(-40	to	212 °F)		Display:	-20	to	80 °C	(-4	to	176 °F)			-40	to	85 °C	(-40	to	185 °F)	(Without damage)
Ambient:	-40	to	85 °C	(-40	to	185 °F)																																																																			
Process:	-40	to	100 °C	(-40	to	212 °F)	(Silicone oil)																																																																		
	0	to	85 °C	(32	to	185 °F)	(Halocarbon and Fluorolube oil)																																																																		
	-20	to	85 °C	(-4	to	185 °F)	(Krytox oil and Fomblim oil)																																																																		
	-25	to	85 °C	(-13	to	185 °F)	(Viton O-ring)																																																																		
	-40	to	150 °C	(-40	to	302 °F)	(LD302L)																																																																		
Storage:	-40	to	100 °C	(-40	to	212 °F)																																																																			
Display:	-20	to	80 °C	(-4	to	176 °F)																																																																			
	-40	to	85 °C	(-40	to	185 °F)	(Without damage)																																																																		
Turn-on Time	Performs within specifications in less than 10 seconds after power is applied to the transmitter.																																																																								
Configuration	Basic configuration may be done using the local adjustment magnetic tool if device is fitted with display. Complete configuration is possible using configuration tools.																																																																								
Volumetric Displacement	Less than 0.15 cm ³ (0.01 in ³)																																																																								

Functional Specifications

From 3.45 kPa abs. (0.5 psia)* to:
 70 psi (5 bar) for range 0
 1200 psi (80 bar) for range 1
 2300 psi (160 bar) for ranges 2, 3 and 4
 4600 psi (320 bar) for models H2 and H5
 5800 psi (400 bar) for range 5
 7500 psi (520 bar) for range 6
***except the LD301A model**

Flange Test Pressure: 68.95 MPa (10,000 psi)
 Overpressures above will not damage the transmitter, but a new calibration may be necessary.

WARNING

It is described here only the maximum pressures of the materials referenced in each rule, it can not be manufactured on request.

Temperatures above 150 ° C are not available in standard models.

PRESSURES TABLE FOR SEAL AND LEVEL FLANGES DIN EN 1092-1 2008 STANDARD

Material Group	Pressure Class	Maximum Temperature Allowed						
		RT	100	150	200	250	300	350
		Maximum Pressure Allowed (bar)						
10E0 AISI 304/304L	PN 16	16	13.7	12.3	11.2	10.4	9.6	9.2
	PN 25	25	21.5	19.2	17.5	16.3	15.1	14.4
	PN 40	40	34.4	30.8	28	26	24.1	23
	PN 63	63	63	57.3	53.1	50.1	46.8	45
	PN 100	100	86.1	77.1	70	65.2	60.4	57.6
	PN 160	160	137.9	123.4	112	104.3	96.7	92.1
	PN 250	250	215.4	192.8	175	163	151.1	144

Material Group	Pressure Class	Maximum Temperature Allowed						
		RT	100	150	200	250	300	350
		Maximum Pressure Allowed (bar)						
14E0 AISI 316/316L	PN 16	16	16	14.5	13.4	12.7	11.8	11.4
	PN 25	25	25	22.7	21	19.8	18.5	17.8
	PN 40	40	40	36.3	33.7	31.8	29.7	28.5
	PN 63	63	63	57.3	53.1	50.1	46.8	45
	PN 100	100	100	90.9	84.2	79.5	74.2	71.4
	PN 160	160	160	145.5	134.8	127.2	118.8	114.2
	PN 250	250	250	227.3	210.7	198.8	185.7	178.5

Material Group	Pressure Class	Maximum Temperature Allowed						
		RT	100	150	200	250	300	350
		Maximum Pressure Allowed (bar)						
16E0 1.4410 Super Duplex 1.4462 Duplex	PN 16	16	16	16	16	16	-	-
	PN 25	25	25	25	25	25	-	-
	PN 40	40	40	40	40	40	-	-
	PN 63	63	63	63	63	63	-	-
	PN 100	100	100	100	100	100	-	-
	PN 160	160	160	160	160	160	-	-
	PN 250	250	250	250	250	250	-	-

PRESSURES TABLE FOR SEAL AND LEVEL FLANGES ASME B16.5 2009 STANDARD

Material Group	Pressure Class	Maximum Temperature Allowed								
		-29 to 38	50	100	150	200	250	300	325	350
		Maximum Pressure Allowed (bar)								
Hastelloy C276	150	20	19.5	17.7	15.8	13.8	12.1	10.2	9.3	8.4
	300	51.7	51.7	51.5	50.3	48.3	46.3	42.9	41.4	40.3
	400	68.9	68.9	68.7	66.8	64.5	61.7	57	55	53.6
	600	103.4	103.4	103	100.3	96.7	92.7	85.7	82.6	80.4
	900	155.1	155.1	154.6	150.6	145	139	128.6	124	120.7
	1500	258.6	258.6	257.6	250.8	241.7	231.8	214.4	206.6	201.1
	2500	430.9	430.9	429.4	418.2	402.8	386.2	357.1	344.3	335.3

Overpressure and Static Pressure Limits (MWP – Maximum Working Pressure)

Functional Specifications

Material Group	Pressure Class	Maximum Temperature Allowed								
		-29 to 38	50	100	150	200	250	300	325	350
S31803 Duplex S32750 Super Duplex	150	20	19.5	17.7	15.8	13.8	12.1	10.2	9.3	8.4
	300	51.7	51.7	50.7	45.9	42.7	40.5	38.9	38.2	37.6
	400	68.9	68.9	67.5	61.2	56.9	53.9	51.8	50.9	50.2
	600	103.4	103.4	101.3	91.9	85.3	80.9	77.7	76.3	75.3
	900	155.1	155.1	152	137.8	128	121.4	116.6	114.5	112.9
	1500	258.6	258.6	253.3	229.6	213.3	202.3	194.3	190.8	188.2
	2500	430.9	430.9	422.2	382.7	355.4	337.2	323.8	318	313.7

Material Group	Pressure Class	Maximum Temperature Allowed								
		-29 to 38	50	100	150	200	250	300	325	350
AISI316L	150	15.9	15.3	13.3	12	11.2	10.5	10	9.3	8.4
	300	41.4	40	34.8	31.4	29.2	27.5	26.1	25.5	25.1
	400	55.2	53.4	46.4	41.9	38.9	36.6	34.8	34	33.4
	600	82.7	80	69.6	62.8	58.3	54.9	52.1	51	50.1
	900	124.1	120.1	104.4	94.2	87.5	82.4	78.2	76.4	75.2
	1500	206.8	200.1	173.9	157	145.8	137.3	130.3	127.4	125.4
	2500	344.7	333.5	289.9	261.6	243	228.9	217.2	212.3	208.9

Material Group	Pressure Class	Maximum Temperature Allowed								
		-29 to 38	50	100	150	200	250	300	325	350
AISI316	150	19	18.4	16.2	14.8	13.7	12.1	10.2	9.3	8.4
	300	49.6	48.1	42.2	38.5	35.7	33.4	31.6	30.9	30.3
	400	66.2	64.2	56.3	51.3	47.6	44.5	42.2	41.2	40.4
	600	99.3	96.2	84.4	77	71.3	66.8	63.2	61.8	60.7
	900	148.9	144.3	126.6	115.5	107	100.1	94.9	92.7	91
	1500	248.2	240.6	211	192.5	178.3	166.9	158.1	154.4	151.6
	2500	413.7	400.9	351.6	320.8	297.2	278.1	263.5	257.4	252.7

Material Group	Pressure Class	Maximum Temperature Allowed								
		-29 to 38	50	100	150	200	250	300	325	350
AISI304	150	19	18,3	15,7	14,2	13,2	12,1	10,2	9,3	8,4
	300	49,6	47,8	40,9	37	34,5	32,5	30,9	30,2	29,6
	600	99,3	95,6	81,7	74	69	65	61,8	60,4	59,3
	1500	248,2	239,1	204,3	185	172,4	162,4	154,6	151,1	148,1
	2500	413,7	398,5	340,4	308,4	287,3	270,7	257,6	251,9	246,9

Humidity Limits	0 to 100% RH
Damping Adjustment	User configurable (via digital communication).

Performance Specifications

Reference Conditions	Span starting at zero, temperature of 25°C (77°F), atmospheric pressure, power supply of 24 Vdc, silicone oil fill fluid, isolating diaphragms in 316L SST and digital trim equal to lower and upper range values.
Accuracy	<p>For differential and gage transmitters, ranges 1, 2, 3, 4, 5 and 6: 0.1 URL ≤ span ≤ URL: ± 0.075% of span 0.025 URL ≤ span < 0.1 URL: ± [0.0375 + 0.00375 URL/span]% of span 0.0085 URL ≤ span < 0.025 URL: ± [0.0015+0.00465 URL/span]% of span</p> <p>For absolute transmitters ranges 2, 3, 4, 5 and 6, diaphragms in Tantalum or Monel or fill fluid in Fluorolube: 0.1 URL ≤ span ≤ URL: ± 0.1% of span 0.025 URL ≤ span < 0.1 URL: ± [0.05 + 0.005 URL/span]% of span 0.0085 URL ≤ span < 0.025 URL: ± [0.01 + 0.006 URL/span]% of span</p> <p>For differential and gage transmitter range 0, diaphragms in 316L SST and fill fluid in Silicone or Halocarbon: 0.2 URL ≤ span ≤ URL: ± 0.1% of span 0.05 URL ≤ span < 0.2 URL: ± [0.025 + 0.015 URL/span]% of span</p> <p>For Absolute, range 1: 0.2% of span Linearity, hysteresis and repeatability effects are included.</p>

Performance Specifications	
Stability	<p>For ranges 2, 3, 4, 5 and 6: $\pm 0.15\%$ of URL for 5 years at 20 °C temperature change and up to 7 MPa (1000 psi) of static pressure</p> <p>For ranges 0 and 1: $\pm 0.2\%$ of URL for 12 months at 20 °C temperature change and up to 100 kPa (1 bar) of static pressure</p> <p>For level transmitters: $\pm 0.2\%$ of URL for 12 months at 20 °C temperature change</p>
Temperature Effect	<p>For ranges 2, 3, 4, 5 and 6: $0.2 \text{ URL} \leq \text{span} \leq \text{URL}$: $\pm [0.02\% \text{ URL} + 0.06\% \text{ span}]$ per 20 °C (68 °F) $0.0085 \text{ URL} \leq \text{span} < 0.2 \text{ URL}$: $\pm [0.023\% \text{ URL} + 0.045\% \text{ span}]$ per 20 °C (68 °F)</p> <p>For range 1: $0.2 \text{ URL} \leq \text{span} \leq \text{URL}$: $\pm [0.08\% \text{ URL} + 0.05\% \text{ span}]$ per 20 °C (68 °F) $0.025 \text{ URL} \leq \text{span} < 0.2 \text{ URL}$: $\pm [0.06\% \text{ URL} + 0.15\% \text{ span}]$ per 20 °C (68 °F)</p> <p>For range 0: $0.2 \text{ URL} \leq \text{span} \leq \text{URL}$: $\pm [0.15\% \text{ URL} + 0.05\% \text{ span}]$ per 20 °C (68 °F) $0.05 \text{ URL} \leq \text{span} < 0.2 \text{ URL}$: $\pm [0.1\% \text{ URL} + 0.3\% \text{ span}]$ per 20 °C (68 °F)</p> <p>For LD302L: 6 mmH₂O per 20 °C for 4" and DN100 17 mmH₂O per 20 °C for 3" and DN80 Consult for other flange dimensions and fill fluid.</p>
Static Pressure Effect	<p>Zero error: For ranges 2, 3, 4, 5 and 6: $\pm 0.033\%$ URL per 7MPa (1000 psi) For range 1: $\pm 0.05\%$ URL per 1.7 MPa (250 psi) For range 0: $\pm 0.1\%$ URL per 0.5 MPa (5 bar) For level transmitters: $\pm 0.1\%$ URL per 3.5 MPa (500 psi) The zero error is a systematic error that can be eliminated by calibrating at the operating static pressure.</p> <p>Span error: For ranges 2, 3, 4, 5 and 6: correctable to $\pm 0.2\%$ of reading per 7MPa (1000 psi) For range 1 and level transmitters: correctable to $\pm 0.2\%$ of reading per 3.5 MPa (500 psi) For range 0: correctable to $\pm 0.2\%$ of reading per 0.5 MPa (5 bar)</p>
Power Supply Effect	$\pm 0.005\%$ of calibrated span per volt
Mounting Position Effect	Zero shift of up to 250 Pa (1 inH ₂ O) which can be calibrated out. No span effect.
Electromagnetic Interference Effect	Approved according to IEC61326-1:2006, IEC61326-2-3:2006, IEC61000-6-4:2006, IEC61000-6-2:2005.

NOTES

URL = Lower Range Limit. LRL = Upper Range Limit.

Physical Specifications	
Electrical Connection	<p>1/2 - 14 NPT M20 X 1.5 PG 13.5 DIN 3/4 - 14 NPT (with 316 SST adapter for 1/2 - 14 NPT) 3/4 - 14 BSP (with 316 SST adapter for 1/2 - 14 NPT) 1/2 - 14 BSP (with 316 SST adapter for 1/2 - 14 NPT)</p> <p>Note: Explosion Proof approvals do not apply to adapter, only to Transmitter</p>
Process Connection	<p>1/4 - 18 NPT or 1/2 -14 NPT (with adapter) For L models see Ordering Code. See Ordering Code for more options.</p>
Wetted Parts	<p>Isolating Diaphragms: 316L SST, Hastelloy C276, Monel 400 or Tantalum</p> <p>Drain/Vent Valves and Plug: 316 SST, Hastelloy C276 or Monel 400</p> <p>Flanges: Plated Carbon Steel, 316 SST-CF8M (ASTM - A351), Hastelloy C276-CW-12MW (ASTM - A494) or Monel 400</p> <p>Wetted O-Rings (For Flanges and Adapters): Buna N, Viton™ or PTFE. Ethylene-Propylene. The LD302 is available in NACE MR-01-75/ISO 15156 compliant materials.</p>
Nonwetted Parts	<p>Electronic Housing: Injected aluminum with polyester painting, epoxy painting or 316 SST - CF8M (ASTM - A351) housing. Complies with NEMA 4X/6P, IP66 or IP66W*, IP68 or IP68W*. *The IP66/68W sealing test (immersion) was performed at 1 bar for 24 hours. For any other situation, please consult Smar. IP66/68W tested for 200h to according NBR 8094 / ASTM B 117 standards.</p>

Nonwetted Parts (continuation)	<p>Blank Flange: When flange adapter and Drain/Vent material is carbon steel, blank flange is in carbon steel, otherwise blank flange is in 316 SST-CF8M (ASTM - A351)</p> <p>Level Flange (LD302L): 316 L SST, 304 SST, Hastelloy C276 and Plated Carbon Steel</p> <p>Fill Fluid: Silicone, Fluorolube, Krytox, Halocarbon 4.2 or Fomblim oils</p> <p>Cover O-Rings: Buna-N</p> <p>Mounting Bracket: Plated carbon steel or 316 SST Accessories (bolts, nuts, washers and U-clamps) in carbon steel or 316 SST</p> <p>Flange Bolts and Nuts: Plated carbon steel, Grade 8 or 316 SST For NACE applications: carbon steel ASTM A193 B7M</p> <p>Identification Plate: 316 SST</p>
Mounting	<p>a) Flange mounted for Level models. b) Optional universal mounting bracket for surface or vertical/horizontal 2"-pipe (DN 50). c) Manifold valve integrated to the transmitter. d) Directly on piping for closely coupled transmitter/orifice flange combinations.</p>
Approximate Weights	<p>3.15 kg (7 lb): all models, except L models. 5.85 to 9.0 kg (13 lb to 20 lb): L models depending on the flanges, extension and materials.</p>
Control Functions Characteristics (Optional)	<p>Function Blocks: RES, TRD, DSP, DIAG, AI, PID, APID, ARTH, INTG, ISEL, CHAR, AALM, TIME, LLAG, OSLD, CT and DENS.</p>

Technical Characteristics of High Performance - CODE L1

High Performance option (code L1) is available under the following conditions only:

Application	Differential and Gage			
Range	D2: -50 to 50 kPa	-200 to 200 inH ₂ O		
	D3: -250 to 250 kPa	-36 to 36 psi		
	D4: -2500 to 2500 kPa	-360 to 360 psi		
	M2: -50 to 50 kPa	-200 to 200 inH ₂ O		
	M3: -100 to 250 kPa	-14.5 to 36 psi		
	M4: -100 to 2500 kPa	-14.5 to 360 psi		
Diaphragm Material	316L SST or Hastelloy C276			
Fill fluid	Silicone			

Performance Specifications	
Reference Conditions	Span starting at zero, temperature of 25 °C (77 °F), atmospheric pressure, power supply of 24 Vdc, silicone oil fill fluid, isolating diaphragms in 316L SST and digital trim equal to lower and upper range values.
Accuracy	<p>RANGE 2: 0.2 URL ≤ span ≤ URL: ± 0.04% of span 0.05 URL ≤ span < 0.2 URL: ± [0.021667 + 0.003667 URL/span]% of span 0.0085 URL ≤ span < 0.05 URL: ± [0.0021 + 0.004645 URL /span]% of span</p> <p>RANGES 3 and 4: 0.1 URL ≤ span ≤ URL: ± 0.05% of span; 0.05 URL ≤ span < 0.1 URL: ± [0.005 + 0.045 URL/span]% of span 0.0085 URL ≤ span < 0.05 URL: ± [0.0021+ 0.004645 URL/span]% of span</p>
Stability	<p>For range 2: ± 0.05% of URL for 6 months For range 3: ± 0.075% of URL for 12 months For range 4: ± 0.1% of URL for 24 months ± 0.2% of URL for 12 years, at 20 °C temperature change and up to 7 MPa (1000 psi) {70 bar} of static pressure, environment free of hydrogen migration.</p>
Temperature Effect	<p>From -10 °C to 50 °C, protected from direct sun radiation: 0.2 URL ≤ span ≤ URL: ± [0.018% URL + 0.012% span] per 20 °C (68 °F) 0.0085 URL ≤ span < 0.2% URL: ± [0.02% URL + 0.002% span] per 20 °C (68 °F)</p>

Static Pressure Effect	Zero error: ± 0.025% URL per 7MPa (1000 psi) The zero error is systematic and can be eliminated by calibrating at the operating static pressure. Span error: Correctable to ± 0.2% of reading per 7 MPa (1000 psi)
-------------------------------	----------------------------------------------------------------------------------------------------------------------------------------------------------------------------------------------------------------------------------------------

Hasteloy is a trademark of the Cabot Corp.
Monel is a trademark of International Nickel Co.
Viton and Teflon are trademarks of E. I. DuPont de Nemours & Co.
Fluorolube is a trademark of Hooker Chemical Corp.

Halocarbon is a trademark of Halocarbon.
Foundation is a trademark of Fieldbus Foundation.
Smart Pressure Transmitters are protected by US patent number 6,433,791

Ordering Code

MODEL DIFFERENTIAL , FLOW, GAGE, ABSOLUTE AND HIGH STATIC PRESSURE TRANSMITTER									
LD302 FOUNDATION™ fieldbus									
COD.	Type	Range Limits		Min. Span	Unit	Range Limits		Min. Span	Unit
		Min.	Max.			Min.	Max.		
D0	Differential and Flow	-1	1	0.05	kPa	-4	4	0,05	inH ₂ O
D1	Differential and Flow	-5	5	0.13	kPa	-20	20	0,13	inH ₂ O
D2	Differential and Flow	-50	50	0.42	kPa	-200	200	0,42	inH ₂ O
D3	Differential and Flow	-250	250	2,08	kPa	-14,7	36	2,08	psi
D4	Differential and Flow	-2500	2500	20,83	kPa	-14,7	360	20,83	psi
M0	Gage	-1	1	0.05	kPa	-4	4	0,05	inH ₂ O
M1	Gage	-5	5	0.13	kPa	-20	20	0,13	inH ₂ O
M2	Gage	-50	50	0.42	kPa	-200	200	0,42	inH ₂ O
M3	Gage	-100	250	2,08	kPa	-14,7	36	2,08	psi
M4	Gage	-100	2500	20,83	kPa	-14,7	360	20,83	psi
M5	Gage	-0.1	25	0.21	MPa	-14,7	3600	0,21	psi
M6	Gage	-0.1	40	0.33	MPa	-14,7	5800	0,33	psi
A1	Absolute	0	5	2.00	kPa	0	20	2,00	inH ₂ O
A2	Absolute	0	50	2.50	kPa	0	200	2,50	inH ₂ O
A3	Absolute	0	250	5.00	kPa	0	36	5,00	psi
A4	Absolute	0	2500	20.83	kPa	0	360	20,83	psi
A5	Absolute	0	25	0.21	Mpa	0	3600	0,21	psi
A6	Absolute	0	40	0.33	MPa	0	5800	0,33	psi
H2	Differential – High Static Pressure	-50	50	0.42	kPa	-200	200	0,42	inH ₂ O
H3	Differential – High Static Pressure	-250	250	2.08	kPa	-14,7	36	2,08	psi
H4	Differential – High Static Pressure	-2500	2500	20.83	kPa	-14,7	360	20,83	psi
H5	Differential – High Static Pressure	-25	25	0.21	MPa	-14,7	3600	0,21	psi

NOTE: The range can be extended up to 0.75 LRL* and 1.2 URL** with small degradation of accuracy.
*LRL = Lower Range Limit.
**URL = Upper Range Limit.

COD. Diaphragm Material and Fill Fluid									
1	316 SST	Silicone Oil (9)	9	316L SST	Fomblim Oil	K	Monel 400	Inert Oil Krytox (1) (3) (15)	
2	316 SST	Inert Oil Fluorolube (2) (15)	A	Monel 400	Fomblim Oil (1) (3)	M	Monel 400 Gold Plated	Silicone Oil (1) (3) (9)	
3	Hastelloy C276	Silicone Oil (1) (9)	D	316L SST	Inert Oil Krytox (3) (15)	P	Monel 400 Gold Plated	Inert Oil Krytox (1) (3) (15)	
4	Hastelloy C276	Inert Oil Fluorolube (1) (2) (15)	E	Hastelloy C276	Inert Oil Krytox (1) (3) (15)	Q	316 SST	Inert Oil Halocarbon 4.2 (2) (3) (15)	
5	Monel 400	Silicone Oil (1) (3) (9)	G	Tantalum	Inert Oil Krytox (3) (15)	R	Hastelloy C276	Inert Oil Halocarbon 4.2 (2) (3) (15)	
7	Tantalum	Silicone Oil (3) (9)	I	316L SST, Gold Plated	Silicone Oil (3) (9)	S	Tantalum	Inert Oil Halocarbon 4.2 (2) (3) (15)	
8	Tantalum	Inert Oil Fluorolube (2) (3) (15)							

COD. Flange(s), Adapter(s) and Drain/Vent Valves Material									
C	Plated CS (Drain/Vent in Stainless Steel) (16)	N	316 SST – CF8M (ASTM A351) (Drain/Vent in Hastelloy C276) (1)	M	Monel 400 (1)				
H	Hastelloy C276 (CW-12MW, ASTM-A494) (1)	O	316 SST – CF8M (Drain/Vent and plug in Monel) Nace Standard						
I	316 SST – CF8M (ASTM A351)	P	316 SST – CF8M (ASTM A351) Flange with PVDF (Kynar) Insert (4) (5) (7) (11)						

COD. Wetted O-Rings Materials									
0	Without O'Rings	K	Kalrez (3)						
B	Buna N	T	Teflon						
E	Ethylene – Propylene (12)	V	Viton						

Note: O-Rings are not available on the sides with remote Seals.

COD. Drain/Vent Position									
O	Without Drain/Vent	D	Bottom						
A	Drain/Vent (Opposite to Process Connection)	U	Top						

Note: For better drain/vent operation, vent valves are strongly recommended. Drain/Vent valve are not available on the sides with remote seals

COD. Local Indicator									
0	Without Indicator	1	With Digital Indicator						

COD. Process Connections									
0	1/4 - 18 NPT (Without Adapter)	B	High Side : 1/2 - 14 NPT and Low Side : Remote Seal (With Plug) (10) (12)						
1	1/2 - 14 NPT With Adapter	D	High Side : Remote Seal (With Plug) and Low Side – 1/2 - 14 NPT (10) (12)						
3	Remote Seal (With Plug) (3) (8)	F	High Side : 1/2 - 14 NPT and Low Side - Remote Seal (Low Volume Flange) (10) (12)						
5	1/2 - 14 NPT Axial with PVDF Insert (5) (7) (14)	H	High Side : Remote Seal (Low Volume Flange) and Low Side -1/2 – 14 NPT (10) (12)						
9	Remote Seal (Low Volume Flange) (3) (4) (8)	Q	8mm hole without thread. According to DIN 19213 (13)						
T	1/2 - 14 BSP (With Adapter)	Z	User's specification						
V	Manifold Valve Integrated to the Transmitter								

COD. Electrical Connections									
0	1/2 - 14 NPT (17)	A	M20 X 1.5 (19)						
1	3/4 - 14 NPT with 316 SST adapter for 1/2 - 14 NPT (18)	B	PG 13.5 DIN (19)						
2	3/4 - 14 BSP with 316 SST adapter for 1/2 - 14 NPT (6)	Z	User's specification						
3	1/2 - 14 BSP with 316 SST adapter for 1/2 - 14 NPT (6)								

COD. Zero Span Adjustment									
1	With Zero and Span Adjustment								

COD. Mounting Bracket for 2" Pipe or Surface Mounting									
0	Without Bracket	7	Carbon steel bracket. Accessories: 316 SST (16)						
1	Carbon steel bracket and accessories (16)	9	L Type, carbon steel bracket. Accessories: 316 SST (16)						
2	316 SST bracket and accessories	A	Flat, 304 SST bracket and 316 SST accessories						
5	L type, carbon steel bracket and accessories (16)	Z	User's specification						
6	L type, 316 SST bracket and accessories								

COD. Continues next page									
--------------------------	--	--	--	--	--	--	--	--	--

LD302 D2 1 I B U 1 0 0 1 2 *

← TYPICAL MODEL NUMBER

Notes	
(1) Meets NACE MR – 01 – 75/ISO 15156 recommendations.	(11) O'Ring should be Viton or Kalrez.
(2) Not available for absolute models nor vacuum applications.	(12) Not available for range 0.
(3) Not available for range 0 and 1.	(13) Only available for pressure transmitters D4 or H4 and 7/16 UNF or M10 x 1.5 flange thread for fixing accessories.
(4) Not recommended for vacuum service.	(14) Only available for flange with PVDF (Kynar) insert.
(5) Maximum pressure 24 bar (350 psi).	(15) Inert Fluid: Safe for oxygen service.
(6) Options not certified for use in hazardous locations.	(16) Not applicable for saline atmosphere.
(7) Drain/Vent not applicable.	(17) Certificate for use in Hazardous Locations (CEPEL, NEPSI, NEMKO, EXAM, FM, CSA).
(8) For remote seal only 316 SST – CF8M (ASTM A351) flange is available (thread 7/16 UNF).	(18) Certificate for use in Hazardous Locations (CEPEL, CSA).
(9) Silicone Oil is not recommended for oxygen (O2) or Chlorine service.	(19) Certificate for use in Hazardous Locations (CEPEL, NEPSI, NEMKO, EXAM).
(10) Only available for differential pressure transmitters.	

LD302		DIFFERENTIAL, FLOW, GAGE, ABSOLUTE AND HING STATIC PRESSURE TRANSMITTERS (CONTINUATION)	
COD.		Flanges Bolts and Nuts Material	
A0	Plated Carbon Steel (Default) (4)	A5	Hastelloy C276
A1	316 SST	A7	Super Duplex Stainless Steel Nace MR0175 / MR0103 Compliant
A2	Carbon Steel (ASTM A193 B7M) (1) (4)		
COD.		Flange thread for fixing accessories (adapters, manifolds, mounting brackets, etc)	
D0	7/16" UNF (Default)	D2	M12 X 1.75
D1	M10 X 1.5		
COD.		Housing Material (6) (7)	
H0	Aluminum (Default) (IP/TYPE)	H3	316 SST for saline atmosphere (IPW/TYPEX) (5)
H1	316 SST – CF8M (ASTM – A351) IP/TYPE	H4	Copperfree Aluminium (IPW/TYPEX) (5)
H2	Aluminium for saline atmosphere (IPW/TYPEX) (5)		
COD.		Tag Plate	
J0	With tag, when specified (Default)		
J1	Blank		
J2	According to user's notes		
COD.		Identification Plate	
I1	FM: XP, IS, NI, DI	I6	Without Certification
I3	CSA: XP, IS, NI, DI	I7	EXAM (DMT): Group I, M1 Ex-ia
I4	EXAM (DMT): Ex-ia	IF	CEPEL: Ex-d
I5	CEPEL: Ex-d, Ex-ia	IE	NEPSI: Ex-ia
COD.		Painting	
P0	Gray Munsell N 6.5 Polyester	P8	Without Painting
P3	Black Polyester	P9	Blue Safety Epoxy – Electrostatic Painting
P4	White Epoxy	PC	Blue Safety Polyesters – Electrostatic Painting
P5	Yellow Polyester		

LD302 - D211 - BU10 - 012 A0 D0 H0 J0 I6 P0 *

← TYPICAL MODEL NUMBER

Optional Items

* Leave blank for no optional items

Burn-out	BD – Down Scale (Accordance to NAMUR NE43 specification). BU – Up Scale (Accordance to NAMUR NE43 specification).
Special Applications	C1 – Degrease Cleaning (Oxygen or Chlorine Service) (3).
High Performance	L1 – 0.04% accuracy (2).
Square Root Extraction	M3 – With Square Root extraction.
Special Features	ZZ – User's specification.

Notes	
(1) Meets NACE MR – 01 – 75/ISO 15156 recommendations.	(5) IP66/68W tested for 200 hours according to NBR 8094 / ASTM B 117 standard.
(2) Only available for differential and gage pressure models.	(6) IPX8 tested in 10 meters of water column for 24 hours.
(3) Degrease cleaning not available for carbon steel flanges.	(7) Ingress Protection:
(4) Not applicable for saline atmosphere.	

Product	CEPEL	NEMKO/EXAM	FM	CSA	NEPSI
LD300	IP66/68W	IP66/68W	Type4X/6(6P)	Type4X	IP67

MODEL										FLANGED PRESSURE TRANSMITTERS									
LD302										FOUNDATION™ fieldbus									
COD.		Range Limits		Min. Span	Unit	Range limits		Min. Span	Unit	Note: The range can be extended up to 0.75 LRL and 1.2 URL with small degradation of accuracy. The upper range value must be limited to the flange rating.									
Min.	Max.	Min.	Max.	Min.	Max.	Min.	Max.												
L2	-50	50	1.25	kPa	-200	200	0.42	inH ₂ O											
L3	-250	250	2.08	kPa	-14.7	36	2.08	psi											
L4	-2500	2500	20.83	kPa	-14.7	360	20.83	psi											
L5	-25000	25000	208.3	kPa	-14.7	3600	0.21	psi											
COD. Diaphragm material and Fill Fluid (Low Side)																			
1	316L SST	Silicone Oil (2)			7	Tantalum	Silicone Oil (2)			E	Hastelloy C276	Inert Oil Krytox (1)(19)			Q	316L SST	Inert Oil Halocarbon 4.2 (19)		
2	316L SST	Inert Oil Fluorolube(3)(19)			8	Tantalum	Inert Oil Fluorolube (3) (19)			G	Tantalum	Inert Oil Krytox (19)			R	Hastelloy C276	Inert Oil Halocarbon 4.2 (1) (19)		
3	Hastelloy C276	Silicone Oil (1) (2)			9	316L SST	Fomblim Oil			K	Monel 400	Inert Oil Krytox (1) (19)			S	Tantalum	Inert Oil Halocarbon 4.2 (19)		
4	Hastelloy C276	Inert Oil Fluorolube (1)(3)(19)			A	Monel 400	Fomblim Oil (1)			M	Monel 400 Gold Plated	Silicone Oil (1) (2)							
5	Monel 400	Silicone Oil (1) (2)			D	316L SST	Inert Oil Krytox (19)			P	Monel 400 Gold Plated	Inert Oil Krytox (1) (19)							
COD. Flange, Adapter and Drain/Vent Valves material (Low Side)																			
A	304L SST									M	Monel 400 (1)								
C	Plated CS (Drain/Vent in Stainless Steel) (20)									N	316 SST – CF8M (ASTM – A351) (Drain/Vent in Hastelloy C276) (1)								
H	Hastelloy C276 (CW – 12MW, ASTM – A494) (1)									P	316 SST – CF8M (ASTM – A351) Flange with PVDF (Kynar) insert (3) (4) (5)								
I	316 SST – CF8M (ASTM – A351)																		
COD. Wetted O'Ring Material (Low Side)																			
0	Without O'Rings				K	Kalrez						Note: O'rings are not available on the sides with remote seals.							
B	Buna-N				T	Teflon													
E	Ethylene - Propylene				V	Viton													
COD. Drain/Vent Position (Low Side)																			
0	Without Drain/Vent									D	Bottom								
A	Drain/Vent (Opposite to Process Connection)									U	Top								
COD. Local Indicator																			
0	Without Indicator									1	With Digital indicator								
COD. Process Connection (Low Side)																			
0	1/4 - 18 NPT (Without Adapter)									T	1/2 14 BSP (With Adapter)								
1	1/2 - 14 NPT (With Adapter)									U	Low Volume Flange For Level Welded								
3	Remote Seal (With Plug) (7)									V	Without Connection (Mounting With Gage Flange)								
5	1/2 - 14 NPT Axial with PVDF Insert (3) (4) (6)									W	Without Connection (Absolut Reference)								
9	Remote Seal (Low Volume Flange) (3) (7)																		
COD. Electrical Connection																			
0	1/2 - 14 NPT (25)									A	M20 x 1.5 (26)								
1	3/4 - 14 NPT (with 316 SST adapter for 1/2 - 14 NPT) (22)									B	PG 13.5 DIN (26)								
2	3/4 - 14 BSP (with 316 SST adapter for 1/2 - 14 NPT) (9)									Z	User's specification								
3	1/2 - 14BSP (with 316 SST adapter for 1/2 - 14 NPT) (9)																		
COD. Zero and Span Adjust																			
1	With Zero and Span Adjustment																		
COD. Process Connection																			
U	1" 150 # (ANSI B16.5) (29)			C	3" 600 # (ANSI B16.5)			S	JIS 40A 20K (23)										
V	1" 300 # (ANSI B16.5) (29)			N	3" 600 # (ANSI B16.5 RTJ)			F	JIS 50A 10K (23)										
W	1" 600 # (ANSI B16.5) (29)			3	4" 150 # (ANSI B16.5)			T	JIS 50A 40K (23)										
O	1.1/2" 150 # (ANSI B16.5)			4	4" 300 # (ANSI B16.5)			K	JIS 50A 20K (23)										
P	1.1/2" 300 # (ANSI B16.5)			D	4" 600 # (ANSI B16.5)			G	JIS 80A 10K (23)										
Q	1.1/2" 600 # (ANSI B16.5)			5	DN 25 PN 10/40 (29)			L	JIS 80A 20K (23)										
9	2" 150 # (ANSI B16.5)			R	DN 40 PN 10/40			H	JIS 100A 10K (23)										
A	2" 300 # (ANSI B16.5)			E	DN 50 PN 10/40			M	JIS 100A 10K (23)										
B	2" 600 # (ANSI B16.5)			6	DN 80 PN 10/40			Z	User's specification										
1	3" 150 # (ANSI B16.5)			7	DN 100 PN 10/16														
2	3" 300 # (ANSI B16.5)			8	DN 100 PN 25/40														
COD. Type and Flange Material (Level Tap)																			
2	316L SST (Integral Flange)			4	304 SST (Slip-on Flange)			6	Carbon Steel (Slip-on Flange)										
3	Hastelloy C276 (Integral Flange)			5	316 SST (Slip-on Flange)			Z	User's specification										
COD. Extension Length																			
0	0 mm (0")			3	150 mm (6")			Note: Extension Material 316L SST											
1	50 mm (2")			4	200 mm (8")														
2	100 mm (4")			Z	User's specification														
COD. Diaphragm Material / Extension (Level Tap)																			
A	304L SST / 304L SST			6	316L SST with Teflon Lining (For 2" and 3")														
1	316L SST / 316 SST			7	316L SST Gold plated														
2	Hastelloy C276 / 316 SST			B	Tantalum with Teflon Lining														
3	Monel 400 / 316 SST			L	316L SST Halar Plated (18)														
4	Tantalum / 316 SST (10)			C	Hastelloy Teflon Plated														
5	Titanium / 316 SST (10)																		
COD. Fill Fluid																			
1	DC – 200/20 Silicone Oil			G	Glycerin (6)														
3	DC704 Silicone Oil			B	Fomblim 06/06														
2	MO – 10 Fluorolube Oil (8)			H	Halocarbon 4.2														
4	Krytox Oil			T	Syltherm 800 Oil														
N	Neobee M20 Propylene Glycol Oil																		
COD. Housing Material																			
0	Without Gaskets (12)									3	Super Duplex (UNS 32750) (11)								
1	316 SST									4	Duplex (UNS 31803) (11)								
2	Hastelloy C276									5	Stainless Steel 304L (11)								
COD. Gasket Material																			
0	Without gasket									C	Copper								
T	Teflon (PTFE)									I	316 L SST								
G	Grafoil (Flexible lead)																		
COD. Continues Next Page																			

LD302 L2 1 1 I B U 1 1 0 0 1 1 2 2 1 1 1 1 T *

← TYPICAL MODEL NUMBER

LD302		FLANGED PRESSURE TRANSMITTERS (CONTINUATION)					
COD. Flanges Bolts and Nuts Material		A0 Plated Carbon Steel (Default) (20)		A2 Carbon Steel (ASTM A193 B7M) (1) (20)		A5 Hastelloy C276	
COD. Flange Thread for Fixing Accessories (Adapters, Manifolds, Mounting Brackets, etc)		D0 7/16" UNF (Default)		D1 M10 X 1.5 Thread		D2 M12 X 1.75	
COD. Flange Facing Finish (16)		Q0 Raised Face – RF (Default)		Q2 Ring Joint Face – RTJ (Only available for ANSI standard flange) (15)		Q4 Grooved Face (11)	
COD. Housing Material (27) (28)		H0 Aluminum (Default) (IP/TYPE)		H1 316 SST – CF8M ASTM – A351 (IP/TYPE)		H3 316 SST (IPW/TYPEX) (21)	
		H2 Aluminium (IPW/TYPEX) (21)				H4 Copperfree Aluminium (IPW/TYPEX) (21)	
COD. Tag Plate		J0 With tag, when specified (Default)		J1 Blank		J2 According to user's notes	
COD. Identification Plate		I1 FM: XP, IS, NI, DI		I5 CEPEL: Ex-d, Ex-ia		IF CEPEL: Ex-d	
		I3 CSA: XP, IS, NI, DI		I6 Without Certification		IM BDSR-GOST: Ex-d, Ex-ia	
		I4 EXAM (DMT): Ex-ia		I7 EXAM (DMT): Group I, M1 Ex-ia			
COD. Painting		P0 Gray Munsell N6,5 Polyesters		P8 Without Painting			
		P3 Black Polyester		P9 Blue Safety Epoxy – Electrostatic Painting			
		P4 White Epoxy		PC Blue Safety Polyesters – Electrostatic Painting			
		P5 Yellow Polyester					

LD302-L2L-BU10-01-12211 A0 D0 Q0 H0 J0 I6 P0 * ← TYPICAL MODEL NUMBER

Optional Items

* Leave blank for no optional items

Burn-out	BD - Down Scale (Accordance to NAMUR NE43 specification)	BU - Up Scale (Accordance to NAMUR NE43 specification).
Special Applications	C1 - Degrease Cleaning (Oxygen or Chlorine Service) (13)	C2 - For vacuum application.
Special Features	ZZ - User's specification.	
Gasket Connection	U0 - With one Flush Connection 1/4" NPT (if supplied with gasket) U1 - With two Flush Connections 1/4" NPT per 180 °C U2 - With two Flush Connections 1/4" NPT per 90 °C U3 - With two Flush Connections 1/2" NPT - 14 NPT per 180 °C (with cover) U4 - Without Gasket Connection	
Isolator Kit (14)	K0 - Without Kit	K1 - With Kit
Diaphragm Thickness	N0 – Default (24)	N1 - 0.1mm (11)

NOTES

- (1) Meets NACE MR – 01 – 75/ISO 15156 recommendations.
- (2) Silicone Oils not recommendations for Oxygen (O₂) or Chlorine service.
- (3) Not applicable for vacuum service.
- (4) Drain/Vent not applicable.
- (5) O'Ring should be Viton or Kalrez.
- (6) Maximum pressure 24 bar.
- (7) For remote Seal only 316 SST - CF8M (ASTM A3510 flange is available (thread M12).
- (8) Fluorolube fill fluid is not available for Monel diaphragm.
- (9) Options not certified for use in hazardous locations.
- (10) Attention, check corrosion rate for the process, tantalum plate 0.1 mm, AISI 316L extension 3 to 6mm.
- (11) Item by inquiry.
- (12) Supplied without Gasket.
- (13) Degreaser's cleaning is not available for carbon steel flanges
- (14) The insulator kit is applicable with Raised Face (HO) and Smooth Face (H1) with Gasket material.
T (Teflon) and only for the following models:
- For models with extension the Gasket T (Teflon) it has special share.
- (15) Gasket for housing, available only in Stainless 316.
- (16) Finishing flange faces:
ANSI B 16.5 / MSS-SP6:
- Raised or Smoth Face with gooved lining: 3.2 to 6.3 µm Ra (125 a 250 µ" AA);
Small or Large Tongue Face and Small or Large Groove with smooth finishing
not exceeding: 3.2 µm Rt (125 µ" AA);
RTJ ANSI B 16.20 / MSS-SP6:
- Smooth finishing not exceeding: 1.6 µm Rt (63 µ" AA);
DIN EN-1092-1:
- Grooved finishing "B1" (PN 10 a PN40): 3.2 a 12.5 µm Ra (125 a 500 µ" AA);
Smooth finishing "B2" (PN 63 a PN100), "C" (Tongue) e "D" (Groove): 0.8 a 3.2 µm Ra (32 a 125 µ" AA).

- DIN 2501 (DIN 2526):
- Smooth finishing "E" (PN 160 a PN250): Rz = 16 (3.2 µm Ra (125 µ" AA).
Standard JIS B2201
Grooved finishing 3.2 a 6.3 µm Ra (125 a 250 µ" AA).
- (17) Range of application of temperature from -40 °C to 150 °C.
- (18) Applicable only to:
- Thickness of steel: 0.05 mm
- Diameter/capillary length:
2" ANSI B 16.5 DN 50 DIN, JIS 50 A, for seals up to 3 meters of capillary and level models (by inquiry).
3" ANSI B 16.5 DN 80 DIN, JIS 80 A, for seals up to 5 meters of capillary and level models.
- Faces: RF and FF;
- Temperature Range: +10 °C to 100 °C
+ 101 to 150 °C (by inquiry)
- Not applicable for diaphragm thickness;
- Not applicable for use with gaskets.
- (19) Inert Fluid: Oxygen Compatibility, safe for oxygen service.
- (20) Not applicable for saline atmosphere.
- (21) IP66/68W tested for 200 hours according to NBR 8094 / ASTM B 117 standard.
- (22) Certificate for use in Hazardous Locations (CEPEL, CSA).
- (23) Not available for slip-on flange.
- (24) Diaphragms of Titanium and Monel available only in 0.1 mm, and diaphragms of Tantalum only in 0.075 mm.
- (25) Certificate for use in Hazardous Locations (CEPEL, NEPSI, NEMKO, EXAM, FM, CSA).
- (26) Certificate for use in Hazardous Locations (CEPEL, NEPSI, NEMKO, EXAM).
- (27) IPX8 tested in 10 meters of water column for 24 hours.
- (28) Ingress Protection:

Product	CEPEL	NEMKO/EXAM	FM	CSA	NEPSI
LD300	IP66/68W	IP66/68W	Type4X/6(6P)	Type4X	IP67

(29) Not available for integral flange.

MODEL	SANITARY PRESSURE TRANSMITTERS											
LD302	FOUNDATION™ fieldbus											
CODE	Range Limits		Min. Span	Unit	Range Limits		Min. Span	Unit				
	Min.	Max.			Min.	Max.						
S2	-50	50	1.25	kPa	-200	200	0.42	inH ₂ O	Note: The range can be extended up to 0.75 LRL and 1.2 URL with small degradation of accuracy. The upper range value must be limited to the connection.			
S3	-250	250	2.08	kPa	-14.7	36	2.08	psi				
S4	-2500	2500	20.83	kPa	-14.7	360	20.83	psi				
S5	-25000	25000	208.30	kPa	-14.7	3600	0.21	psi				
COD Diaphragm Material and Fill Fluid (Low Side)												
1	316L SST	Silicone Oil (2)	7	Tantalum	Silicone Oil (2)	E	Hastelloy C276	Inert Krytox Oil (1) (17)	Q	316L SST	Inert Haloc 4.2 Oil (17)	
2	316L SST	Inert Fluorolube Oil (3) (17)	8	Tantalum	Inert Fluorolube Oil (3) (17)	G	Tantalum	Inert Krytox Oil (17)	R	Hastelloy C276	Inert Haloc 4.2 Oil (1) (17)	
3	Hastelloy C276	Silicone Oil (1) (2)	9	316L SST	Fomblin Oil	K	Monel 400	Inert Krytox Oil (1) (17)	S	Tantalum	Inert Haloc 4.2 Oil (17)	
4	Hastelloy C276	Inert Fluorolube Oil (1) (3) (17)	A	Monel 400	Fomblin Oil (1)	M	Monel 400 Gold Plated	Silicone Oil (1) (2)				
5	Monel 400	Silicone Oil (1) (2)	D	316L SST	Inert Krytox Oil (17)	P	Monel 400 Gold Plated	Inert Krytox Oil (1) (17)				
CODE Flange(s), Adapter (s) and Drain Valve(s) Material (Low Side)												
C	Plated CS (Drain in Stainless Steel) (15)						M	Monel 400 (1)				
H	Hastelloy C276 (CW-12MW, ASTM - A494) (1)						N	316 SST – CF8M (ASTM – A351) (Drain in Hastelloy C276) (1)				
I	316 SST - CF8M (ASTM - A351)						P	316 SST – CF8M (ASTM – A351) Flange with PVDF (Kynar) insert (3) (4) (5)				
CODE Wetted O-Ring Material (Low Side)												
0	Without O-Ring		E	Ethylene - Propylene		T	Teflon		Note: O-Rings are not available on the sides with remote seal.			
B	Buna-N		K	Kalrez		V	Viton					
CODE Drain Position (Low Side)												
0	Without Drain						D	Bottom		Note: For better drain operation, drain valves are strongly recommended. Drain valve are not available on the sides with remote seal.		
A	Drain (Opposite to process connection)						U	Top				
CODE Local Indicator												
0	Without Indicator						1	With Digital Indicator				
CODE Process Connection (Low Side)												
0	1/4 - 18 NPT (Without Adapter)						T	1/2-14 BSP (With Adapter)				
1	1/2 - 14 NPT (With Adapter)						U	Low Volume Flange For Level Welded				
3	Remote Seal (With Plug – Vacuum Assembly) (7)						V	Without Connection (Mounting With Gage Flange)				
5	1/2 - 14 NPT Axial with PVDF insert (3) (4) (6)						W	Without Connection (Absolute Reference)				
9	Remote Seal (Low Volume Flange) (3) (7)											
CODE Electrical Connection												
0	1/2 - 14 NPT (18)						A	M20 X 1.5 (20)				
1	3/4 - 14 NPT (With 316 SST adapter for 1/2 - 14 NPT) (19)						B	PG 13.5 DIN (20)				
2	3/4 - 14 BSP (With 316 SST adapter for 1/2 - 14 NPT) (9)						Z	User's Specification				
3	1/2 - 14 BSP (With 316 SST adapter for 1/2 - 14 NPT) (9)											
CODE Zero and Span Adjust												
1	With Local Adjustment											
CODE Process Connection												
8	Threaded DN25 DIN 11851 – with extension / 316L SST (10) (11)						7	Threaded SMS 2" - with extension / 316L SST (10) (11)				
9	Threaded DN40 DIN 11851 - with extension / 316L SST (10) (11)						E	Threaded SMS 2" - without extension / 316L SST (10) (11)				
H	Threaded DN40 DIN 11851 – without extension / 316L SST (10)						M	Threaded SMS 3" - with extension / 316L SST (10) (11)				
V	Threaded DN50 DIN 11851 - with extension / 316L SST (10) (11)						F	Threaded SMS 3" - without extension / 316L SST (10) (11)				
U	Threaded DN50 DIN 11851 - without extension / 316L SST (10)						1	Threaded SMS 3" HP (High Pressure) - without extension / 316L SST (11)				
X	Threaded DN80 DIN 11851 - with extension / 316L SST (10) (11)						6	Tri-Clamp 2" - with extension / 316L SST (11)				
W	Threaded DN80 DIN 11851 - without extension / 316L SST (10)						D	Tri-Clamp 2" – without extension / 316L SST (11)				
4	Threaded IDF 2" - with extension / 316L SST (10) (11)						N	Tri-Clamp 2" HP (High Pressure) - with extension / 316L SST (8) (11)				
B	Threaded IDF 2" – without extension / 316L SST (10) (11)						P	Tri-Clamp 2" HP (High Pressure) – without extension / 316L SST (8) (11)				
K	Threaded IDF 3" - with extension / 316L SST (10) (11)						I	Tri-Clamp 3" - with extension / 316L SST (11)				
3	Threaded IDF 3" - without extension / 316L SST (10) (11)						G	Tri-Clamp 3" – without extension / 316L SST (11)				
5	Threaded RJT 2" - with extension / 316L SST (10) (11)						J	Tri-Clamp 3" HP (High Pressure) - with extension / 316L SST (8) (11)				
C	Threaded RJT 2" - without extension / 316L SST (10)						R	Tri-Clamp 3" HP (High Pressure) – without extension / 316L SST (8) (11)				
L	Threaded RJT 3" - with extension / 316L SST (10) (11)						Z	User's specification				
2	Threaded RTJ 3" - without extension / 316L SST (10)											
S	Threaded SMS 1 1/2" – without extension / 316L SST (10) (11)											
CODE Diaphragm Material												
H	Hastelloy C276						I	316L SST				
CODE Fill Fluid												
S	DC 200 – Silicone Oil						T	Syltherm 800		B	Fomblin 06/06	
D	DC 704 – Silicone Oil						N	Neobee M20 (11)		K	Krytox 1506	
F	Fluorolube MO-10						G	Glycerin + Water (12)		H	Halocarbom 4.2	
CODE Wet O-ring												
0	Without O-ring		T	Teflon (11)		B	Buna-N (11)		V	Viton (11)		
CODE Tank Adapter												
0	Without Tank Adapter						1	With Tank Adapter in 316 SST				
CODE Tri-Clamp												
0	Without Tri-Clamp											
2	With Tri-Clamp in 304 SST											

LD302 S2 1 I B U 1 0 0 1 A I S T 1 2 *

← TYPICAL MODEL NUMBER

* Leave it blank when there are not optional items.

LD302	SANITARY PRESSURE TRANSMITTERS (CONTINUATION)					
CODE	Flange Bolts and Nuts Material					
A0	Plated Carbon Steel (Default) (15)			A2	Carbon Steel (ASTM A193 B7M) (1) (15)	
A1	316 SST			A5	Hastelloy C276	
CODE	Flange Thread for Fixing Accessories (Adapters, Manifolds, Mounting Brackets, etc)					
D0	7/16" UNF (Default)			D2	M12 X 1.75	
D1	M10 X 1.5 Thread					
CODE	Housing Material (21) (22)					
H0	Aluminum (Default) (IP/TYPE)			H3	316 SST for Saline Atmosphere (IPW/TYPEX) (16)	
H1	316 SST – CF8M (ASTM – A351) (IP/TYPE)			H4	Copper Free Aluminium (IPW/TYPEX) (16)	
H2	Aluminum for Saline Atmosphere (IPW/TYPEX) (16)					
CODE	TAG Plate					
J0	With tag, when specified (Default)			J1	Blank	
J2				According to user's notes		
CODE	Identification Plate					
I1	FM: XP, IS, NI, DI			I6	Without Certification	
I3	CSA: XP, IS, NI, DI			I7	EXAM (DMT): Class I, M1 Ex-ia	
I4	EXAM (DMT): Ex-ia			IF	CEPEL: Ex-d	
I5	CEPEL: Ex-d, Ex-ia					
CODE	Painting					
P0	Gray Munsell N 6.5 Polyester			P8	Without Painting	
P3	Black Polyester			P9	Safety Blue Epoxy – Electrostatic Painting	
P4	White Epoxy			PC	Safety Polyester - Electrostatic Painting	
P5	Yellow Polyester					

LD302-S211- BU10-01A2- IST12	A0	D0	H0	J0	I6	P0	*
------------------------------------	----	----	----	----	----	----	---

← TYPICAL MODEL NUMBER

* Leave it blank when there are not optional items.

Optional Items

Burn-out	BD - Down Scale (Accordance to NAMUR NE43 specification) BU - Up Scale (Accordance to NAMUR NE43 specification)
Special Procedures	C1 - Degrease Cleaning (Oxygen or Chlorine Service) (13) C2 - For Vacuum Application C4 - Polishing of the wet parts according to 3A Certification (11) (12)
Special Features	ZZ - User's Specification
Diaphragm Thickness	N0 – Default N1 - 0.1mm (12)

Note													
<p>(1) Meets NACE MR-01-75/ISO 15156 recommendations.</p> <p>(2) Silicone oil not recommended for Oxygen (O2) or Chlorine Service.</p> <p>(3) Not applicable for vacuum service.</p> <p>(4) Drain not applicable.</p> <p>(5) O-Ring material must be of Viton or Kalrez.</p> <p>(6) Maximum pressure 24 bar.</p> <p>(7) For remote seal is only available flange in 316 Stainless Steel - CF8M (ASTM A351) (thread M12).</p> <p>(8) HP – High Pressure.</p> <p>(9) Options not certified for use in hazardous locations.</p> <p>(10) Not available for Tri-clamp.</p> <p>(11) Compliant with 3A-7403 standard for food and other applications where sanitary connections are required: - Neobee M2O Fill Fluid - Finishing wet Face: 0.8 µm Ra (32 µ" AA) - Wet O-Ring: Viton, Buna-N and Teflon</p>	<p>(12) Item by inquiry.</p> <p>(13) Degrease cleaning is not available for Carbon Steel Flanges.</p> <p>(14) Temperature application range: -40 to 140 °C.</p> <p>(15) Not applicable for saline atmosphere.</p> <p>(16) IP66/68W tested for 200 hours according to NBR 8094 / ASTM B 117 standard.</p> <p>(17) The inert fluid guarantees safety for Oxygen (O₂) service.</p> <p>(18) Certificate for use in Hazardous Locations (CEPEL, NEPSI, NEMKO, EXAM, FM, CSA).</p> <p>(19) Certificate for use in Hazardous Locations (CEPEL, CSA).</p> <p>(20) Certificate for use in Hazardous Locations (CEPEL, NEPSI, NEMKO, EXAM).</p> <p>(21) IPX8 tested in 10 meters of water column for 24 hours.</p> <p>(22) Ingress Protection:</p> <table border="1"> <thead> <tr> <th>Product</th> <th>CEPEL</th> <th>NEMKO/EXAM</th> <th>FM</th> <th>CSA</th> <th>NEPSI</th> </tr> </thead> <tbody> <tr> <td>LD300</td> <td>IP66/68W</td> <td>IP66/68W</td> <td>Type4X/6(6P)</td> <td>Type4X</td> <td>IP67</td> </tr> </tbody> </table>	Product	CEPEL	NEMKO/EXAM	FM	CSA	NEPSI	LD300	IP66/68W	IP66/68W	Type4X/6(6P)	Type4X	IP67
Product	CEPEL	NEMKO/EXAM	FM	CSA	NEPSI								
LD300	IP66/68W	IP66/68W	Type4X/6(6P)	Type4X	IP67								

CERTIFICATIONS INFORMATION

European Directive Information

Authorized representative in European Community
Smar Gmbh-Rheingaustrasse 9-55545 Bad Kreuznach

PED Directive (97/23/EC) – Pressure Equipment Directive

This product is in compliance with the directive and it was designed and manufactured in accordance with sound engineering practice using several standards from ANSI, ASTM, DIN and JIS.

EMC Directive (2004/108/EC) - Eletromagnetic Compatibility

The EMC test was performed according to IEC standard: IEC61326-1:2006, IEC61326-2-3:2006, IEC61000-6-4:2006, IEC61000-6-2:2005. For use in environment only.
Keep the shield insulated at the instrument side, connecting the other one to the ground if necessary to use shielded cable.

ATEX Directive (94/9/EC) – Equipment and protective systems intended for use in potentially explosive atmospheres

This product was certified according European Standards at NEMKO and EXAM (old DMT). The certified body for manufacturing quality assessment is EXAM (number 0158).

LVD Directive 2006/95/EC – Electrical Equipment designed for use within certain voltage limits

According the LVD directive Annex II the equipment under ATEX "Electrical equipment for use in an explosive atmosphere" directive are excluded from scope from this directive.

Other Approval

Sanitary Approval

Certifier Body: 3A Sanitary Standards

Model Designations: **LD302** with or without extension
Sensors and Sensor Fittings and Connections Used on Fluid Milk and Milk Products,
Number: 74-03. (Authorization No. 873).

Device Registration ITK:

Certifier Body: Fieldbus Foundation

Model: **LD302**
Device Type: Pressure Transmitter
ITK Ver: 4.60
ITK Campaign No.: IT040600
Registration Date: 6/26/2007
DD Revisions: 0x04
CFF Revisions: 040102.cff

The above device has successfully completed rigorous testing by the Fieldbus Foundation and has received registration and the right to use the FF checkmark logo as specified by MT-045.

Hazardous Locations Certifications

NOTE

The IP68 sealing test (immersion) was performed at 1 bar for 24 hours. For any other situation, please consult Smar.

North American Certifications

FM Approvals (Factory Mutual)

Certificate N: FM 4Y3A4.AX and 3015629

Explosion-proof for Class I, Division 1, Groups A, B, C and D.

Dust-ignition proof for Class II, Division 1, Groups E, F and G; Class III, Division 1.

Intrinsically Safe for use in Class I, Division 1, Groups A, B, C and D; Class II, Division 1, Groups E, F and G; Class III, Division 1. FISCO Field Device Ex ia IIC T4.

Non-incendive for Class I, Division 2, Groups A, B, C and D. FNICO Field Device Ex n1 IIC T5.

Entity parameters: $V_{max} = 24 \text{ Vdc}$ $I_{max} = 250 \text{ mA}$ $P_i = 5.32 \text{ W}$ $C_i = 5 \text{ nF}$ $L_i = 8 \text{ Mh}$

Maximum Ambient Temperature: 60 °C.

Enclosure Type 4X/6/6P or Type 4/6/6P.

Canadian Standards Association (CSA)

Certificate N: CSA1111005

Class 2258 02 Explosion Proof for Class I, Division 1, Groups B, C and D; Class II, Division 1, Groups E, F and G; Class III, Division 1; Class I, Division 2, Groups A, B, C and D; Class II, Division 2, Groups E, F and G; Class III. FNICO Field Device Ex n1 IIC T5.

Class 2258 04 Intrinsically Safe, Entity – For Hazardous Locations for Class I, Division 1, Groups A, B, C and D; Class II, Division 1, Groups E, F and G; Class III, Division 1. FISCO Field Device Ex ia IIC T4.

• Intrinsically safe with entity parameters: $V_{max} = 24 \text{ V}$ $I_{max} = 380 \text{ mA}$ $P_i = 5.32 \text{ W}$ $C_i = 5 \text{ nF}$ $L_i = 10 \text{ uH}$.

Maximum Ambient Temperature: 40 °C.

Enclosure Type 4X or Type 4.

European Certifications

Certificate No: NEMKO 13 ATEX 1574X

Explosion Proof: Group II, Category 2 G, Ex d, Group IIC, Temperature Class T6, EPL Gb

Ambient Temperature: -20 to 60 °C

Certificate No: NEMKO 13 ATEX 1574X

Environmental Protection: IP66W/68W

Special Conditions for Safe Use

Repairs of the flameproof joints must be made in compliance with the structural specifications provided by the manufacturer. Repairs must not be made on the basis of values specified in tables 1 and 2 of EN/IEC 60079-1.

The Essential Health and Safety Requirements are assured by compliance with:

EN 60079-0:2012 General Requirements

EN 60079-1:2007 Flameproof Enclosures “d”

Certificate No: DMT 00 ATEX E 067

ATEX Intrinsically Safe

Group II 1/2G Ex ia IIC T4/T5/T6

Entity parameters: $P_i = 5.32 \text{ W}$ $U_i = 24 \text{ V}$ $I_i = 380 \text{ mA}$ $C_i \leq 5 \text{ nF}$ $L_i = \text{neg}$.

Ambient Temperature: $-40 \text{ °C} \leq T_a \leq 60 \text{ °C}$

FISCO Field Device Ex ia IIC T4

FNICO Field Device Ex nL IIC T4

South America Certification

Certificado No: CEPPEL-EX-075/96

Intrinsicamente Seguro – Ex-ia IIC T4/T5

Parâmetros: $P_i = 5.32 \text{ W}$ $U_i = 30 \text{ V}$ $I_i = 380 \text{ mA}$ $C_i = 5 \text{ nF}$ $L_i = \text{Neg}$

Temperatura ambiente: $-20 < T_{amb} < 65 \text{ °C}$ para T4;

$-20 < T_{amb} < 50 \text{ °C}$ para T5.

FISCO Field Device Ex ia IIC T4

FNICO Field Device Ex n1 IIC T5

Certificado No: CEPEL-EX-54/98
 À prova de explosão – Ex-d IIC T6
 Temperatura ambiente: 40 °C
 Grau de Proteção: IP 66/68 ou IP66/68W
Asia Certification

Certificate No: Nepsi GYJ04140
 Intrinsically safe - Ex ia IIC T4/T5/T6
 Entity Parameters: Pi = 2.0 W Ui = 16 V li = 250 mA Ci = 5 nF Li = 0

FISCO Field Device Ex ia IIC T4

Identification Plate and Control Drawing

Identification Plate

- Identification of Intrinsically safe and Explosion Proof for gas and steam:

FM



CSA



NEMKO and EXAM

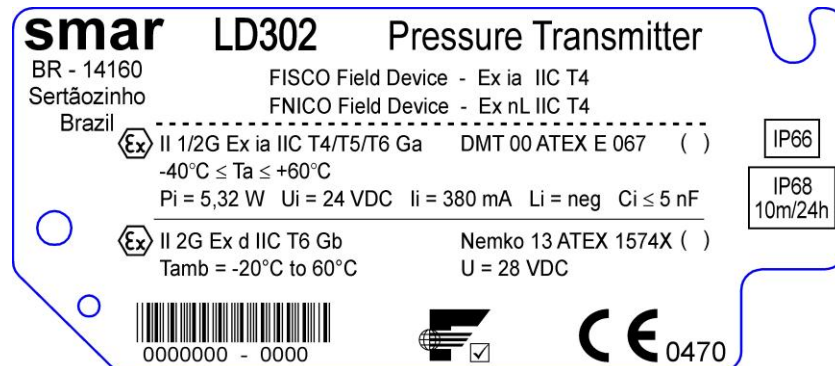

CEPEL

smar LD302 Transmissor de Pressão
BR - 14160

Segurança
 
INMETRO OCP 0007

FISCO Field Device - Ex ia IIC T4
FNICO Field Device - Ex nL IIC T4

BR - Ex d IIC T6 CEPEL - EX - 054/98
BR - Ex ia IIC T4/T5 CEPEL - EX - 075/96

Tamb = -20° a 65°C (T4) -20° a 50°C (T5)
Ui = 30 V li = 380 mA Pi = 5,32 W Ci = 5 nF Li = desp

0044333 - 2007

IP
66
68

NEPSI

smar LD302 Pressure Transmitter
BR - 14160



NEPSI GYJ071319

FISCO Field Device - Ex ia IIC T4
EEx ia IIC T4/T5/T6

For the Tamb see certificate
Li = neg Ci = 5 nF
Ui = 16 V li = 250 mA Pi = 2,0 W, T4

0044333 - 2007

IP
66
67

WITHOUT APPROVAL

smar LD302 Pressure Transmitter
BR - 14160

0044333 - 2007

- Identification of Intrinsically safe and Explosion Proof for saline atmospheres:

FM

smar LD302 Pressure Transmitter
BR - 14160
Made in Brazil

Temp. Class: T4	XP CL I, DIV 1, GP A,B,C,D.
Tamb. 60°C max.	DIP CL II,III, DIV 1, GP E,F,G.
Vmax. 24 VDC	S CL III, DIV 1.
I max. 250 mA	IS CL I,II,III, DIV 1, GP A,B,C,D,E,F,G.
Ci 5 nF	NI CL I, DIV 2, GP A,B,C,D.
Li 8 uH	Per inst. dwg 102A0078. Pmax= 5800 psi.

FM APPROVED

Type 4X/6/6P

0044333 - 2007

CSA

smar LD302 Pressure Transmitter
BR - 14160

FISCO Field Device
FNICO Field Device

CSA

XP - CL I DIV 1 GR BCD, CL II DIV 1 GR EFG, CL III DIV 1
NI - CL I DIV 2 GR ABCD
IS - Ex ia - CL I DIV 1 GR ABCD, CL II DIV 1 GR EFG, CL III DIV 1
Vmax=24V I max=380mA Ci=5nF Li=0
T3C Ta=40°C max Inst. Dwg. 102A0552 Pmax=5800psi

Type 4X
Dual Seal (process)
Seal not required (conduit)

0044333 - 2007

NEMKO and EXAM

smar LD302 Pressure Transmitter
BR - 14160
Sertãozinho
Brazil

FISCO Field Device - Ex ia IIC T4
FNICO Field Device - Ex nL IIC T4

Ex II 1/2G Ex ia IIC T4/T5/T6 Ga DMT 00 ATEX E 067 ()
-40°C ≤ Ta ≤ +60°C
Pi = 5,32 W Ui = 24 VDC li = 380 mA Li = neg Ci ≤ 5 nF
Ex II 2G Ex d IIC T6 Gb Nemko 13 ATEX 1574X ()
Tamb = -20°C to 60°C U = 28 VDC

IP66W
IP68W 10m/24h

0000000 - 0000

CEPEL

smar LD302 Transmissor de Pressão
BR - 14160

Segurança

FISCO Field Device - Ex ia IIC T4
FNICO Field Device - Ex nL IIC T4

BR - Ex d IIC T6 CEPEL - EX - 054/98
BR - Ex ia IIC T4/T5 CEPEL - EX - 075/96
Tamb = -20° a 65°C (T4) -20° a 50°C (T5)
Ui = 30 V li = 380 mA Pi = 5,32 W Ci = 5 nF Li = desp

IP 66 W 68 W

0044333 - 2007

Control Drawing

Factory Mutual (FM)

NON HAZARDOUS OR DIVISION 2 AREA

SAFE AREA APPARATUS

UNSPECIFIED, EXCEPT THAT IT MUST NOT BE SUPPLIED FROM, NOR CONTAIN UNDER NORMAL OR ABNORMAL CONDITIONS, A SOURCE OF POTENTIAL IN RELATION TO EARTH IN EXCESS OF 250VAC OR 250VDC.

ASSOCIATED APPARATUS

POWER SUPPLY

FIELDBUS BARRIER

GROUND BUS

OPTIONAL SHIELDING

ASSOCIATED APPARATUS

INTRINSICALLY SAFE APPARATUS

ENTITY VALUES: $C=5nF$ $L=6\mu H$
 $V_{max} 24V$ $I_{max} 250mA$

HAZARDOUS AREA

REQUIREMENTS:

- 1- INSTALLATION MUST BE IN ACCORDANCE WITH THE NATIONAL ELECTRICAL CODE (ANSI/NFPA 70) AND ANSI/ISA-RP12.6
- 2- TRANSMITTER SPECIFICATION MUST BE IN ACCORDANCE TO APPROVAL LISTING.
- 3- ASSOCIATED APPARATUS GROUND BUS TO BE INSULATED FROM PANELS AND MOUNTING ENCLOSURES.
- 4- WIRES: TWISTED PAIR, 22AWG OR LARGER.
- 5- SHIELD IS OPTIONAL. IF USED, BE SURE TO INSULATE THE END NOT GROUNDED.
- 6- CABLE CAPACITANCE AND INDUCTANCE PLUS C_i AND L_i MUST BE SMALLER THAN C_a AND L_a OF THE ASSOCIATED APPARATUS.

COMPONENTS CAN NOT BE SUBSTITUTED WITHOUT PREVIOUS MANUFACTURER APPROVAL.

CLASS I,II,III DIV.1, GROUPS A,B,C,D,E,F & G
MODELS LD292, LD293, LD302 AND LD303 - SERIES
ABSOLUTE, GAGE AND DIFFERENTIAL
PRESSURE AND LEVEL TRANSMITTERS
MAXIMUM WORKING PRESSURE RATING: 40MPa (5800 psi). SEE MANUAL.

APPROVAL CONTROLLED BY C.A.R.

REV.	DESIGN	APPROVED	AREA
6	J.RODRIGO 19/09/05	MISSAWA 19/09/05	ALT-DE-0076/05
5	MOACIR 05/05/03	CASSIOLATO 05/05/03	ALTDE 0043/03
4	MOACIR 08/02/02	CASSIOLATO 08/02/02	ALTDE 0013/02
3	MOACIR 08/02/00	CASSIOLATO 08/02/00	ALTDE 0015/00

DRAWING	DESIGN	VERIFIED	APPROVED
MELONI	M.MISSAWA	SINASTRE	PELUSO
23/03/95	23/03/95	23/03/95	23/03/95

CUSTOMER:
EQUIPMENT: LD292/293/302/303

CONTROL DRAWING

FM

APPROVED

ENTITY PARAMETERS FOR ASSOCIATED APPARATUS

CLASS I,II,III DIV.1
GROUPS A,B,C,D,E,F & G

<p>OPTION 1</p> <p>V_{oc} 024V</p> <p>I_{sc} 0250mA</p> <p>P_o 01,2W</p>	<p>OPTION 2</p> <p>V_{oc} 016V</p> <p>I_{sc} 0250mA</p> <p>P_o 0,2W</p>
-----------------------------------------------------------------------------------------------------------------	----------------------------------------------------------------------------------------------------------------

Ca CABLE CAPACITANCE +5nF

La CABLE INDUCTANCE +6uH

Appendix B

		SRF – Service Request Form Pressure Transmitters		Proposal No.: (1)	
Company:			Unit:		Invoice:
COMMERCIAL CONTACT			CUSTOMER CONTACT		
Full Name:			Full Name:		
Function:			Function:		
Phone:		Extension:		Phone:	
Fax:		Extension:		Fax:	
Email:			Email:		
EQUIPMENT DATA					
Model:		Serial Number:		Sensor Number:	
Technology: () 4-20 mA () HART® () HART® SIS () WIRELESS HART® () ISP () FOUNDATION fieldbus™ () PROFIBUS PA					Firmware Version:
PROCESS DATA					
Process Fluid:					
Calibration Range (4)		Ambient Temperature (°F)		Process Temperature (°F)	
Min.:	Max.:	Min.:	Max.:	Min.:	Max.:
Process Pressure (4)		Static Pressure (4)		Vacuum (4)	
Min.:	Max.:	Min.:	Max.:	Min.:	Max.:
				() Transmitter () Repeater	
Normal Operation Time:				Failure Date:	
FAILURE DESCRIPTION (Please, describe the observed behavior, if it is repetitive, how it reproduces, etc.)					
Did device detect the fail? (2) () Yes () No		What is the final value of the current? (2) _____ mA		What is the message in the display? (2)	
MAINTENANCE INFORMATION					
Did you allow the upgrade in the firmware? () Yes () No			Certification plate: Will it maintained the certification? () Yes () No		
Main board configuration: () Original factory configuration () Default configuration () Special configuration (should be informed by the client. Please, use the space below)					
OBSERVATIONS					
SUBMITTER INFORMATION					
Company:					
Submitted by:		Title:		Section:	
Phone:		Extension:		E-mail:	
Date:		Signature:			
For warranty or non-warranty repair, please contact your representative. Further information about address and contacts can be found on www.smar.com/contactus.asp .					
NOTE					
(1) This field should be filled out by the Smar.		(3) Required for Wireless HART® devices.			
(2) Required for SIS devices.		(4) Required to specify the pressure unit.			

