

LD293

smar

MAR / 15
LD293
VERSION 2



**OPERATION & MAINTENANCE
INSTRUCTIONS MANUAL**

PROFIBUS PA GAGE PRESSURE TRANSMITTER



L D 2 9 3 M E

smar
www.smar.com

Specifications and information are subject to change without notice.
Up-to-date address information is available on our website.

web: www.smar.com/contactus.asp

INTRODUCTION

The **LD293** is from the first generation of Profibus-PA Devices. It is an economical alternative level and gauge pressure transmitter. It is based on a field-proven capacitive sensor that provides reliable operation and high performance. This lightweight design eliminates the need for mounting brackets and transmitter supports in many applications. Its microprocessor-based electronics allows total interchangeability with Smar capacitive sensors. It is automatically corrects sensors characteristics changes caused by temperature fluctuations. The digital technology used in the **LD293** enables the choice of several types of transfer functions, an easy interface between the field and the control room and several interesting features that considerably reduce the installation, operation and maintenance costs.

The **LD293** is part of Smar's complete 303 line of Profibus-PA devices.

Some of the advantages of bi-directional digital communications are known from existing smart transmitter protocols: Higher accuracy, multi-variable access, remote configuration and diagnostics, and multi-dropping of several devices on a single pair of wires.

The system controls variable sampling, algorithm execution and communication so as to optimize the usage of the network, not losing time. Thus, high closed loop performance is achieved.

Using Profibus technology, with its capability to interconnect several devices, very large control schemes can be constructed. In order to be user friendly the function block concept was introduced. The **LD293**, like the rest of the 303 family, has some Function Blocks built in, like Analog Input and Transducer, Physical and Display Block.

The need for implementation of Fieldbus in small as well as large systems was considered when developing the entire 303 line of Profibus-PA devices. They have common features and can configure locally using a magnetic tool, eliminating the need for a configurator or console in many basic applications.

The **LD293** is available as a product on its own, but also replaces the circuit board for the LD291. They use the same sensor board. Refer to the maintenance section of this manual for instructions on upgrading. The **LD293** uses the same hardware and housing for the LD293. The **LD293** is part of SMAR's **Series 303** of Profibus-PA devices.

The **LD293**, like its predecessor LD291, has some built-in blocks, eliminating the need for a separate control device. The communication requirement is considerably reduced, and that means less dead-time and tighter control is achieved, not to mention the reduction in cost. They allow flexibility in control strategy implementation.

Get the best results of the LD293 by carefully reading these instructions.

NOTE

This Manual is compatible with version 2.XX, where 2 notes software version and XX software release. The indication 2.XX means that this manual is compatible with any release of software version 2.

Waiver of responsibility

The contents of this manual abides by the hardware and software used on the current equipment version. Eventually there may occur divergencies between this manual and the equipment. The information from this document are periodically reviewed and the necessary or identified corrections will be included in the following editions. Suggestions for their improvement are welcome.

Warning

For more objectivity and clarity, this manual does not contain all the detailed information on the product and, in addition, it does not cover every possible mounting, operation or maintenance cases.

Before installing and utilizing the equipment, check if the model of the acquired equipment complies with the technical requirements for the application. This checking is the user's responsibility.

If the user needs more information, or on the event of specific problems not specified or treated in this manual, the information should be sought from Smar. Furthermore, the user recognizes that the contents of this manual by no means modify past or present agreements, confirmation or judicial relationship, in whole or in part.

All of Smar's obligation result from the purchasing agreement signed between the parties, which includes the complete and sole valid warranty term. Contractual clauses related to the warranty are not limited nor extended by virtue of the technical information contained in this manual.

Only qualified personnel are allowed to participate in the activities of mounting, electrical connection, startup and maintenance of the equipment. Qualified personnel are understood to be the persons familiar with the mounting, electrical connection, startup and operation of the equipment or other similar apparatus that are technically fit for their work. Smar provides specific training to instruct and qualify such professionals. However, each country must comply with the local safety procedures, legal provisions and regulations for the mounting and operation of electrical installations, as well as with the laws and regulations on classified areas, such as intrinsic safety, explosion proof, increased safety and instrumented safety systems, among others.

The user is responsible for the incorrect or inadequate handling of equipments run with pneumatic or hydraulic pressure or, still, subject to corrosive, aggressive or combustible products, since their utilization may cause severe bodily harm and/or material damages.

The field equipment referred to in this manual, when acquired for classified or hazardous areas, has its certification void when having its parts replaced or interchanged without functional and approval tests by Smar or any of Smar authorized dealers, which are the competent companies for certifying that the equipment in its entirety meets the applicable standards and regulations. The same is true when converting the equipment of a communication protocol to another. In this case, it is necessary sending the equipment to Smar or any of its authorized dealer. Moreover, the certificates are different and the user is responsible for their correct use.

Always respect the instructions provided in the Manual. Smar is not responsible for any losses and/or damages resulting from the inadequate use of its equipments. It is the user's responsibility to know and apply the safety practices in his country.

TABLE OF CONTENTS

SECTION 1 - INSTALLATION	1.1
GENERAL	1.1
MOUNTING	1.1
ELECTRONIC HOUSING	1.8
WIRING	1.9
BUS TOPOLOGY AND NETWORK CONFIGURATION	1.10
INTRINSIC SAFETY BARRIER	1.11
JUMPER CONFIGURATION	1.11
POWER SUPPLY	1.11
INSTALLATION IN HAZARDOUS AREAS	1.12
EXPLOSION/FLAME PROOF	1.12
INTRINSICALLY SAFE	1.12
SECTION 2 - OPERATION	2.1
FUNCTIONAL DESCRIPTION - SENSOR	2.1
FUNCTIONAL DESCRIPTION – ELECTRONICS	2.2
THE DISPLAY	2.3
SECTION 3 - CONFIGURATION	3.1
TRANSDUCER BLOCK	3.1
TRANSDUCER BLOCK DIAGRAM	3.2
PRESSURE TRANSDUCER BLOCK PARAMETER DESCRIPTION	3.2
PRESSURE TRANSDUCER BLOCK PARAMETER ATTRIBUTES	3.5
CYCLIC CONFIGURATION	3.7
HOW TO CONFIGURE THE TRANSDUCER BLOCK	3.7
HOW TO CONFIGURE THE ANALOG INPUT BLOCK	3.15
LOWER AND UPPER TRIM	3.19
PRESSURE TRIM - LD293	3.20
CHARACTERIZATION TRIM	3.23
SENSOR INFORMATION	3.24
TEMPERATURE TRIM	3.25
SENSOR DATA READING	3.25
TRANSDUCER DISPLAY – CONFIGURATION	3.26
DISPLAY TRANSDUCER BLOCK	3.27
DEFINITION OF PARAMETERS AND VALUES	3.28
PROGRAMMING USING LOCAL ADJUSTMENT	3.30
J1 JUMPER CONNECTIONS	3.31
W1 JUMPER CONNECTIONS	3.31
SECTION 4 - MAINTENANCE PROCEDURES	4.1
GENERAL	4.1
DISASSEMBLY PROCEDURE	4.2
SENSOR	4.2
ELECTRONIC CIRCUIT	4.3
REASSEMBLE PROCEDURE	4.3
SENSOR	4.3
ELECTRONIC CIRCUIT	4.3
INTERCHANGEABILITY	4.4
UPGRADING LD291 TO LD293	4.4
RETURNING MATERIALS	4.4
ORDERING CODE FOR HOUSING	4.7
ORDERING CODE FOR SENSOR	4.7
SECTION 5 - TECHNICAL CHARACTERISTICS	5.1
ORDERING CODE	5.5
APPENDIX A - CERTIFICATIONS INFORMATION	A.1
EUROPEAN DIRECTIVE INFORMATION	A.1
HAZARDOUS LOCATIONS GENERAL INFORMATION	A.1
HAZARDOUS LOCATIONS CERTIFICATIONS	A.2
NORTH AMERICAN CERTIFICATIONS	A.2

SOUTH AMERICAN CERTIFICATION.....	A.3
EUROPEAN CERTIFICATIONS.....	A.3
ASIA CERTIFICATIONS.....	A.4
IDENTIFICATION PLATES AND CONTROL DRAWING.....	A.4
IDENTIFICATION PLATES	A.4
CONTROL DRAWING.....	A.8
APPENDIX B – SRF – SERVICE REQUEST FORM.....	B.1

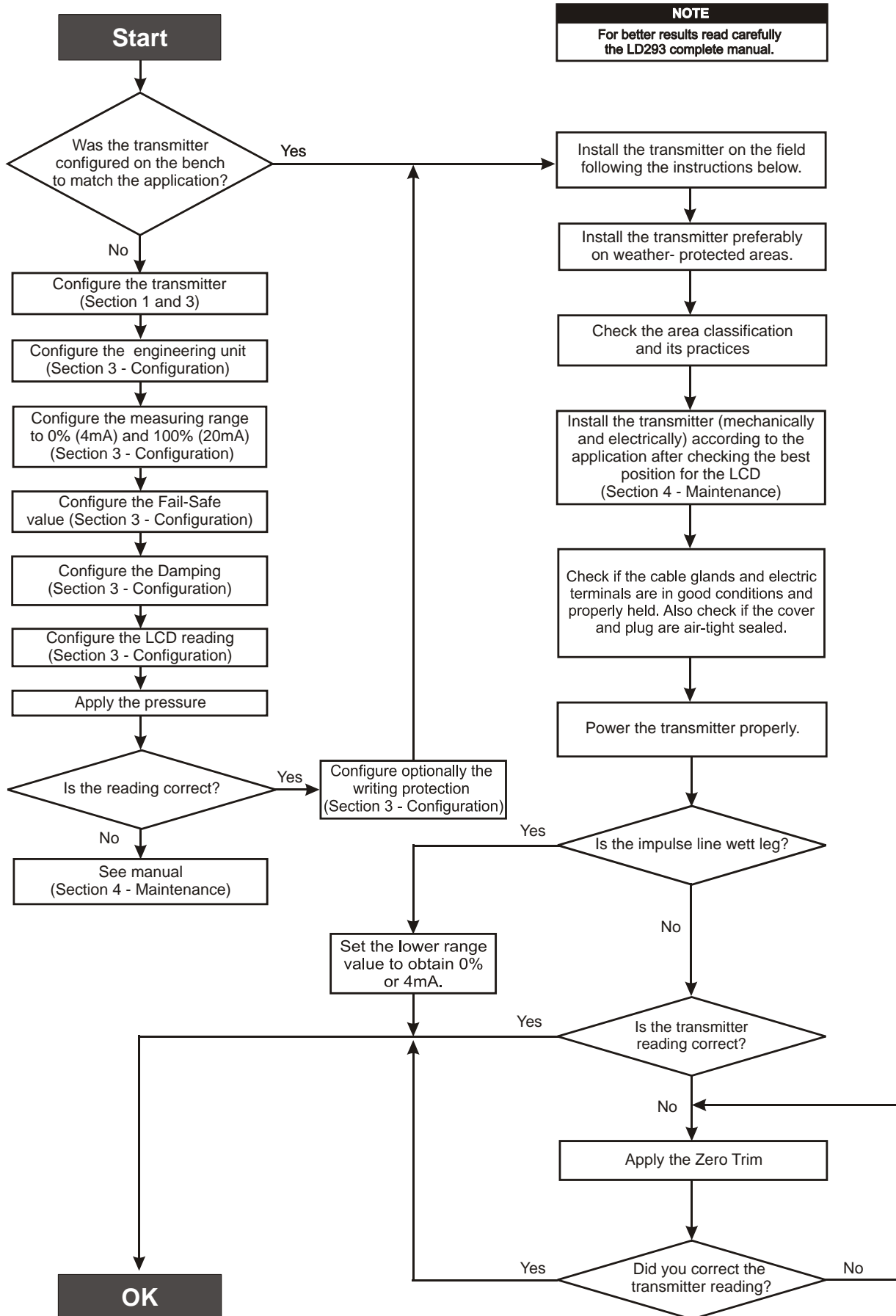

INSTALLATION

General

NOTE
The installation carried out in hazardous areas should follow the recommendations of the IEC60079-14 standard.

The overall accuracy of pressure measurement depends on several variables. Although the transmitter has an outstanding performance, proper installation is essential to maximize its performance.

Among all factors, which may affect transmitter accuracy, environmental conditions are the most difficult to control. There are, however, ways of reducing the effects of temperature, humidity and vibration.

The **LD293** has a built-in temperature sensor to compensate for temperature variations. At the factory, each transmitter is submitted to a temperature cycle process, and the characteristics under different pressures and temperatures are recorded in the transmitter memory. At the field, this feature minimizes the temperature variation effect.

Mounting

Locating the transmitter in areas protected from extreme environmental changes can minimize temperature fluctuation effects.

The transmitter should be installed in such a way as to avoid, as much as possible, direct exposure to the sun or any source of irradiated heat. Installation close to lines and vessels with high temperatures should also be avoided. Use longer sections of impulse piping between tap and transmitter whenever the process fluid is at high temperatures. Use of sunshades or heat shields to protect the transmitter from external heat sources should be considered.

Proper winterization (freeze protection) should be employed to prevent freezing within the measuring chamber, since this will result in an inoperative transmitter and could even damage the cell.

Although the transmitter is virtually insensitive to vibration, installation close to pumps, turbines or other vibrating equipment should be avoided.

The transmitter has been designed to be both rugged and lightweight at the same time. This makes its mounting easier; mounting positions are shown in Figure 1.1 and Figure 1.2.

Should the process fluid contain solids in suspension, install valves or rod-out fittings at regular intervals to clean out the pipes.

The pipes should be internally cleaned by using steam or compressed air, or by draining the line with the process fluid, before such lines are connected to the transmitter (blow-down).

NOTE
When installing or storing the level transmitter, the diaphragm must be protected to avoid scratching-denting or perforation of its surface.

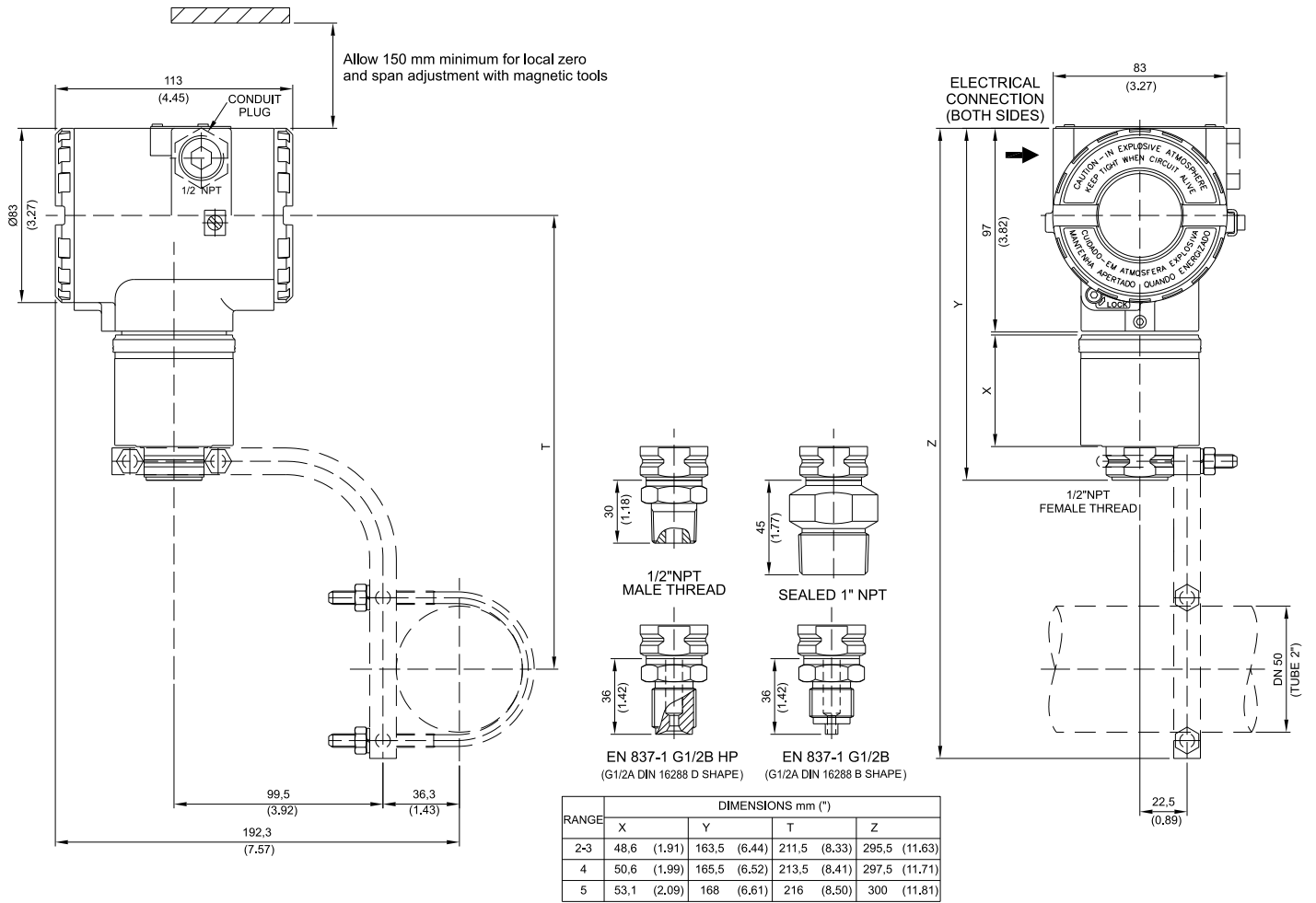

Figure 1.1 (a) - Dimensional Drawing and Mounting Position for LD293

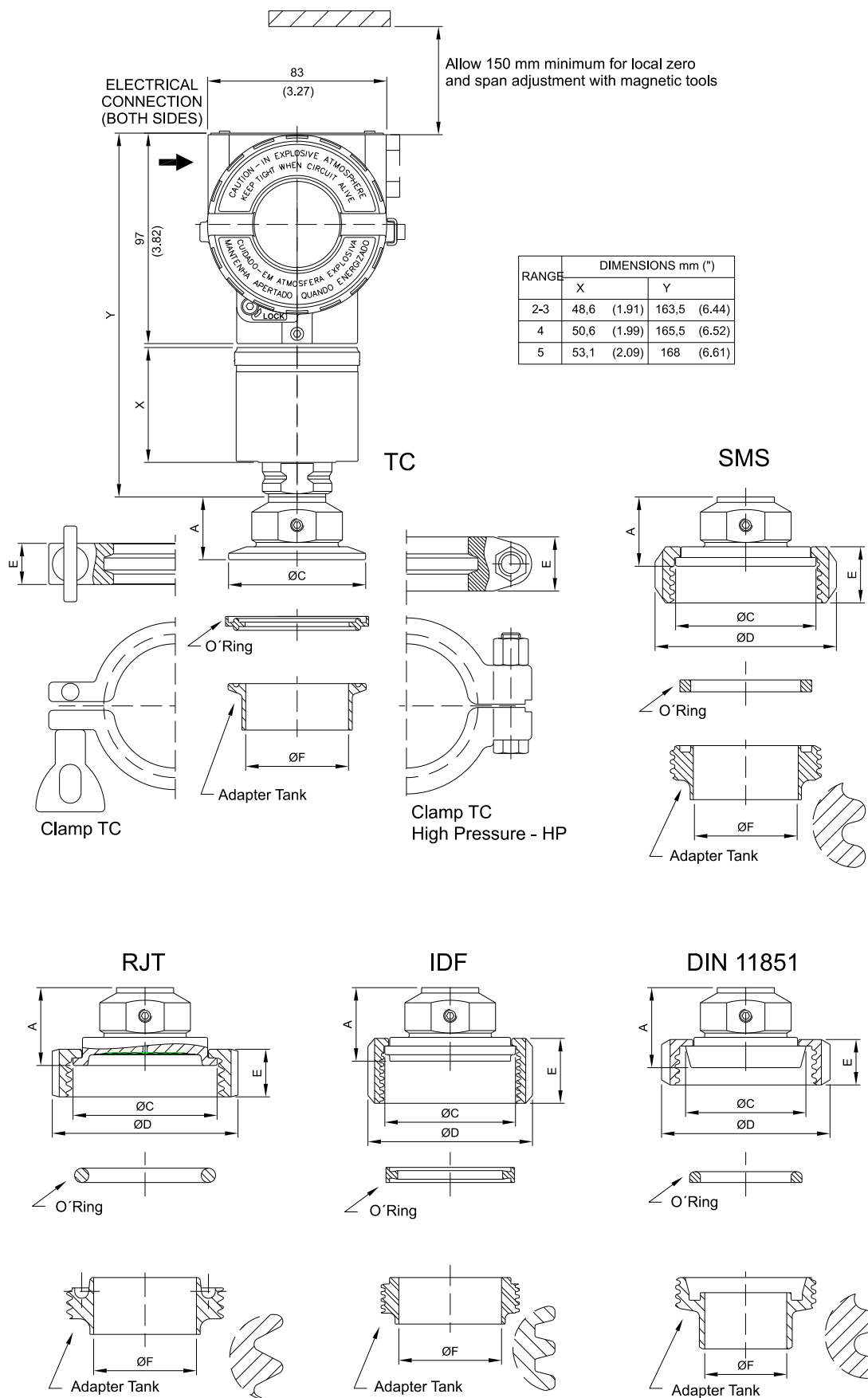
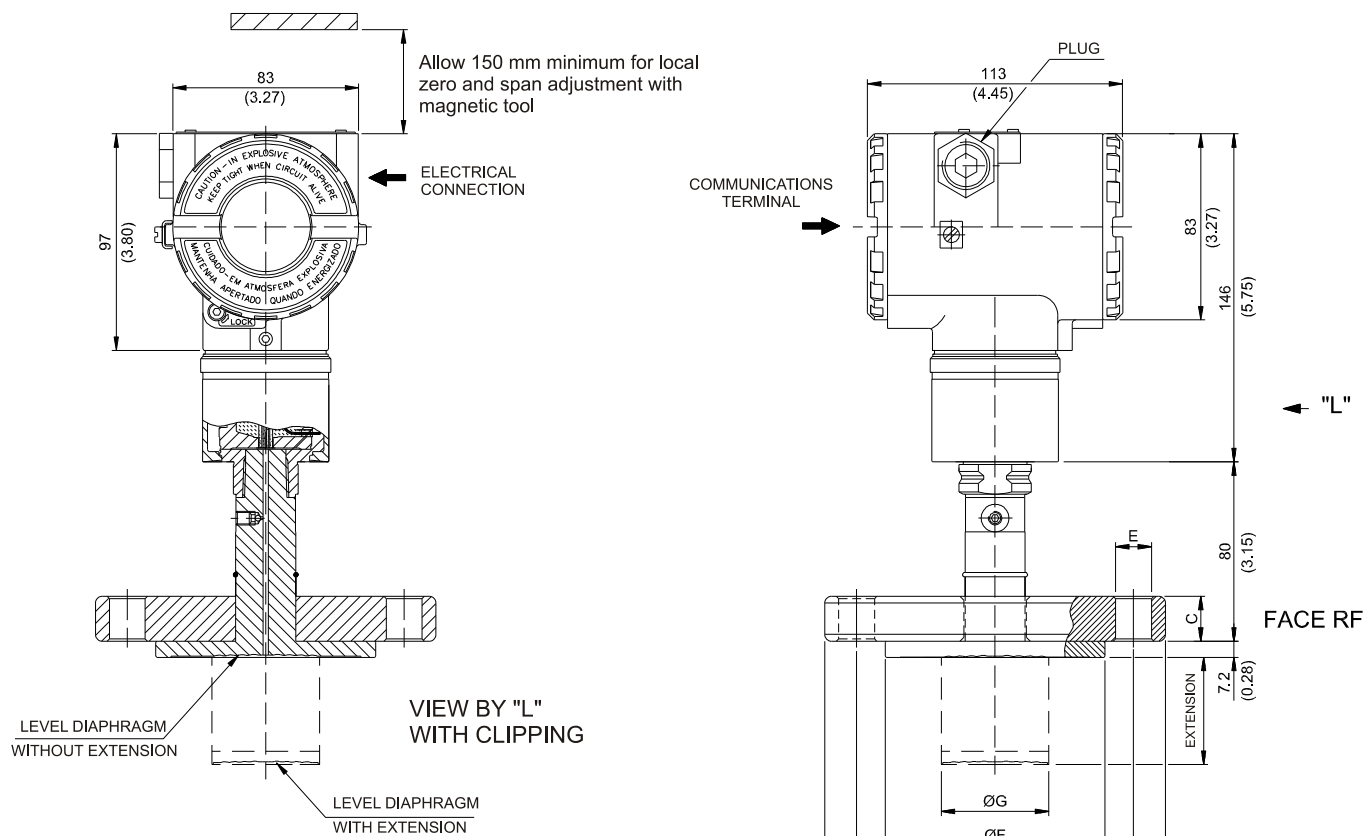

Figure 1.1 (b) - Dimensional Drawing and Mounting Position for LD293 – Sanitary

LD290S - CONNECTIONS					
CONNECTION	Dimensions in mm (inche)				
	A	ØC	ØD	E	ØF
Tri-Clamp - 1 1/2" - without extension	27 (1.06)	50 (1.96)	61 (2.40)	18 (0.71)	35 (1.38)
Tri-Clamp - 1 1/2" HP - without extension	27 (1.06)	50 (1.96)	66 (2.59)	25 (0.98)	35 (1.38)
Tri-Clamp - 2" - without extension	29 (1.14)	63,5 (2.50)	76,5 (3.01)	18 (0.71)	47,6 (1.87)
Tri-Clamp - 2" HP - without extension	29 (1.14)	63,5 (2.50)	81 (3.19)	25 (0.98)	47,6 (1.87)
Threaded DN40 - DIN 11851 - without extension	37 (1.46)	56 (2.20)	78 (3.07)	21 (0.83)	38 (1.50)
Threaded DN50 - DIN 11851 - without extension	38 (1.50)	68,5 (2.70)	92 (3.62)	22 (0.86)	50 (1.96)
Threaded SMS - 1 1/2" - without extension	31 (1.22)	55 (2.16)	74 (2.91)	25 (0.98)	35 (1.38)
Threaded SMS - 2" - without extension	32 (1.26)	65 (2.56)	84 (3.30)	26 (1.02)	48,6 (1.91)
Threaded RJT - 2" - without extension	35 (1.38)	66,7 (2.63)	86 (3.38)	22 (0.86)	47,6 (1.87)
Threaded IDF - 2" - without extension	34 (1.34)	60.5 (2.38)	76 (2.99)	30 (1.18)	47,6 (1.87)

Figure 1.1 (c) - Dimensional Drawing and Mounting Position for LD293 - Sanitary



NOTES:
 -EXTENSION LENGTH mm (in): 0, 50 (1.96), 100 (3.93), 150 (5.9) OR 200 (7.87)
 -DIMENSIONS ARE mm (in)

ANSI-B 16.5 DIMENSIONS								
DN	CLASS	A	B	C	E	F (RF) (FF)	G	HOLES
1"	150	108 (4.25)	79.4 (3.16)	14.3 (0.56)	16 (0.63)	50.8 (2)	-	4
	300/600	124 (4.88)	88.9 (3.5)	17.5 (0.69)	19 (0.75)	50.8 (2)	-	4
1.1/2"	150	127 (5)	98.6 (3.88)	20 (0.78)	16 (0.63)	73.2 (2.88)	40 (1.57)	4
	300	155.4 (6.12)	114.3 (4.5)	21 (0.83)	22 (0.87)	73.2 (2.88)	40 (1.57)	4
	600	155.4 (6.12)	114.3 (4.5)	29.3 (1.15)	22 (0.87)	73.2 (2.88)	40 (1.57)	4
2"	150	152.4 (6)	120.7 (4.75)	17.5 (0.69)	19 (0.75)	92 (3.62)	48 (1.89)	4
	300	165.1 (6.5)	127 (5)	20.7 (0.8)	19 (0.75)	92 (3.62)	48 (1.89)	8
	600	165.1 (6.5)	127 (5)	25.4 (1)	19 (0.75)	92 (3.62)	48 (1.89)	8
3"	150	190.5 (7.5)	152.4 (6)	22.3 (0.87)	19 (0.75)	127 (5)	73 (2.87)	4
	300	209.5 (8.25)	168.1 (6.62)	27 (1.06)	22 (0.87)	127 (5)	73 (2.87)	8
	600	209.5 (8.25)	168.1 (6.62)	31.8 (1.25)	22 (0.87)	127 (5)	73 (2.87)	8
4"	150	228.6 (9)	190.5 (7.5)	22.3 (0.87)	19 (0.75)	158 (6.22)	89 (3.5)	8
	300	254 (10)	200 (7.87)	30.2 (1.18)	22 (0.87)	158 (6.22)	89 (3.5)	8
	600	273 (10.75)	215.9 (8.5)	38.1 (1.5)	25 (1)	158 (6.22)	89 (3.5)	8

EN 1092-1 / DIN2501 DIMENSIONS								
DN	PN	A	B	C	E	F	G	HOLES
25	10/40	115 (4.53)	85 (3.35)	18 (0.71)	14 (0.55)	68 (2.68)	-	4
40	10/40	150 (5.9)	110 (4.33)	20 (0.78)	18 (0.71)	88 (3.46)	40 (1.57)	4
50	10/40	165 (6.50)	125 (4.92)	20 (0.78)	18 (0.71)	102 (4.01)	48 (1.89)	4
80	10/40	200 (7.87)	160 (6.30)	24 (0.95)	18 (0.71)	138 (5.43)	73 (2.87)	8
100	10/16	220 (8.67)	180 (7.08)	20 (0.78)	18 (0.71)	158 (6.22)	89 (3.5)	8
	25/40	235 (9.25)	190 (7.50)	24 (0.95)	22 (0.87)	162 (6.38)	89 (3.5)	8

Figure 1.1 (d) - Dimensional Drawing and Mounting Position for LD293 – Level

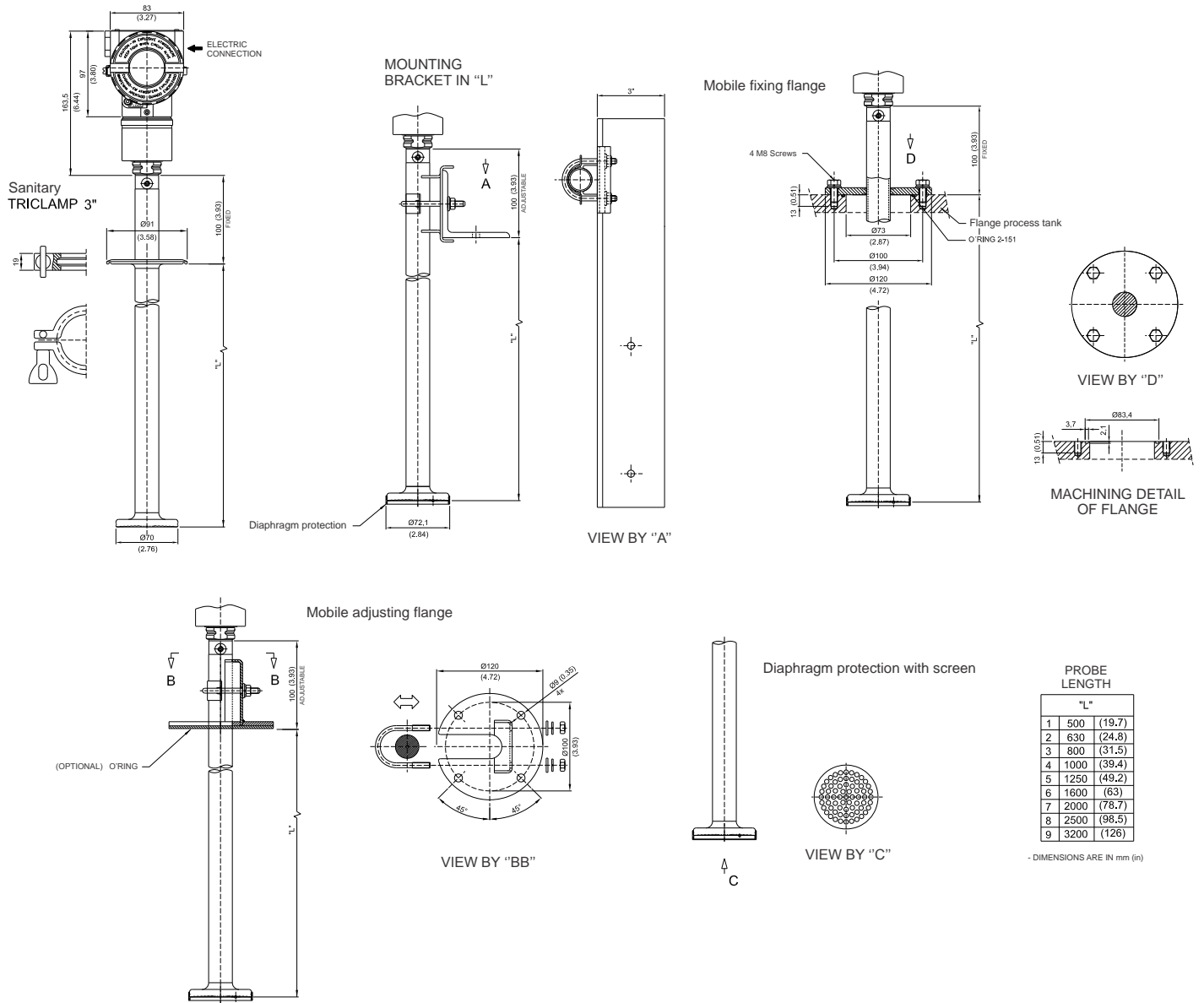

Figure 1.1 (e) - Dimensional Drawing and Mounting Position for LD293 – Level (Insertion)

The figure 1.2 shows how to use the tool to fix the process transmitter tap.

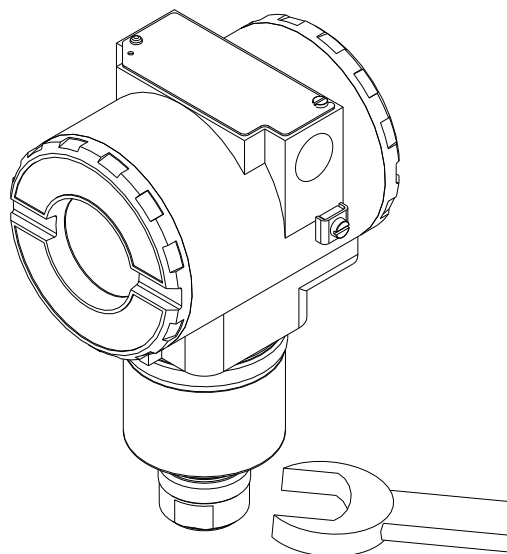

Figure 1.2 – Fixing of the Transmitter in the Tap

Observe operating safety rules during wiring, draining or blow-down.

WARNING	
Normal safety precautions must be taken to avoid the possibility of an accident occurring when operating in conditions of high pressure and/or temperature.	
Electrical shock can result in death or serious injury. Avoid contact with the leads and terminals.	
Process leaks could result in death or serious injury. Do not attempt to loosen or remove flange bolts while the transmitter is in service.	
Replacement equipment or spare parts not approved by Smar could reduce the pressure retaining capabilities of the transmitter and may render the instrument dangerous. Use only bolts supplied or sold by Smar as spare parts.	

Some examples of installation, illustrating the position of the transmitter in relation to the taps, are shown in Figure 1.3.

The location of pressure taps and the relative position of the transmitter are indicated in Table 1.1.

Process Fluid	Location of Taps	Location for the LD293 in Relation to the Taps
Gas	Top or Side	Above the Taps
Liquid	Side	Below the Taps or at the Piping Centerline
Steam	Side	Below the Taps using Sealing (Condensate) Pots

Table 1.1 - Location of Pressure Taps

NOTE	
Except for dry gases, all impulse lines should slope at the ratio 1:10, in order to avoid trapping bubbles in the case of liquids, or condensation from steam or wet gases.	

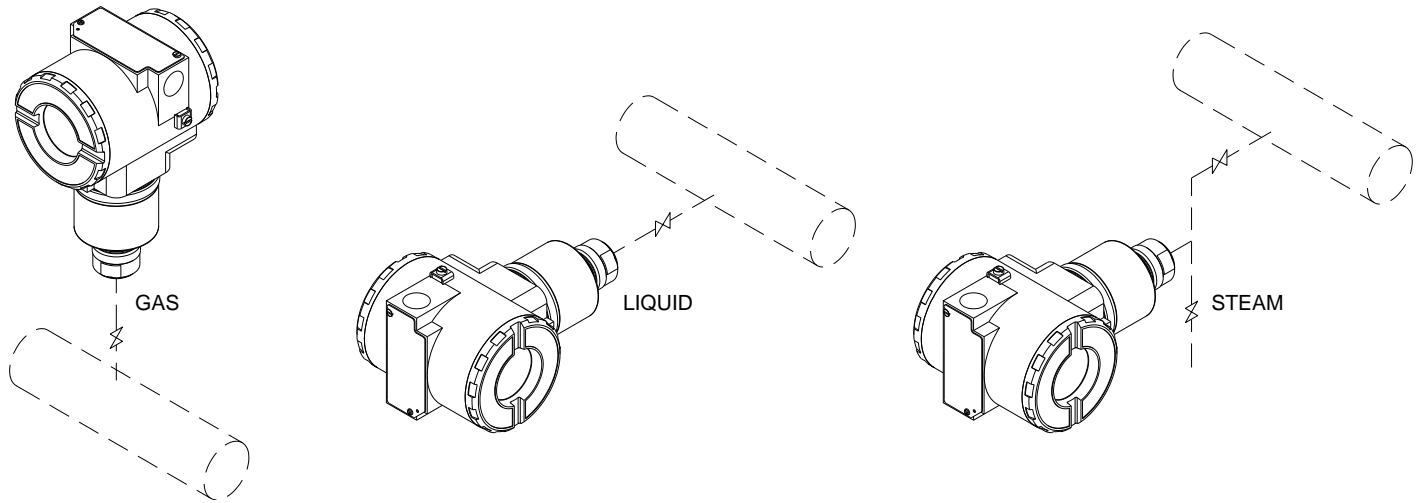
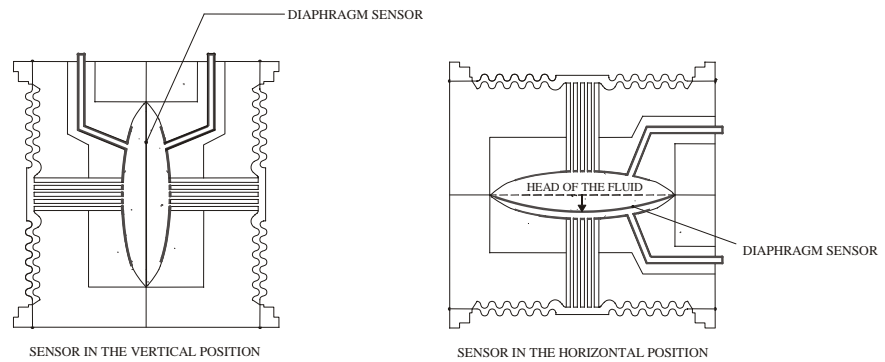

Figure 1.3 - Position of the Transmitter and Taps

NOTE

The transmitters are calibrated in the vertical position and a different mounting position displaces the zero point. Consequently, the indicator will indicate a different value from the applied pressure. In these conditions, it is recommended to do the zero pressure trim. The zero trim is to compensate the final assembly position and its performance, when the transmitter is in its final position. When the zero trim is executed, make sure the equalization valve is open and the wet leg levels are correct.

For the absolute pressure transmitter, the assembly effects correction should be done using the Lower trim, due to the fact that the absolute zero is the reference for these transmitters, so there is no need for a zero value for the Lower trim.



Electronic Housing

Humidity is fatal for electronic circuits. In areas subjected to high relative humidity, the O-rings for the electronic housing covers must be correctly placed and the covers must be completely closed by tightening them by hand until the O-rings are compressed.

Do not use tools to close the covers. Removal of the electronics cover in the field should be reduced to the minimum necessary, as each time it is removed; the circuits are exposed to the humidity. The electronic circuit is protected by a humidity proof coating, but frequent exposure to humidity may affect the protection provided. It is also important to keep the covers tightened in place. Every time they are removed, the threads are exposed to corrosion, since painting cannot protect these parts. Code-approved sealing methods should be employed on conduit entering the transmitter.

WARNING

The unused cable entries should be plugged and sealed accordingly to avoid humidity entering, which can cause the loss of the product's warranty.

The electronic housing can be rotated to adjust the digital display on a better position. To rotate it, loose the Housing Rotation Set Screw, see Figure 1.4 (a). To prevent humidity entering, the electric housing and the sensor joint must have a minimum of 6 fully engaged threads. The provided joint allows 1 extra turn to adjust the position of the display window by rotating the housing clockwise. If the thread reaches the end before the desired position, then rotate the housing counterclockwise, but not more than one thread turn. Transmitters have a stopper that restricts housing rotation to one turn. See Section 4, Figure 4.1.

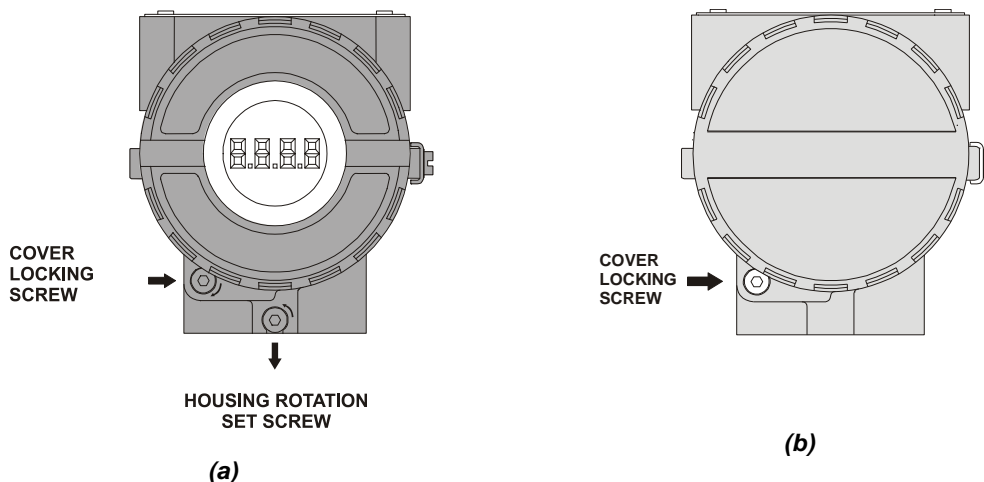

Figure 1.4 - Cover Locking and Housing Rotating Set Screw (a) Electronic Board Side (b) Terminal Connection Side

Wiring

To access the wiring block, loosen the cover locking screw to release the cover. See Figure 1.4 (b).

The **LD293** is protected against reverse polarity, and can withstand ± 35 VDC without damage, but it will not operate when in reverse polarity.

For convenience there are three ground terminals: one inside the cover and two externals, located close to the conduit entries. See Figure 1.5.

The **LD293** uses the 31.25 kbit/s voltage mode option for the physical signaling. All other devices on the same bus must use the same signaling. All devices are connected in parallel along the same pair of wires.

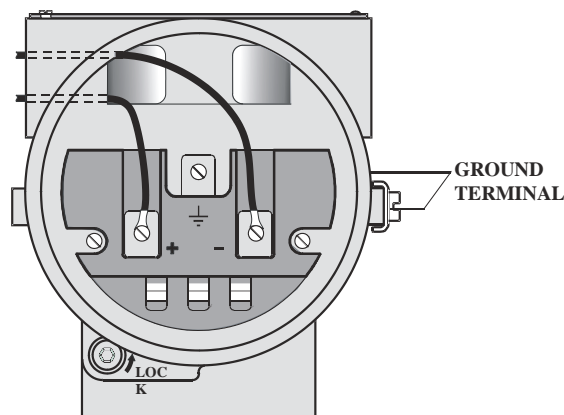

Figure 1.5 - Terminal Block

Various types of Profibus devices may be connected on the same bus.

The **LD293** is powered via the bus. The limit for such devices is according to the DP/PA coupler limitation for one bus for non-intrinsically safe requirement.

In hazardous area, the number of devices may be limited by intrinsically safe restrictions, according to the DP/PA coupler and barriers limitation.

The Figure 1.6 shows the correct installation of the conduit, in order to avoid penetration of water, or other substance, which may cause malfunctioning of the equipment.

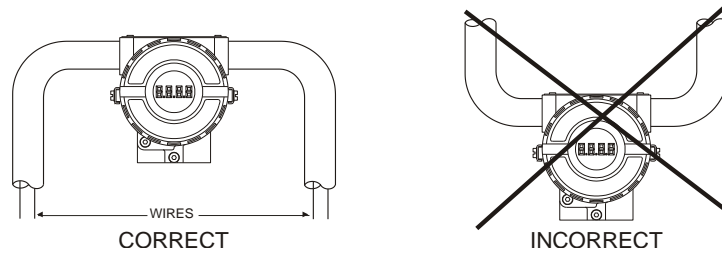

Figure 1.6 - Conduit Installation

NOTE

For more installation details please refer to the Profibus Installation Manual

Bus Topology and Network Configuration

Other types of cable may be used, other than for conformance testing. Cables with improved specifications may enable longer trunk length or superior interface immunity. Conversely, cables with inferior specifications may be used subject to length limitations for trunk and spurs plus possible nonconformance to the RFI/EMI susceptibility requirements. For intrinsically safe applications, the inductance/ resistance ratio (L/R) should be less than the limit specified by the local regulatory agency for the particular implementation.

Bus topology (See Figure 1.8) and tree topology (See Figure 1.9) are supported. Both types have a trunk cable with two terminations. The devices are connected to the trunk via spurs. The spurs may be integrated in the device giving zero spur length. A spur may connect more than one device, depending on the length. Active couplers may be used to extend spur length.

Active repeaters may be used to extend the trunk length. The total cable length, including spurs, between any two devices in the Fieldbus should not exceed 1900 m.

The connection of couplers should be kept less than 15 per 250 m. In following figures the DP/PA link depends on the application needs.

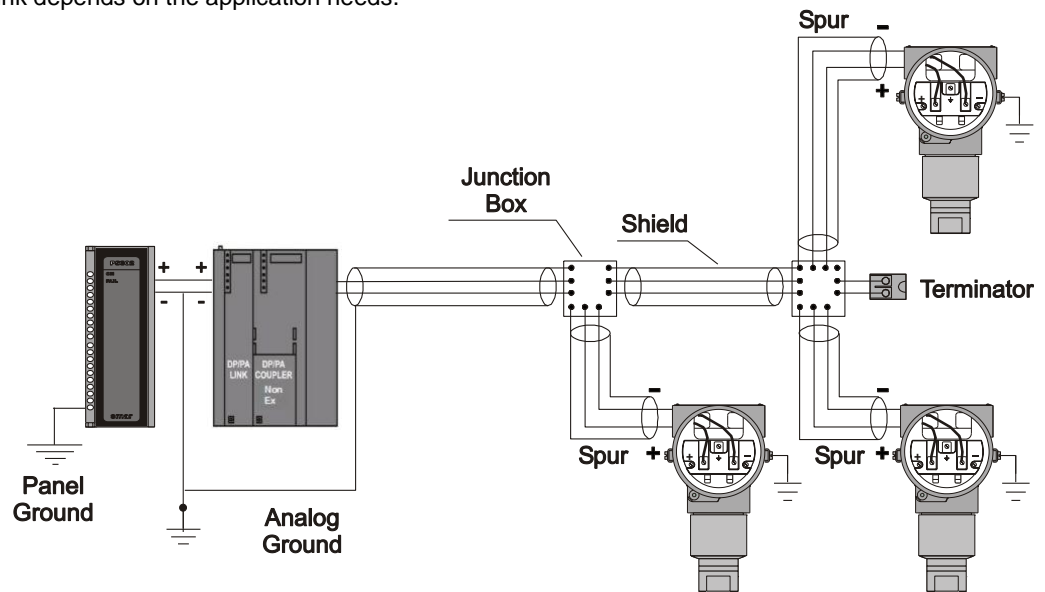

Figure 1.8 - Bus Topology

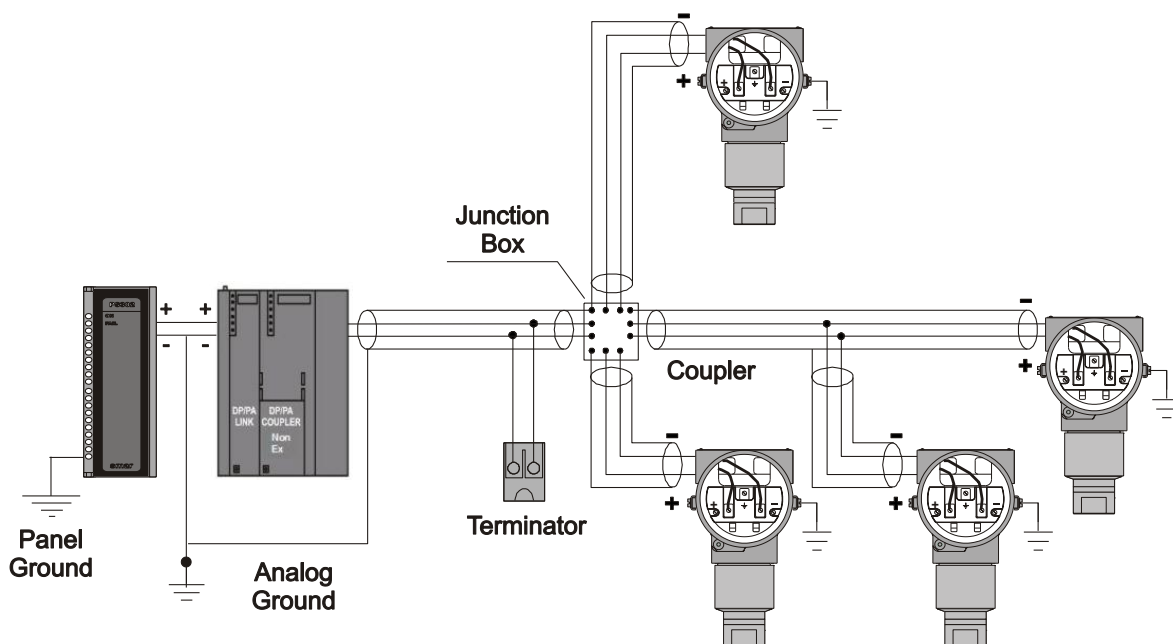

Figure 1.9 - Tree Topology

Intrinsic Safety Barrier

When the Fieldbus is in an area requiring intrinsic safety, a barrier must be inserted on the trunk between the power supply and the DP/PA coupler, when it is Non-Ex type.

Use of SB312LP or DF47 is recommended. For more information, consult <http://www.smar.com/products/df47-12.asp> and <http://www.smar.com/products/sb312lp.asp>.

Jumper Configuration

In order to work properly, the jumpers J1 and W1 located in the LD293 main board must be correctly configured (See Table 1.2 - Description of the Jumpers).

J1	This jumper enables the simulation mode parameter in the AI block.
W1	This jumper enables the local adjustment programming tree.

Table 1.2 - Description of the Jumpers

Power Supply

The LD293 receives power from the bus via the signal wiring. The power supply may come from a separate unit or from another device such as a controller or DCS.

The voltage should be between 9 to 32 Vdc for non-intrinsic safe applications.

A special requirement applies to the power supply used in an intrinsically safe bus and depends on the type of barrier used.

Use of PS302 is recommended as power supply.

Installation in Hazardous Areas

WARNING

Explosions could result in death or serious injury, besides financial damage. Installation of this transmitter in explosive areas must be carried out in accordance with the local standards and the protection type adopted. Before continuing the installation make sure the certificate parameters are in accordance with the classified area where the equipment will be installed.

The instrument modification or parts replacement supplied by other than authorized representative of Smar is prohibited and will void the certification.

The transmitters are marked with options of the protection type. The certification is valid only when the protection type is indicated by the user. Once a particular type of protection is selected, any other type of protection can not be used.

The electronic housing and the sensor installed in hazardous areas must have a minimum of 6 fully engaged threads. Lock the housing using the locking screw (Figure 1.4).

The cover must be tightened with at least 8 turns to avoid the penetration of humidity or corrosive gases. The cover must be tightened until it touches the housing. Then, tighten more 1/3 turn (120°) to guarantee the sealing. Lock the covers using the locking screw (Figure 1.4).

Consult the Appendix A for further information about certification.

Explosion/Flame Proof

WARNING

Only use Explosion Proof/Flameproof certified Plugs, Adapters and Cable glands.

In Explosion-Proof installations the cable entries must be connected or closed using metal cable gland and metal blanking plug, both with at least IP66 and Ex-d certification.

The standard plugs provided by Smar are certified according to CEPEL certificate. If the plug needs to be replaced, a certified plug must be used.

The electrical connection with NPT thread must use waterproofing sealant. A non-hardening silicone sealant is recommended.

For NEMKO ATEX certificate please to follow the installation guidelines in hazardous locations below: Group II Category 2G, Ex d, Group IIC, Temperature Class T6, EPL Gb U = 28VDC

Ambient Temperature: -20 to 60°C for T6

Environmental Protection: IP66/687 or IP66W/687W

The electrical connection available are ½ - 14NPT and M20x1,5.

Cable entries must be connected or closed using metal cable gland and metal blanking plug, both with at least IP66 and Ex-d certification or any appropriate ATEX approved metal cable gland and metal blanking plug. Do not remove the transmitter covers when power is ON.

Intrinsically Safe

WARNING

In hazardous zones with intrinsically safe or non-incendive requirements, the circuit entity parameters and applicable installation procedures must be observed.

To protect the application the transmitter **must be connected to a barrier**. Match the parameters between barrier and the equipment (Consider the cable parameters). Associated apparatus ground bus shall be insulated from panels and mounting enclosures. Shield is optional. If used, be sure to insulate the end not grounded. Cable capacitance and inductance plus C_i and L_i must be smaller than C_o and L_o of the associated Apparatus.

It is not recommended to remove the transmitter cover when the power is ON.

OPERATION

The **LD293** Series Pressure Transmitters use capacitive sensors (capacitive cells) as pressure sensing elements, as shown in Figure 2.1. This is exactly the same sensor as the LD301 series uses, the sensor modules are therefore interchangeable.

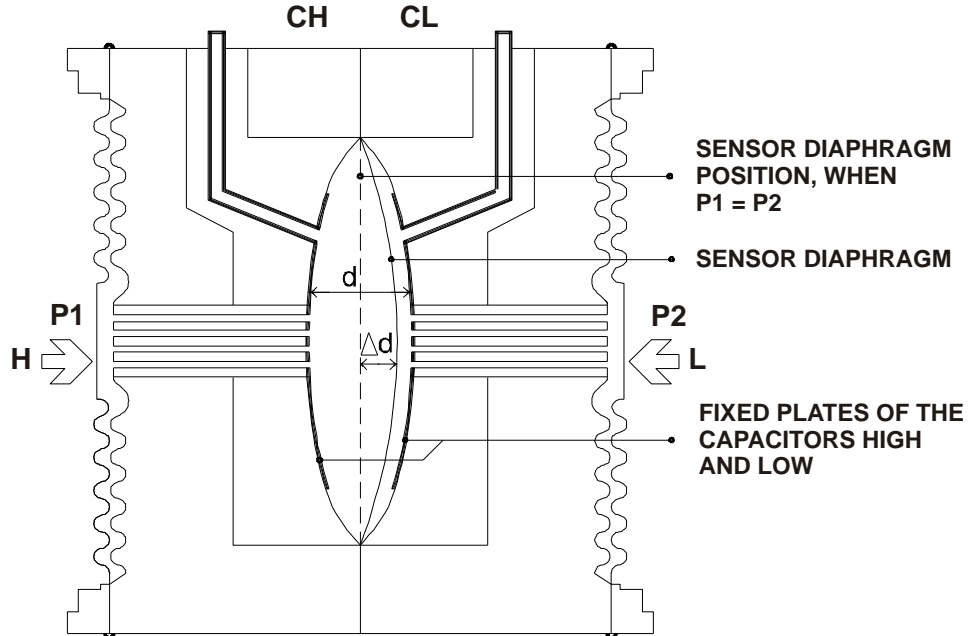

Figure 2.1 - Capacitive Cell

Functional Description - Sensor

Where,

P_1 and P_2 are the pressures and $P_1 \geq P_2$

CH = Capacitance between the fixed plate on P_1 side and the sensing diaphragm.

CL = Capacitance between the fixed plate on the P_2 side and the sensing diaphragm.

d = Distance between CH and CL fixed plates.

Δd = Sensing diaphragm's deflection due to the differential pressure $\Delta P = P_1 - P_2$.

Knowing that the capacitance of a capacitor with flat, parallel plates may be expressed as a function of plate area (A) and distance (d) between the plates:

$$C \approx \frac{\epsilon \times A}{d}$$

Where,

ϵ = Dielectric constant of the medium between the capacitor's plates.

However, should CH and CL be considered as capacitances of flat and parallel plates with identical areas, when $P_1 > P_2$ have:

$$CH \approx \frac{\epsilon \times A}{(d/2) + \Delta d} \quad \text{and} \quad \frac{\epsilon \times A}{(d/2) - \Delta d} \approx CL$$

However, should the differential pressure (ΔP) applied to the capacitive cell not deflect the sensing diaphragm beyond $d/4$ it is possible to assume ΔP as proportional to Δd .

By developing the expression $(C_L - C_H) / (C_L + C_H)$, it follows that:

$$\frac{C_L - C_H}{C_L + C_H} = \frac{2\Delta d}{d}$$

As the distance (d) between the fixed plates CH and CL is constant. It is possible to conclude that the expression $(C_L - C_H) / (C_L + C_H)$ is proportional to Δd and, therefore, to the differential pressure to be measured.

Thus it is possible to conclude that the capacitive cell is a pressure sensor formed by two capacitors whose capacitances vary according to the applied differential pressure.

Functional Description – Electronics

Refer to the block diagram Figure 2.2. The function of each block is described below.

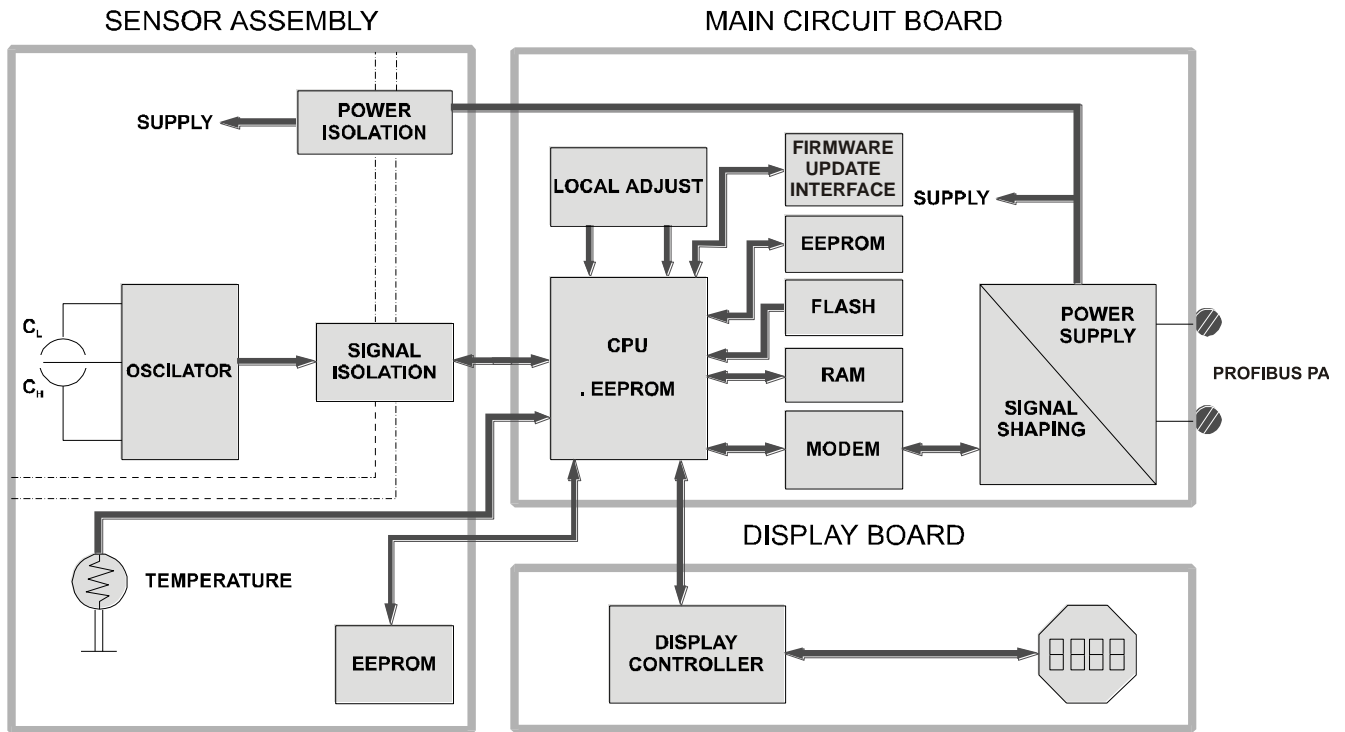

Figure 2.2 - LD293 Block Diagram Hardware

Oscillator

This oscillator generates a frequency as a function of sensor capacitance.

Signal Isolator

The control signals from the CPU and the signal from the oscillator are isolated to avoid ground loops.

Central Processing Unit (CPU), RAM, FLASH and EEPROM

The CPU is the intelligent portion of the transmitter, being responsible for the management and operation of measurement, block execution, self-diagnostics and communication. The program is stored in a FLASH memory for easy upgrade and saving data on power-down event occurrence. For temporary storage of data there is a RAM. The data in the RAM is lost if the power is switched off, however the main board has a nonvolatile EEPROM memory where the static data configured that must be retained is stored. Examples of such data are the following: calibration, links and identification data.

Sensor EEPROM

Another EEPROM is located within the sensor assembly. It contains data pertaining to the sensor's characteristics at different pressures and temperatures. This characterization is done for each sensor at the factory. It also contains the factory settings; they are useful in case of main board replacement, when it does an automatic upload of data from the sensor board to main board.

Fieldbus Modem

Monitors line activity, modulate and demodulate communication signals, inserts and deletes start and end delimiters, and checks integrity of frame received.

Power Supply

Takes power of the loop-line to power the transmitter circuitry.

Power Isolation

Isolates the signals to and from the input section, the power to the input section must be isolated.

Display Controller

Receives data from the CPU identifying which segments on the liquid crystal Display use to turn on. The controller drives the backplane and the segment control signals.

Local Adjustment

There are two switches that are magnetically activated. The magnetic tool without mechanical or electrical contact can activate them.

The Display

The integral indicator is able to display one or two variables, which are user selectable. When two variables are chosen, the display will alternate between the two with an interval of 3 seconds.

The liquid crystal display includes a field with 4 ½ numeric digits, a field with 5 alphanumeric digits and an information field, as shown on Figure 2.3.

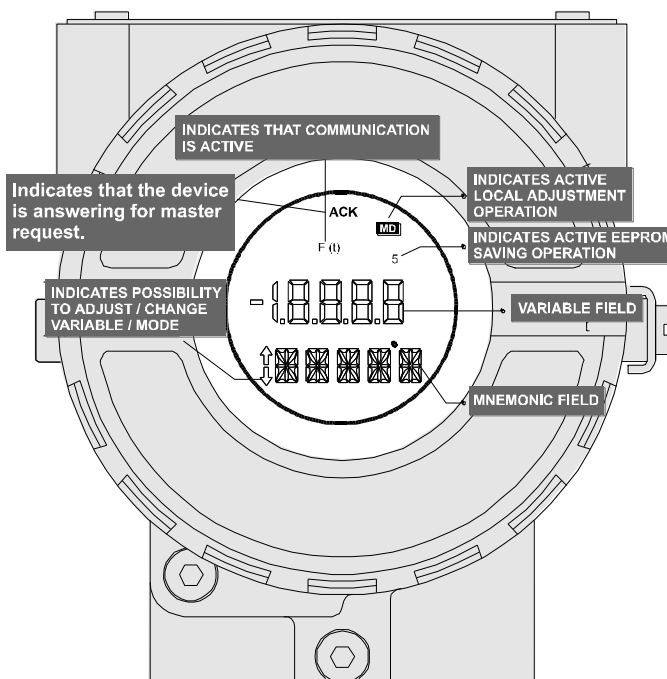

Figure 2.3 - LCD Display

CONFIGURATION

This section describes the characteristics of the blocks in the **LD293**. They follow the Profibus PA specifications, but in terms of transducer blocks, the input transducer block and display, they have some special features on top of this.

The 303 Smar family is integrated in Profibus View, from Smar and Simatic PDM, from Siemens. It is possible to integrate any 303 Smar device into any configuration tool for Profibus PA devices. It is necessary to provide a Device Description or Drive according to the configuration tool. In this manual is taken several examples using Profibus View and Simatic PDM.

In order to assure correct values in the offline configuration, first run "Download to PG/PC" option to assure valid values. After, run the Menu Device option to configure the required parameters using the related menus.

NOTE
In offline configuration, it is not advisable to use the "Download to Device" option. This function can misconfigure the equipment.

Transducer Block

Transducer block insulates function block from the specific I/O hardware, such as sensors, actuators. Transducer block controls access to I/O through manufacturer specific implementation. This permits the transducer block to execute as frequently as necessary to obtain good data from sensors without burdening the function blocks that use the data. It also insulates the function block from the manufacturer specific characteristics of certain hardware.

By accessing the hardware, the transducer block can get data from I/O or passing control data to it. The connection between Transducer block and Function block is called channel. These blocks can exchange data from its interface.

Normally, transducer blocks perform functions, such as linearization, characterization, temperature compensation, control and exchange data to hardware.

Transducer Block Diagram

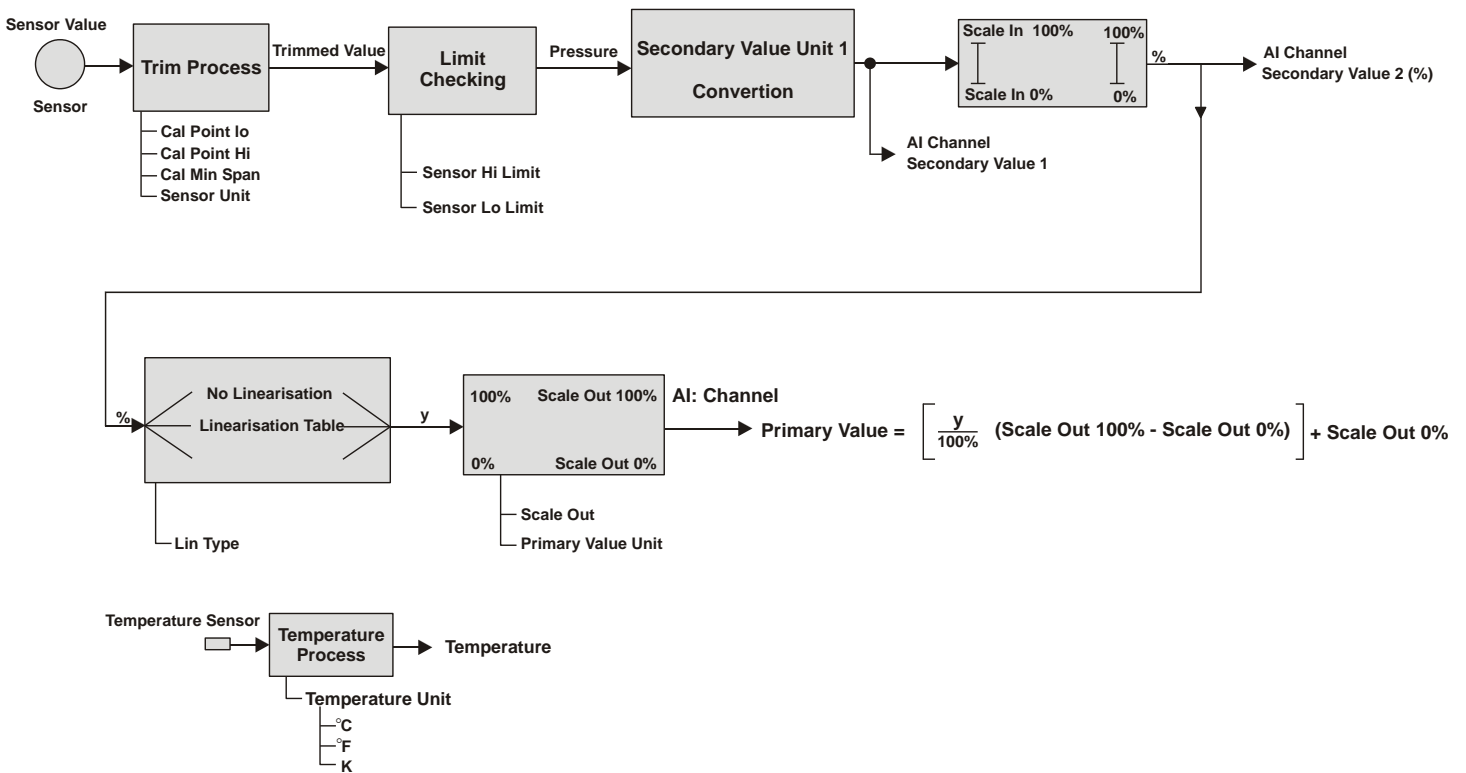

Figure 3.1 – Transducer Block Diagram

Pressure Transducer Block Parameter Description

Parameter	Description
BACKUP_RESTORE	This parameter allows to save and to restore data according to factory and user calibration procedures. It has the following options: 1, "Factory Cal Restore", 2, "Last Cal Restore", 3, "Default Data Restore", 4, "Shut-Down Data Restore", 5, "Sensor Data Restore", 11, "Factory Cal Backup", 12, "Last Cal Backup", 14, "Shut-Down Data Backup", 15, "Sensor Data Backup", 0, "None".
CAL_MIN_SPAN	This parameter contains the minimum calibration span value allowed. This minimum span information is necessary to ensure that when calibration is done, the two calibrated points (high and low) are not too close together. Unit derives from SENSOR_UNIT.
CAL_POINT_HI	This parameter contains the highest calibrated value. For calibration of the high limit point you give the high measurement value (pressure) to the sensor and transfer this point as HIGH to the transmitter. Unit derives from SENSOR_UNIT.
CAL_POINT_LO	This parameter contains the lowest calibrated value. For calibration of the low limit point you give the low measurement value (pressure) to the sensor and transfer this point as LOW to the transmitter. Unit derives from SENSOR_UNIT.
CAL_TEMPERATURE	This parameter contains the calibrated temperature value. Unit derives from TEMPERATURE_UNIT.
COEFF_POL	This parameter contains the polynomial coefficients.

Parameter	Description
EEPROM_FLAG	This parameter is used to indicate EEPROM saving process. { 0, "False" } { 1, "True" }
FACTORY_CURVE_BYPASS	This parameter is used to enable factory characterization curve. { 85, "Disable" } { 170, "Enable and Backup Cal" } { 4010, "Disable and Restore Cal" } { 61440, "Disable or Allows to enter the points" }
FACTORY_CURVE_X	This parameter contains input points of factory characterization curve.
FACTORY_CURVE_Y	This parameter contains input points of factory characterization curve.
FACTORY_CURVE_LENGTH	This parameter contains the number of points of factory characterization curve
LIN_TYPE	Linearization – Type: 0 – No Linearization 1 – User Defined Table
MAIN_BOARD_SN	This is the main board serial number.
MAX_SENSOR_VALUE	Holds the maximum process SENSOR_VALUE. A write access to this parameter resets to the momentous value. The unit is defined in SENSOR_UNIT.
MIN_SENSOR_VALUE	Holds the minimum process SENSOR_VALUE. A write access to this parameter resets to the momentous value. The unit is defined in SENSOR_UNIT.
MAX_TEMPERATURE	Holds the maximum temperature. A write access to this parameter resets to the momentous value.
MIN_TEMPERATURE	Holds the minimum temperature. A write access to this parameter resets to the momentous value.
ORDERING_CODE	Indicates information about the sensor and control from production factory.
POLYNOMIAL_VERSION	Indicates the polynomial version.
PRESS_LIN_NORMAL	Indicates the Linear Normalized Pressure.
PRESS_NORMAL	Indicates Normalized Pressure.
PRIMARY_VALUE	This parameter contains the measured value and status available to the Function Block. The unit of PRIMARY_VALUE is the PRIMARY_VALUE_UNIT.
PRIMARY_VALUE_TYPE	This parameter contains the application of the pressure device. 0: Pressure 4-127: reserved > 128: manufacture specific
PRIMARY_VALUE_UNIT	This parameter contains the engineering units index code for the primary value. See explanation about Primary_Value_Unit.
PROCESS_CONNECTION_MATERIAL	Not used.
PROCESS_CONNECTION_TYPE	Not used.
SCALE_IN	This is the input conversion of the Pressure into SECONDARY_VALUE_2 using the high and low scale. The related unit is the SECONDARY_VALUE_1_UNIT.
SCALE_OUT	This is the output conversion of the linearized value using the high and low scale. The related unit is the PRIMARY_VALUE_UNIT.
SECONDARY_VALUE_1	This parameter contains the Pressure value and status available to the Function Block.
SECONDARY_VALUE_1_UNIT	This parameter contains the pressure units of the SECONDARY_VALUE_1.
SECONDARY_VALUE_2	This parameter contains the measured value after input scaling and status available to the Function Block. The related unit is the SECONDARY_VALUE_UNIT_2.
SECONDARY_VALUE_2_UNIT	This parameter contains the units of the SECONDARY_VALUE_2 defined by the manufacturer
SENSOR_DIAPHRAGM_MATERIAL	This parameter contains the index code for the material of the diaphragm, which comes in contact with the process media.
SENSOR_FILL_FLUID	This parameter contains the index code for the fill fluid inside the sensor. The index code is manufacture's specific.
SENSOR_MAX_STATIC_PRESSURE	Not used.
SENSOR_O_RING_MATERIAL	Not used.
SENSOR_HI_LIM	This parameter contains the sensor upper limit value. Unit derives from SENSOR_UNIT.

Parameter	Description
SENSOR_LO_LIM	This parameter contains the sensor lower limit value. Unit derives from SENSOR_UNIT.
SENSOR_RANGE_CODE	Indicates the sensor range code. { 0, "Range 1 (20 inH2O)" }, { 1, "Range 2 (200 inH2O)" }, { 2, "Range 3 (1000 inH2O)" }, { 3, "Range 4 (360 psi)" }, { 4, "Range 5 (3600 psi)" }, { 5, "Range 6 (5800 psi)" }, { 253, "Special" }
SENSOR_SERIAL_NUMBER	This parameter contains the sensor serial number.
SENSOR_TYPE	This parameter contains the index code for the sensor type described in the manufacturer's specific table. { 117, "Capacitance" }
SENSOR_UNIT	This parameter contains the engineering units index code for the calibration values. See Table 3.4.
SENSOR_VALUE	This parameter contains the raw sensor value. The uncalibrated measurement value from the sensor. Unit derives from SENSOR_UNIT.
TAB_ACTUAL_NUMBER	Contains the actual numbers of entries in the table. It shall be calculated after the transmission of the table is finished.
TAB_INDEX	The index parameter identifies which element of the table is in the X_VALUE and Y_VALUE parameter currently
TAB_MAX_NUMBER	TAB_MAX_NUMBER is the maximum size (number of X_VALUE and Y_VALUE values) of the table in the device.
TAB_OP_CODE	The modification of a table in a device influences the measurement or actuation algorithms of the device. Therefore an indication of a starting and an end point is necessary. The TAP_OP_CODE controls the transaction of the table. 0: not initialized 1: new operation characteristic, first value (TAB_ENTRY=1), old curve cleared 2: reserved 3: last value, end of transmission, check table, swaps the old curve with the new curve, actualize ACTUAL_NUMBER. 4: delete point of table with actual index (optional), sort records with increasing Charact-Input-Value, assign new indexes, and decrement CHARACT_NUMBER. 5: insert point (Charact-Input-Value relevant) (optional), sort records with increasing Charact-Input-Value, assign new indexes. Increment CHARACT_NUMBER. 6: replace point of table with actual index (optional).
TAB_STATUS	It is common to provide a plausibility check in the device. The result of this check is indicated in the TAB_STATUS parameter. 0: not initialized 1: good (new table is valid) 2: not monotonous increasing (old table is valid) 3: not monotonous decreasing (old table is valid) 4: not enough values transmitted (old table is valid) 5: too many values transmitted (old table is valid) 6: gradient of edge too high (old table is valid) 7: Values not excepted (old values are valid) 8 - 127 reserved > 128 manufacturer specific
TAB_X_Y_VALUE	The X_Y_VALUE parameter contains one value couple of the table.
TEMPERATURE	This parameter contains the temperature (e.g. sensor temperature used for measurement compensation) with the associated status used within the transducer. The unit of TEMPERATURE is the TEMPERATURE_UNIT.

Parameter	Description
TEMPERATURE_UNIT	This parameter contains the units of the temperature. The unit codes are: K (1000), °C (1001), and °F (1002).
TRD_TRANSDUCER_TYPE	Indicates the type of pressure transmitter: 108 , gauge; 65535 , others/special.
TRIMMED_VALUE	This parameter contains the sensor value after the trim processing. Unit derives from SENSOR_UNIT.
XD_ERROR	Indicates the condition of calibration process according to: {16, "Default value set"}, {22, "Applied process out of range"}, {26, "Invalid configuration for request"}, {27, "Excess correction"}, {28, "Calibration failed"}

Table 3.1 - Pressure Transducer Block Parameter Description

Pressure Transducer Block Parameter Attributes

Relative Index	Parameter Mnemonic	Object Type	Data Type	Store	Size	Access	Parameter usage/ Type of transport	Default -value	Down-load Order	Mandatory / Optional (Class)	View	
Standard Parameter											1	
Additional Parameter for Transducer Block												
8	SENSOR_VALUE	Simple	Float	D	4	r	C/a	0	-	M (B)		
9	SENSOR_HI_LIM	Simple	Float	N	4	r	C/a	0	-	M (B)		
10	SENSOR_LO_LIM	Simple	Float	N	4	r	C/a	0	-	M (B)		
11	CAL_POINT_HI	Simple	Float	N	4	raw	C/a	5080.0	-	M (B)		
12	CAL_POINT_LO	Simple	Float	N	4	raw	C/a	0.0	-	M (B)		
13	CAL_MIN_SPAN	Simple	Float	N	4	r	C/a	0	-	M (B)		
14	SENSOR_UNIT	Simple	Unsigned 16	N	2	raw	C/a	1151	2	M (B)		
15	TRIMMED_VALUE	Record	DS-33	D	5	r	C/a	0.0	-	M (B)		
16	SENSOR_TYPE	Simple	Unsigned 16	N	2	r	C/a	117	-	M (B)		
17	SENSOR_SERIAL_NUMBER	Simple	Unsigned 32	N	4	raw	C/a	0	-	M (B)		
18	PRIMARY_VALUE	Record	DS-33	D	5	r	C/a	0.0	-	M (B)	1	
19	PRIMARY_VALUE_UNIT	Simple	Unsigned 16	N	2	raw	C/a	1151	3	M (B)		
20	PRIMARY_VALUE_TYPE	Simple	Unsigned 16	N	2	raw	C/a	100	-	M (B)		
21	SENSOR_DIAPHRAGM_MATERIAL	Simple	Unsigned 16	S	2	raw	C/a	2	-	O (B)		
22	SENSOR_FILL_FLUID	Simple	Unsigned 16	S	2	raw	C/a	2	-	O (B)		
23	SENSOR_MAX_STATIC_PRESSURE	Not used.										
24	SENSOR_O_RING_MATERIAL	Not used.										
25	PROCESS_CONNECTION_TYPE	Not used.										
26	PROCESS_CONNECTION_MATERIAL	Not used.										
27	TEMPERATURE	Record	DS-33	D	5	r	C/a	0.0	-	O (B)		
28	TEMPERATURE_UNIT	Simple	Unsigned 16	N	2	raw	C/a	1001	4	O (B)		
29	SECONDARY_VALUE_1	Record	DS-33	D	5	r	C/a	0.0	-	O (B)		
30	SECONDARY_VALUE_1_UNIT	Simple	Unsigned 16	N	2	raw	C/a	1151	5	O (B)		
31	SECONDARY_VALUE_2	Record	DS-33	D	5	r	C/a	0	-	O (B)		
32	SECONDARY_VALUE_2_UNIT	Simple	Unsigned 16	N	2	raw	C/a	1151	6	O (B)		
33	LIN_TYPE	See explanation about table handling								1	M (B)	
34	SCALE_IN	Array	Float	S	8	raw	C/a	5080.0	7	O(B)		

Relative Index	Parameter Mnemonic	Object Type	Data Type	Store	Size	Access	Parameter usage/ Type of transport	Default -value	Down-load Order	Mandatory / Optional (Class)	View
35	SCALE_OUT	Array	Float	S	8	raw	C/a	0.0	8	O (B)	
36-37	Not Used										
38	TAB_ACTUAL_NUMBER	See explanation about table handling									
39	TAB_INDEX	See explanation about table handling									
40	TAB_MAX_NUMBER	See explanation about table handling									
41	TAB_MIN_NUMBER	See explanation about table handling									
42	TAB_OP_CODE	See explanation about table handling									
43	TAB_STATUS	See explanation about table handling									
44	TAB_X_Y_VALUE	See explanation about table handling									
45	MAX_SENSOR_VALUE	Simple	Float	N	4	raw	C/a	0.0	-	O (B)	
46	MIN_SENSOR_VALUE	Simple	Float	N	4	raw	C/a	0.0	-	O (B)	
47	MAX_TEMPERATURE	Simple	Float	N	4	raw	C/a	0.0	-	O (B)	
48	MIN_TEMPERATURE	Simple	Float	N	4	raw	C/a	0.0	-	O (B)	
49	RESERVED BY PNO										
50	RESERVED BY PNO										
51	RESERVED BY PNO										
52	RESERVED BY PNO										
53	RESERVED BY PNO										
54	RESERVED BY PNO										
55	RESERVED BY PNO										
56	RESERVED BY PNO										
57	RESERVED BY PNO										
58	RESERVED BY PNO										
59	RESERVED BY PNO										
60	CAL_TEMPERATURE	Simple	Float	N	4	raw	C/a	25.0	-	O (B)	
61	BACKUP_RESTORE	Simple	Unsigned 8	S	1	raw	C/a	0	-	O (B)	
62	FACTORY_CURVE_BYPASS	Simple	Unsigned 16	S	2	raw	C/a	0x0F	-	O (B)	
63	FACTORY_CURVE_X	Array	Float	S	20	raw	C/a	-	-	O (B)	
64	FACTORY_CURVE_Y	Array	Float	S	20	raw	C/a	-	-	O (B)	
65	FACTORY_CURVE_LENGTH	Simple	Unsigned 8	S	1	raw	C/a	5	-	O (B)	
66	PRESS_LIN_NORMAL	Record	DS-33	D	5	r	C/a	0.0	-	O (B)	
67	PRESS_NORMAL	Record	DS-33	D	5	r	C/a	0.0	-	O (B)	
68	DEAD BAND_BYPASS	Simple	Unsigned 8	S	1	raw	C/a	TRUE	-	O (B)	
69	COEFF_POL	Array	Float	S	48	raw	C/a	-	-	O (B)	
70	POLYNOMIAL_VERSION	Simple	Unsigned 8	S	1	raw	C/a	0x32	-	O (B)	
71	SENSOR_RANGE_CODE	Simple	Unsigned 8	S	1	raw	C/a	1	-	O (B)	
72	TRD_TRANSDUCER_TYPE	Simple	Unsigned 16	S	2	raw	C/a	107	-	O (B)	
73	XD_ERROR	Simple	Unsigned 8	D	1	r	C/a	0x10	-	O (B)	
74	MAIN_BOARD_SN	Simple	Unsigned 32	S	4	raw	C/a	0	-	O (B)	
75	EEPROM_FLAG	Simple	Unsigned 8	D	1	r	C/a	FALSE	-	O (B)	
76	ORDERING_CODE	Array	Unsigned 8	S	50	raw	C/a	-	-	O (B)	

Table 3.2 - Pressure Transducer Blocks Parameter Attributes

Cyclic Configuration

The PROFIBUS-DP and PROFIBUS-PA protocols have mechanisms against communication failures between the slave device and the network master. For example, during initialization, these mechanisms are used to check these possible errors. After powering up the field device (slave), it can cyclically exchange information with the class 1 master, if the parameterization for the slave is correct. This information is obtained using the GSD files (supplied by the device manufacturer, it contains their descriptions). Through the commands below, the master executes all initialization process with the PROFIBUS-PA device:

- **Get_Cfg:** uploads the slave configuration on the master and checks network configuration;
- **Set_Prm:** writes to the slave parameters and executes the parameterization network;
- **Set_Cfg:** configures the slaves according to its outputs and inputs;
- **Get_Cfg:** another command, where the master checks the slave configuration.

All these services are based on the information obtained from slave gsd files. The GSD file from **LD293** shows details such as, hardware and software revision, device bus timing and information about cyclic data exchange.

LD293 has 1 AI function block.

Most PROFIBUS configuration tools use two directories where the different manufacturers' GSD's and BITMAPS files are stored. The GSD's and BITMAPS for Smar devices can be obtained through the website: (<https://www.smar.com>), on the 'download' link.

The following example shows the necessary steps to integrate the **LD293** on a Profibus system. These steps are valid for the entire 303 line of Smar devices:

- Copy the **LD293** gsd file to the research directory of the PROFIBUS configuration tool, usually called GSD;
- Copy the **LD293** bitmap file to the research directory of the PROFIBUS configuration tool usually called BMP;
- After choosing the master, define the baud rate for the network. Do not forget that couplers may work with the following baud rate: 45.45 kbits/s (Siemens model), 93.75 kbits/s (P+F model) and 12 Mbits/s (P+F, SK2 model). The IM157 device link (Siemens model) may work up to 12 Mbits/s;
- Add the **LD293** and specify its physical bus address;
- Choose the cyclic configuration via parameterization using the gsd file that depends on the application, as detailed previously. For each AI (Analog Input) block, the **LD293** provides the process variable to the master in 5 bytes value, being the first four according to float point data type and the fifth byte is the status that brings the measure quality of this information.
- It allows activating the condition of watchdog, which the device goes to a fail safe condition, when a loss of communication is detected with the master.

How to Configure the Transducer Block

The transducer block has an algorithm, a set of contained parameters and a channel connecting it to a function block.

The algorithm describes the behavior of the transducer as a data transfer function between the I/O hardware and other function block. The set of contained parameters, it means, you are not able to link them to other blocks and publish the link via communication, defines the user interface to the transducer block. They can be divided into Standard and Manufacturer Specific.

The standard parameters will be present for such class of device, as pressure, temperature, actuator, etc., whatever is the manufacturer. Oppositely, the manufacturer's specific ones are defined only for its manufacturer. As common manufacturer specific parameters, we have calibration settings, material information, linearization curve, etc.

When you perform a standard routine as a calibration, you are conducted step by step by a method. The method is generally defined as guide line to help the user to make common tasks. The configuration tool identifies each method associated to the parameters and enables the interface to it.

The Profibus View and Simatic PDM (Process Device Manager) configuration software, for example, can configure many parameters of the Input Transducer block.

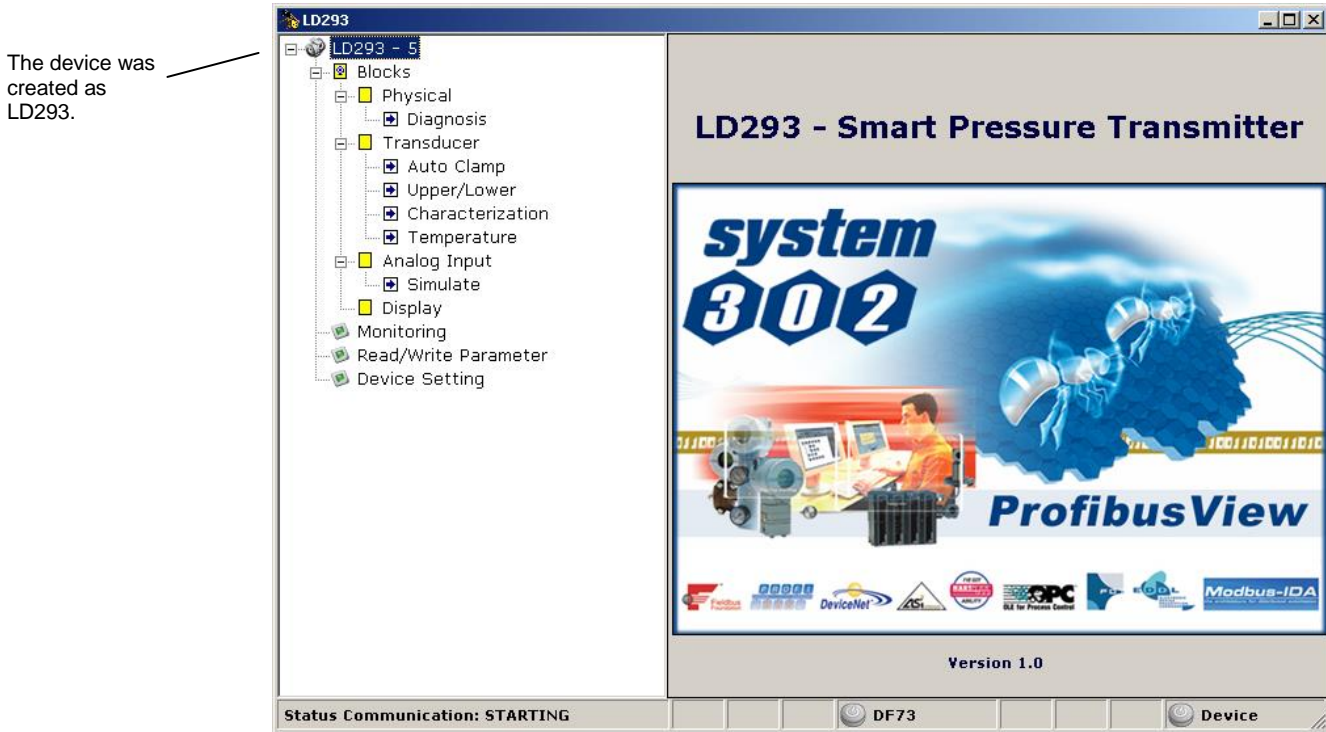

Figure 3.2 - Function and Transducers Blocks – Profibus View

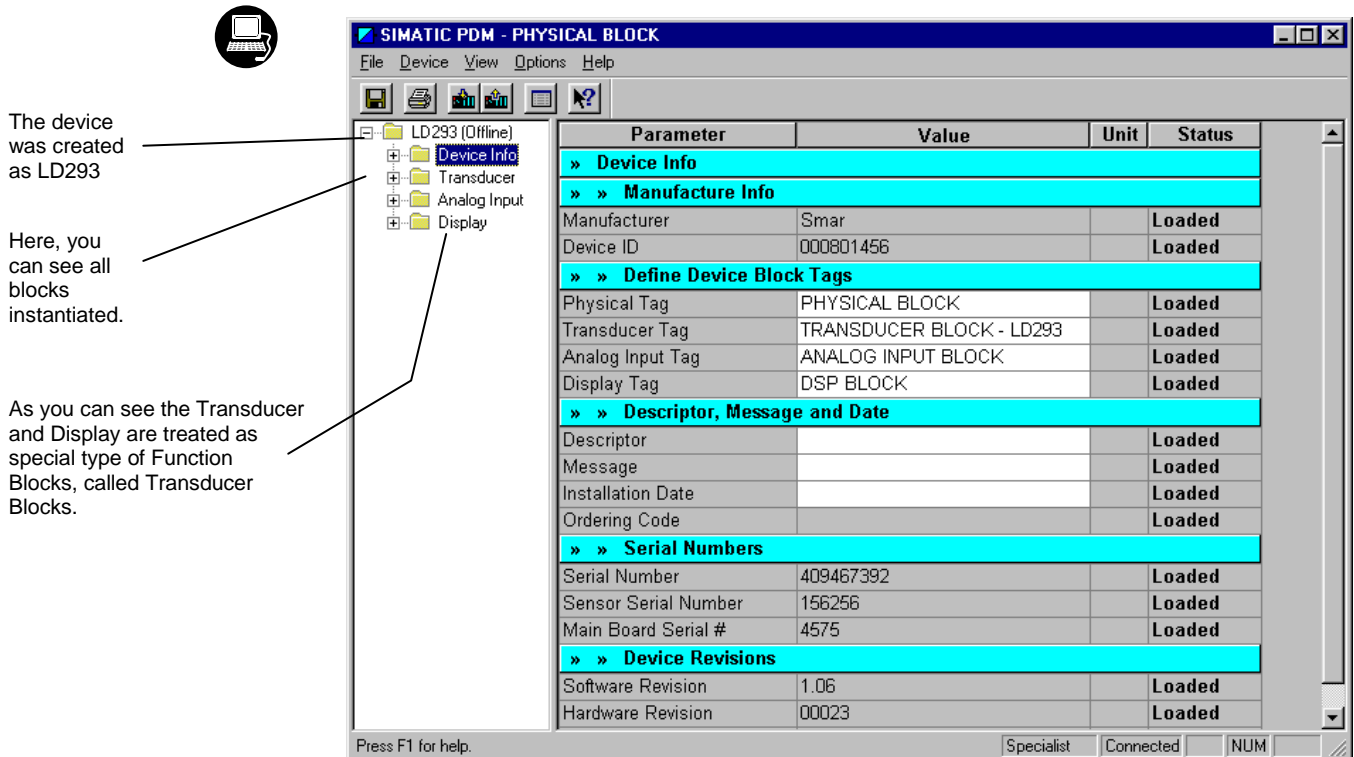

Figure 3.3 – Function and Transducers Blocks



To make the configuration of Transducer Block, we need to select "Device-Offline Configuration-Transducer" on the main menu:

Depending on the application, select "Pressure" or "Flow".

The user can select the linearization according to his application.

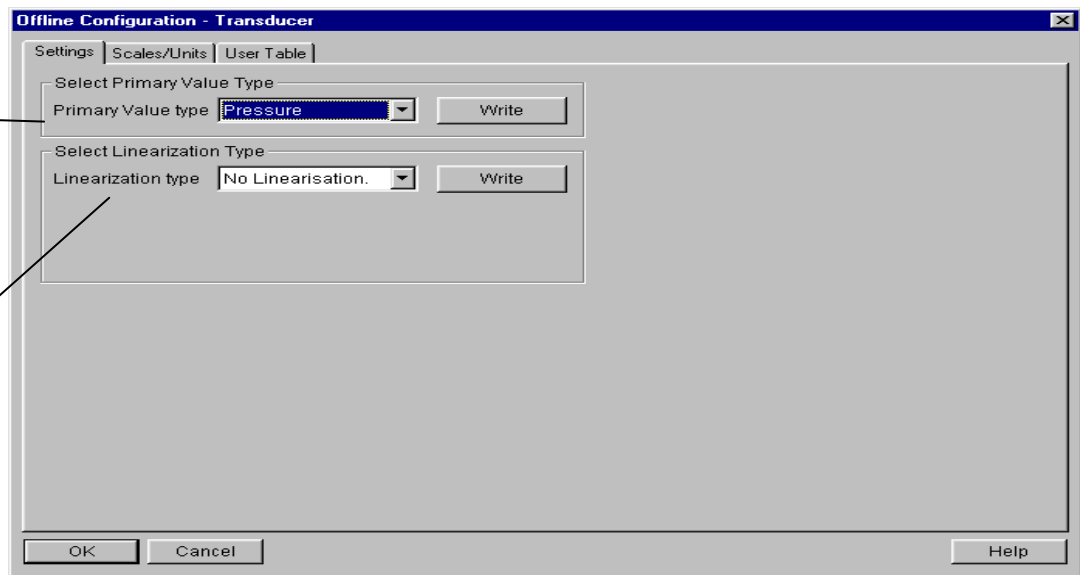

Figure 3.4 – Simatic PDM – Office Configuration – Transducer



Using the next window the user can configure the units according to the Transducer Block Diagram:

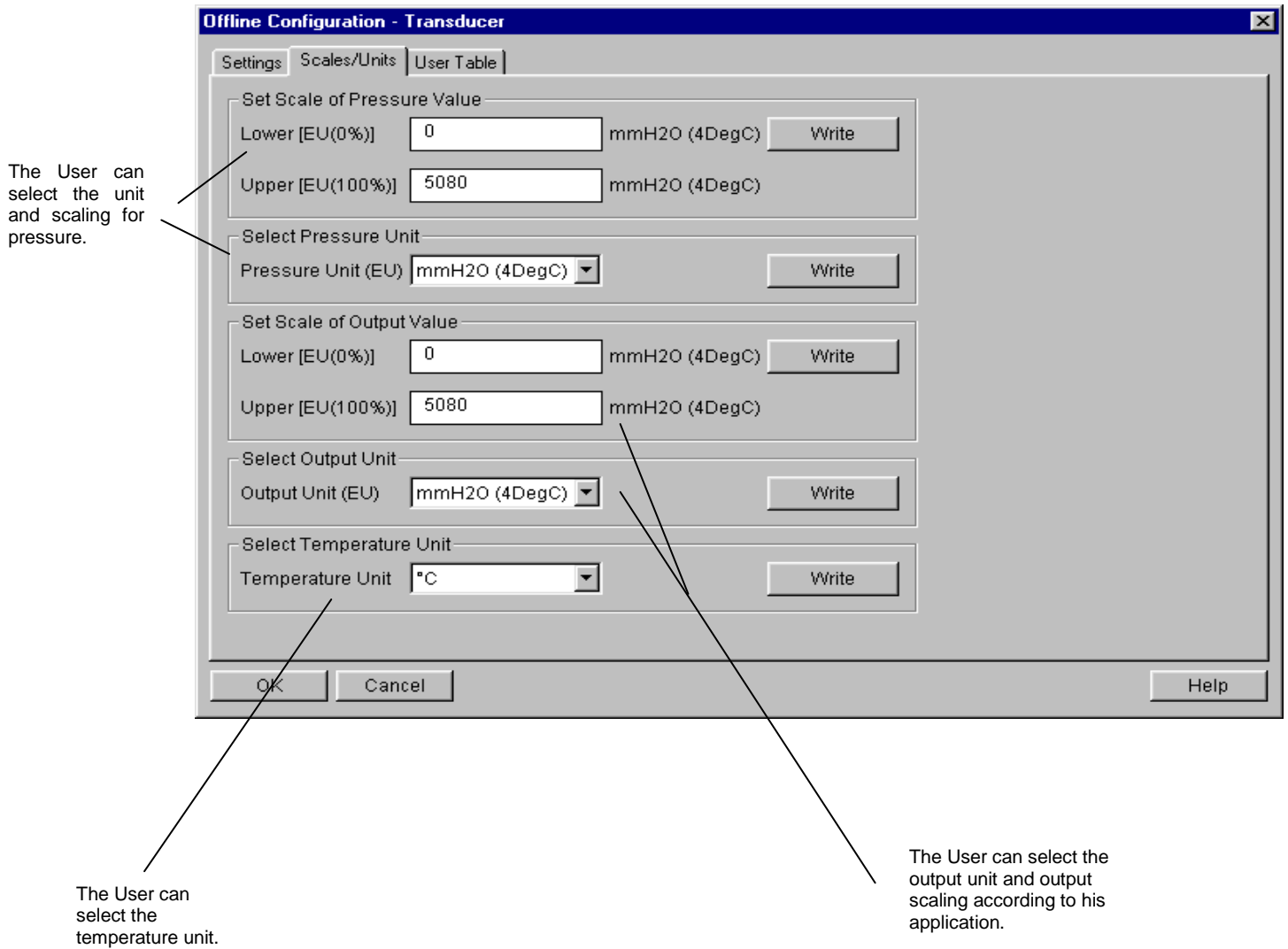

Figure 3.5 – Simatic PDM – Scale Units for Transducer Block

The user can select the user defined table selecting the correct linearization.



Table handling

There is the possibility to load and re-load tables in the devices. This table is used for linearization mostly. For this procedure the following parameters are necessary:

- TAB_INDEX
- TAB_X_Y_VALUE
- TAB_MIN_NUMBER
- TAB_MAX_NUMBER
- TAB_OP_CODE
- TAB_STATUS

The TAB_X_Y_VALUE parameter contains the value couple of the each table entries.

The TAB_INDEX parameter identifies which element of the table is in the TAB_X_Y_VALUE parameter currently (see the following figure).

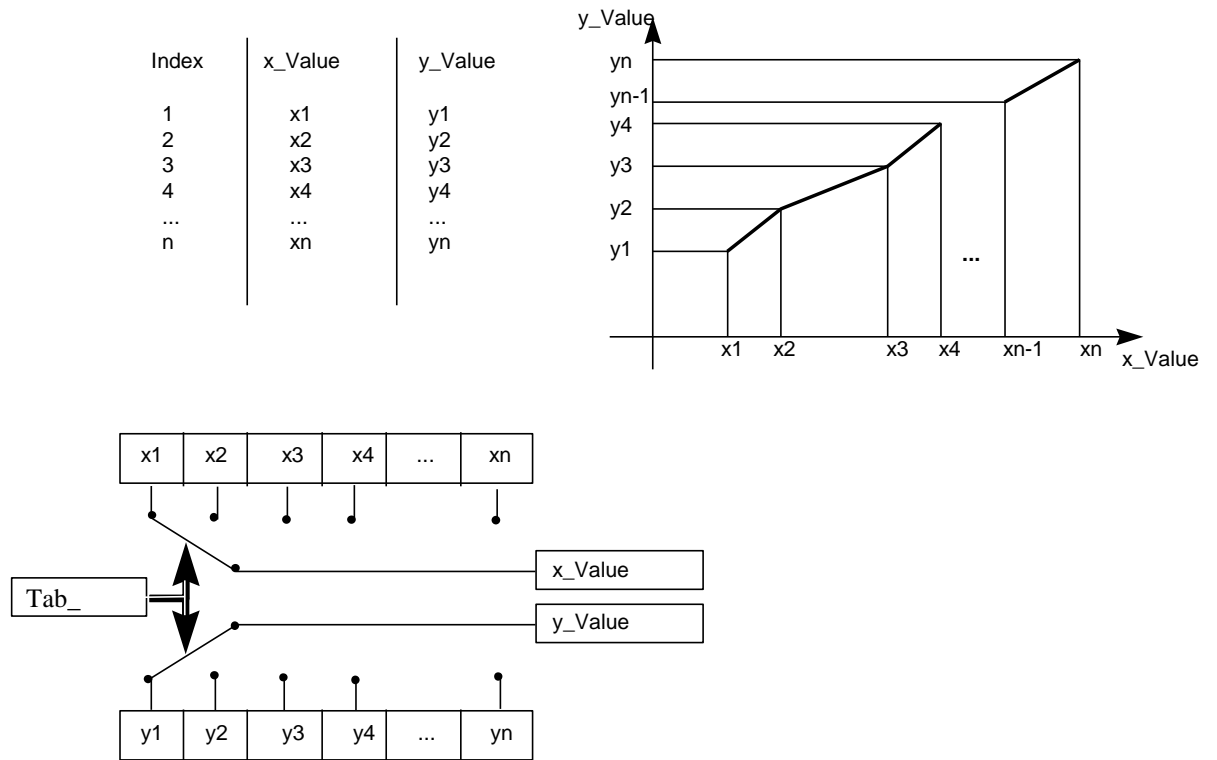

Figure 3.6 – Parameters of a Table

TAB_MAX_NUMBER is the maximum size of the table in the device. TAB_MIN_NUMBER is the minimum size of the table in the device.

The modification of a table in the device influences the measurement algorithms of the device. Therefore an indication of a starting and an endpoint is necessary. The TAB_OP_CODE controls the transaction of the table. The device provides a plausibility check. The result of this check is indicated in the TAB_STATUS parameter.

The User Table is used to make the pressure characterization in several points.

The user can configure up to 21 points in percentage unit.

The sensor characteristic curve at a certain temperature and for certain ranges may be slightly nonlinear.

This eventual non-linearity may be corrected through the User Table.

The user just needs to configure the input values and the correspondent output values in %.

Configure a minimum of two points. These points will define the characterization curve. The maximum number of points is 21. It is recommended to select the points equally distributed over the desired range or over a part of the range where more accuracy is required.

Go to "Device Off Line Configuration Transducer" window and select "user defined (table)".

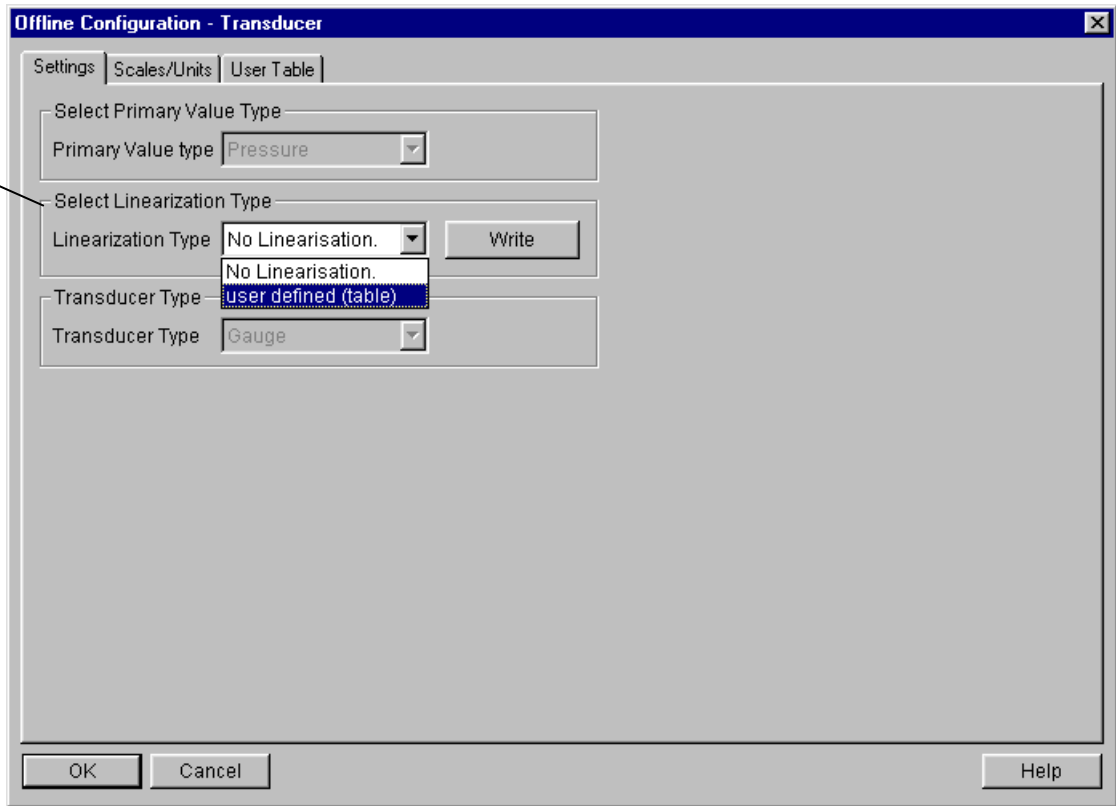

Figure 3.7 – LD293 Simatic PDM – Transducer Offline Configuration Screen

Using the menu Table, the user can configure the points.

The user also can read the configurable table and write a new one. In this case, the table must be monotonous increasing; otherwise, the points will not be configurable. Please see the following figure:

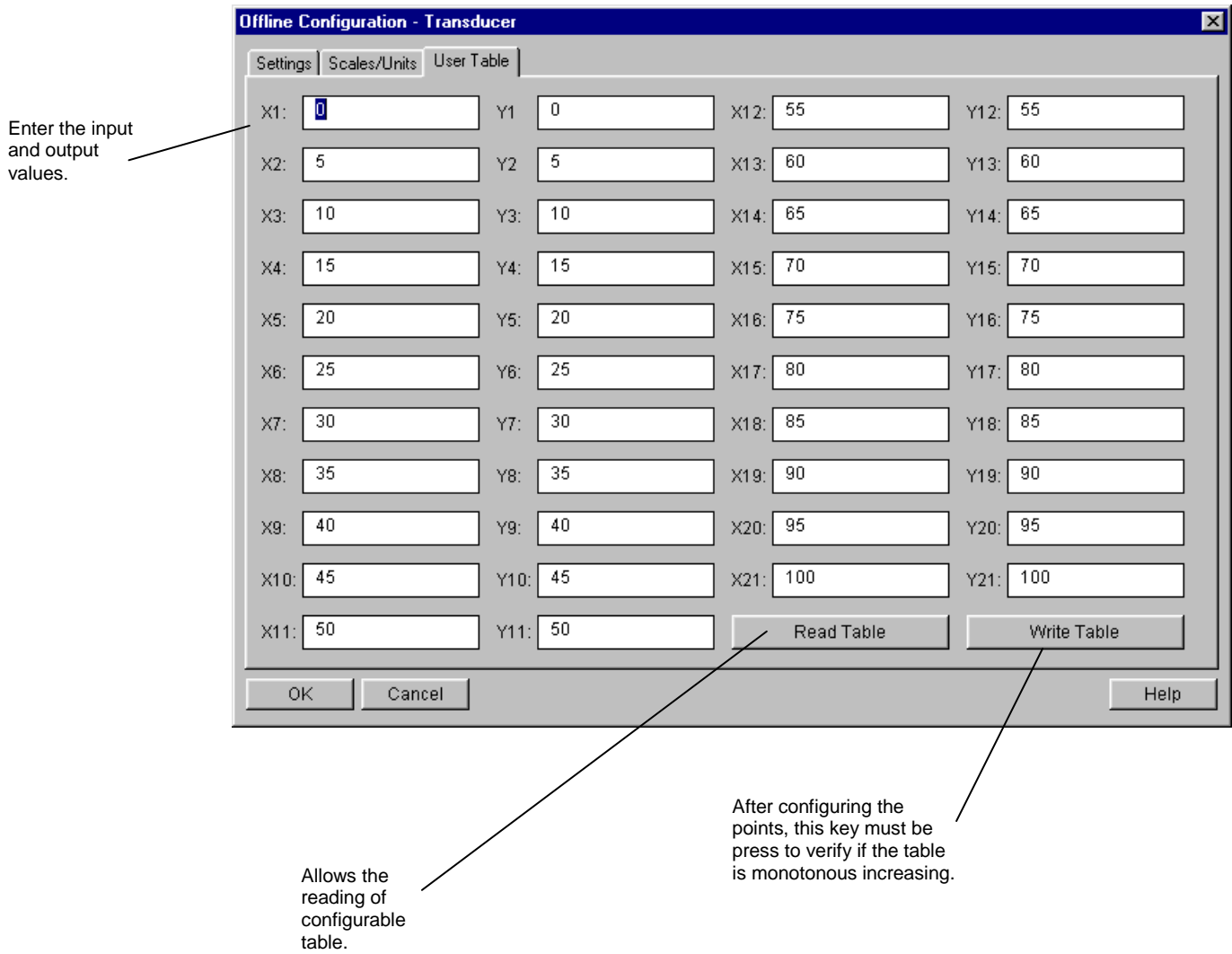



Figure 3.8 – LD293 Simatic PDM – Transducer Off Line Configuration – User Table Screen

See the Transducer Block configuration screens below using the Profibus View.

Settings | Scales / Units | User Table | Backup/Restore

Transducer Block



Primary Value Type
Primary Value Type: Pressure

Transducer Type
Transducer Type: Differential

Linearization Type
Linearization Type: No Linearisation

Write Help

Figure 3.9 - Scale Units for Transducer Block

Settings | Scales / Units | User Table | Backup/Restore

Transducer Block



Scale of Pressure Value
Lower [EU(0%)] : 0,000
Upper [EU(100%)] : 5080,000
Unit (EU) : mmH2O (68°F)

Scale of Output Value
Lower [EU(0%)] : 0,000
Upper [EU(100%)] : 5080,000
Unit (EU) : mmH2O (68°F)

Temperature Unit
Temperature Unit : °C

Write Help

Figure 3.10 - Transducer Configuration Screen

Settings | Scales / Units | **User Table** | Backup/Restore

Transducer Block

Nº Points: 21

X01:	0,000	Y01:	0,000	X08:	35,000	Y08:	35,000	X15:	70,000	Y15:	70,000
X02:	5,000	Y02:	5,000	X09:	40,000	Y09:	40,000	X16:	75,000	Y16:	75,000
X03:	10,000	Y03:	10,000	X10:	45,000	Y10:	45,000	X17:	80,000	Y17:	80,000
X04:	15,000	Y04:	15,000	X11:	50,000	Y11:	50,000	X18:	85,000	Y18:	85,000
X05:	20,000	Y05:	20,000	X12:	55,000	Y12:	55,000	X19:	90,000	Y19:	90,000
X06:	25,000	Y06:	25,000	X13:	60,000	Y13:	60,000	X20:	95,000	Y20:	95,000
X07:	30,000	Y07:	30,000	X14:	65,000	Y14:	65,000	X21:	100,00	Y21:	100,00

Write Help

Figure 3.11 - Transducer Configuration – User Table Screen

How to Configure the Analog Input Block



The Analog Input block takes the input data from the Transducer block, selected by channel number, and makes it available to other function blocks at its output. The transducer block provides the input unit of the Analog Input, and when the unit is changed in the transducer, the PV_SCALE unit is changed too. Optionally, a filter may be applied in the process value signal, whose time constant is PV_FTIME. Considering a step change to the input, this is the time in seconds to the PV reaches 63.2 % of the final value. If the PV_FTIME value is zero, the filter is disabled. For more details, please, see the Function Blocks Specifications.

To configure the Analog Input Block in offline mode, please, go to the main menu and select "Device Offline Configuration - Analog Input Block. Using this window, the user can configure the block mode operation, selects the channel, scales and unit for input and output value and the damping.

The user can set the block mode operation.

The user can select PV, Sec Value 1 or Sec Value 2 for the channel parameter.

Scale of input value. The unit comes from the transducer block.

Scales and unit for the output value.

The user can set the PV damping value.

The screenshot shows a software window titled "Offline Configuration - Analog Input" with three tabs: "Basic Settings", "Advanced Settings", and "Batch Info". The "Basic Settings" tab is active and contains several configuration sections:

- Select Block Mode:** A dropdown menu is set to "AUTO". A "Write" button is to the right.
- Select Input:** A dropdown menu is set to "PV". A "Write" button is to the right.
- Set Scale of Input Value:** Two rows of input fields. The first row has "Upper [EU(100%)]" set to "5080" and "mmH2O (68°F)". The second row has "Lower [EU(0%)]" set to "0" and "mmH2O (68°F)". A "Write" button is to the right of the second row.
- Set Scale of Output Value:** Two rows of input fields. The first row has "Upper [EU(100%)]" set to "5080". The second row has "Lower [EU(0%)]" set to "0". A "Write" button is to the right of the second row.
- Unit:** A dropdown menu is set to "mmH2O (68°F)".
- Set PV Damping Value:** An input field for "Damping" is set to "0" with a unit of "s". A "Write" button is to the right.

At the bottom of the window are three buttons: "OK", "Cancel", and "Help".

Figure 3.12 – Simatic PDM – Basic Settings for Analog Input Block

Selecting the page "Advanced Settings", the user can configure the conditions for alarms and warnings, as well the fail safe condition. Please, see the window:

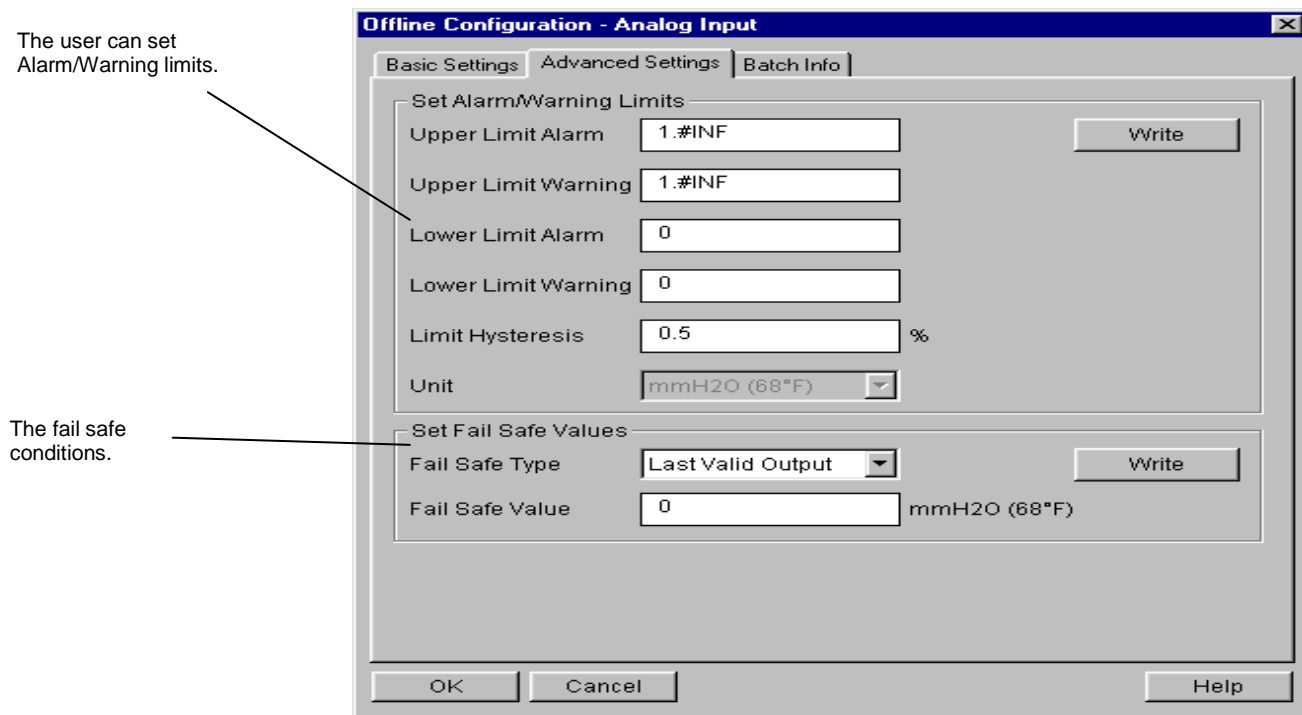

Figure 3.13 – Simatic PDM – Advanced Settings for Analog Input Block

In terms of online configuration for the Analog Input Block, please, go to the main menu and select "Device - Online Configuration - Analog Input - Block Mode":

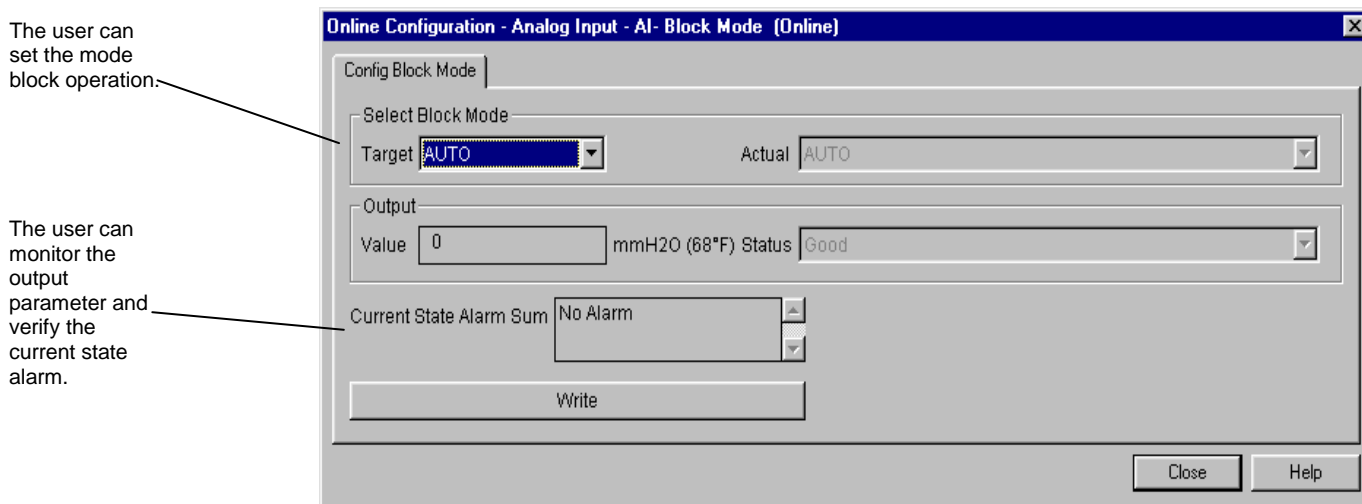

Figure 3.14 – Simatic PDM – Online Configuration for Analog Input Block

See the Analog Input Block configuration screens below using the Profibus View.

Basic Settings | **Advanced Settings** | Config Block Mode

Analog Input Block

Target: Channel:

Scale of Input Value

Upper [EU(100%)]
 Lower [EU(0%)]
 Unit:

Scale of Output Value

Upper [EU(100%)]
 Lower [EU(0%)]
 Unit:

Damping Value

Damping s

Figure 3.15 - Basic Settings for Analog Input Block

Basic Settings | **Advanced Settings** | Config Block Mode

Analog Input Block

Alarm/Warning Limits

Upper Limit Alarm
 Upper Limit Warning
 Lower Limit Alarm
 Lower Limit Warning
 Limit Hysteresis %
 Unit:

Fail Safe Values

Fail Safe Type
 Fail Safe Value

Figure 3.16 - Advanced Settings for Analog Input Block

Figure 3.17 - Configuration for Analog Input Block

Lower and Upper Trim

NOTE

The calibration screens of lower and upper value of the Profibus View are similar to Simatic PDM screens.

Each sensor has a characteristic curve that establishes a relation between the applied pressure and the sensor signal. This curve is determined for each sensor and it is stored in a memory together with the sensor. When the sensor is connected to the transmitter circuit, the content of its memory is made available to the microprocessor.

Sometimes the value on the transmitter display and transducer block reading may not match the applied pressure.

NOTE

Check on section 1, the note on the influence of the mounting position on the indicator. For better accuracy, the trim adjustment should be made in the in the lower and upper values of the operation range values.

The reasons may be:

- The transmitter mounting position.
- The user's pressure standard differs from the factory standard.
- The transmitter had its original characterization shifted by over pressurization, over heating or by long term drift.

The **TRIM** is used to match the reading with the applied pressure.

There are two types of trim available:

Lower Trim: It is used to trim the reading at the lower range. The operator informs the **LD293** the correct reading for the applied pressure. The most common discrepancy is the lower reading.

Upper Trim: It is used to trim the reading at the upper range. The operator informs the correct reading to **LD293** for the applied pressure.

For best accuracy, trim should be done at the operating range.

The figures 3.18 to 3.21 show the trim adjustment operation into Simatic PDM.

Pressure Trim - LD293

NOTE

The calibration screens Pressure Trim of the Profibus View are similar to Simatic PDM screens.



Via Simatic PDM

It is possible to calibrate the transmitter by means of parameters CAL_POINT_LO and CAL_POINT_HI.

First of all, a convenient engineering unit should be chosen before starting the calibration. This engineering unit is configured by SENSOR_UNIT parameter. After its configuration the parameters related to calibration will be converted to this unit. Then, select Zero/Lower or Upper calibration menu.

The parameter SENSOR_UNIT should be configured according to the Engineering Unit wished for calibrating the device.

After the selection, this key should be pressed to complete the operation

The Engineering Units can be chosen from the Sensor Units list box.

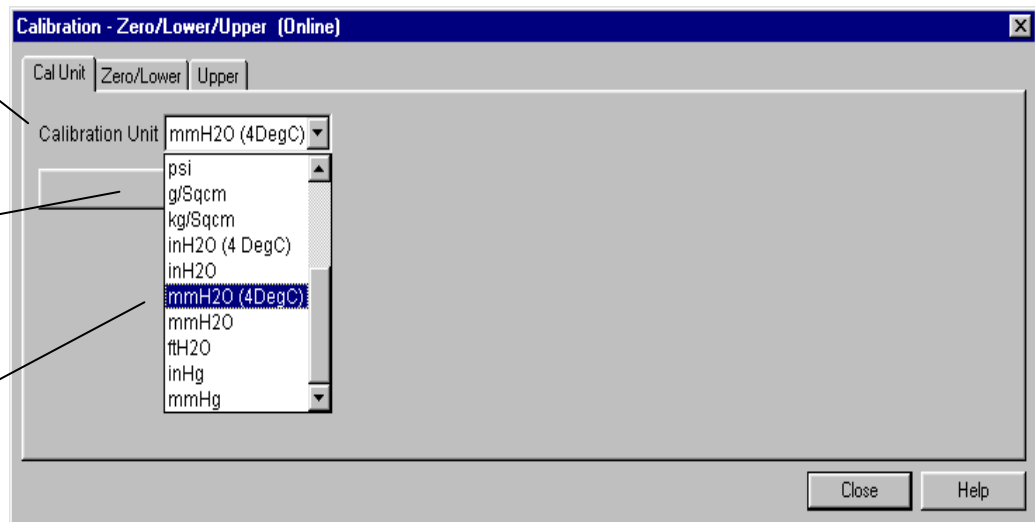

Figure 3.18 – LD293 Simatic PDM – Transducer Configuration Screen

The following engineering unit's codes are defined for pressure according to Profibus PA standard:

UNIT	CODES
InH ₂ O a 68 °F	1148
InHg a 0 °C	1156
ftH ₂ O a 68 °F	1154
mmH ₂ O a 68 °F	1151
mmHg a 0 °C	1158
psi	1141
bar	1137
mbar	1138
g/cm ²	1144
k/cm ²	1145
Pa	1130
kPa	1133
torr	1139
atm	1140
Mpa	1132
inH ₂ O a 4 °C	1147
mmH ₂ O a 4 °C	1150

Table 3.4 – Engineering Unit’s Code



SENSOR_UNIT allows the user to select different units for calibration purposes than the units defined by SENSOR_RANGE. The SENSOR_HI_LIM and SENSOR_LO_LIM parameters define the maximum and minimum values the sensor is capable of indicating, the engineering units used, and the decimal point.

Let’s take the lower value as an example:

Apply to the input zero or the pressure lower value in an engineering unit, this being the same used in parameter SENSOR_UNIT, and wait until the readout of pressure stabilizes.

Write zero or the lower value in parameter CAL_POINT_LO. For each value written a calibration is performed at the desired point.

For this case, a sensor range 3 is used: the LRL is 0 mmH2O

The Lower Calibration Point should be entered. This value must be inside of the Sensor range limits allowed for each type of sensor.

After the calibration, the user can see the result for this process.

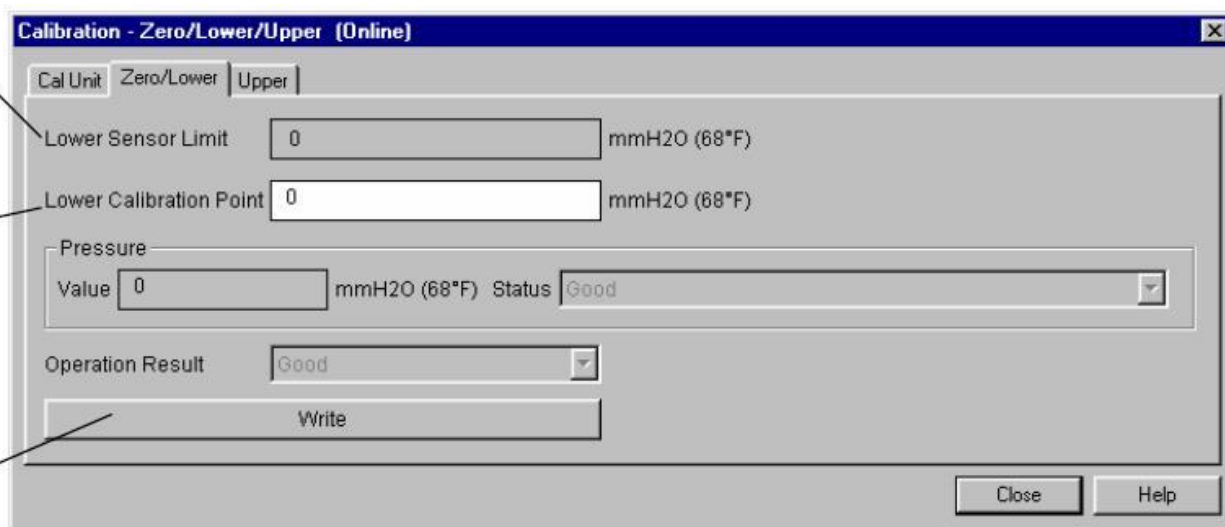

Figure 3.19 – LD293 Simatic PDM – Transducer Configuration Screen



Let’s take the upper value as an example:

Apply to the input as the upper value a pressure of 25.400 mmH₂O and wait until the readout of pressure stabilizes. Then, write the upper value as, for example, 25.400 mmH₂O in parameter CAL_POINT_HI. For each value written a calibration is performed at the desired point.

For this case, a sensor range 3 is used: The URL is 25400 mmH2O or 1000 inH2O.

The Upper Calibration Point should be entered. This value must be inside of the Sensor range limits allowed for each type of sensor.

After the calibration, the user can see the result for this process.

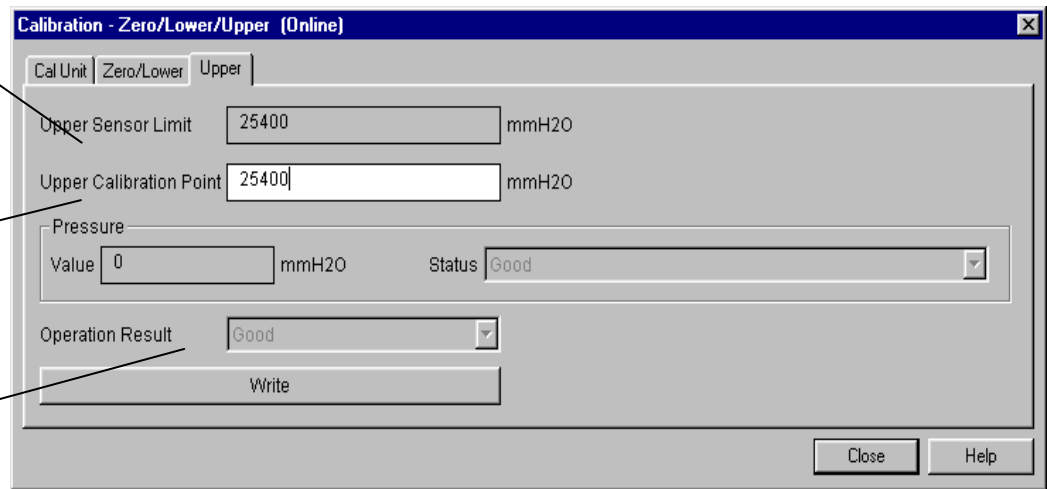

Figure 3.20 – LD293 Simatic PDM – Transducer Configuration Screen

WARNING

It is recommendable, for every new calibration, to save existing trim data, by means of parameter BACKUP_RESTORE, using option "Last Cal Backup".

Via Local Adjustment

In order to enter the local adjustment mode, place the magnetic tool in office “Z” until flag “MD” lights up in the display. Remove the magnetic tool from “Z” and place it in orifice “S”. Remove and reinsert the magnetic tool in “S” until the message “LOC ADJ” is displayed. The message will be displayed during approximately 5 seconds after the user removes the magnetic tool from “S”. Let’s take the upper value as an example:

Apply to the input a pressure of 25.400 mmH₂O.
Wait until the pressure value stabilizes and then actuates parameter UPPER until it reads 25.400.

For the lower value the procedure is the same, but we need to actuate in the parameter LOWER.

NOTE

Trim mode exit via local adjustment occurs automatically should the magnetic tool not be used during some seconds.

Keep in that even when parameters LOWER or UPPER already present the desired value, they must be actuated so that calibration is performed.

Limit Conditions for Calibration:

For every writing operation in the transducer blocks there is an indication for the operation associate with the waiting method. These codes appear in parameter XD_ERROR. Every time a calibration is performed. Code 16, for example, indicates a successfully performed operation.

Upper:

$SENSOR_RANGE_EU0 < NEW_UPPER < SENSOR_RANGE_EU100 * 1.25$
Otherwise, XD_ERROR = 26.
 $(NEW_UPPER - PRIMARY_VALUE) < SENSOR_RANGE_EU100 * 0.1$
Otherwise, XD_ERROR = 27.
 $(NEW_UPPER - CAL_POINT_LO) > CAL_MIN_SPAN * 0,75$
Otherwise, XD_ERROR = 26.

NOTE

Codes for XD_ERROR:

- 16:** Default Value Set
- 22:** Out of Range.
- 26:** Invalid Calibration Request.
- 27:** Excessive Correction.

Characterization Trim

NOTE

The calibration screens Characterization Trim of the Profibus View are similar to Simatic PDM screens.

It is used to correct the sensor reading in several points.

Use an accurate and stable pressure source, preferably a dead-weight tester, to guarantee the accuracy must be at least three times better than the transmitter accuracy. Wait for the pressure to stabilize before performing trim.

The sensor characteristic curve at a certain temperature and for certain ranges may be slightly nonlinear. This eventual non-linearity may be corrected through the Characterization Trim.

The user may characterize the transmitter throughout the operating range, obtaining even better accuracy.

The characterization is determined from two up to five points. Just apply the pressure and tell the transmitter the pressure that is being applied.

WARNING

The characterization trim changes the transmitter characteristics. Read the instructions carefully and certify that a pressure standard with accuracy 0.03% or better is being used, otherwise the transmitter accuracy will be seriously affected.

Characterize a minimum of two points. These points will define the characterization curve. The maximum number of points is five. It is recommended to select the points equally distributed over the desired range or over a part of the range where more accuracy is required.

The Figure 3.21 shows the window of Simatic PDM to characterize a new curve. Note that FACTORY_CURVE_X indicates the applied pressure according to standard pressure source and FACTORY_CURVE_Y indicates measured pressure value to **LD293**.

The number of points is configured in parameter FACTORY_CURVE_LENGTH, being in the maximum 5 points. The entry points will be configured in the FACTORY_CURVE_X and of output in the FACTORY_CURVE_Y.

The Parameter FACTORY_CURVE_BYPASS controls the enabling/disabling of the curve and has the following options:

- "Disable ",
- "Enable and Backup Cal " ,
- "Disable and Restore Cal " ,
- "Disable or Allows to enter the points"



To configure the points of the curve, the option "**Disable or allows entering the points**" must be chosen. Then press the "Characterization Cal". The following message appears: "This Function alters XMTR characteristics. Proceed? Y/N". To proceed, select "Yes". A new message appears: "Is XMTR connected to accurate pressure standard?". To proceed, select "Yes". Apply the desired pressure and wait that the same one stabilizes. If the pressure is not stable, select "No-read again". If it is stable, enter "Yes" and then, type the applied pressure P1. Repeat this procedure for the next point P2. After that, if the user wants to configure more points, just repeat this procedure up to 5 points. If not, just select "No" for the question "Do you want to configure more points?".

After configuring the points, the user needs to qualify the curve. The option "Enable and backup cal", enables the curve and save the calibration settings. The option "Disable and restore the cal", disables the curve and restores the calibration settings. The option "Disable", just disables the curve and does not take care about the calibration settings.

By the list box the user can enable or disable the Characterization Curve, enter the points, restore or backup the curve entered.

After choosing the condition for the curve, please, press this key to initiate the characterization curve method.

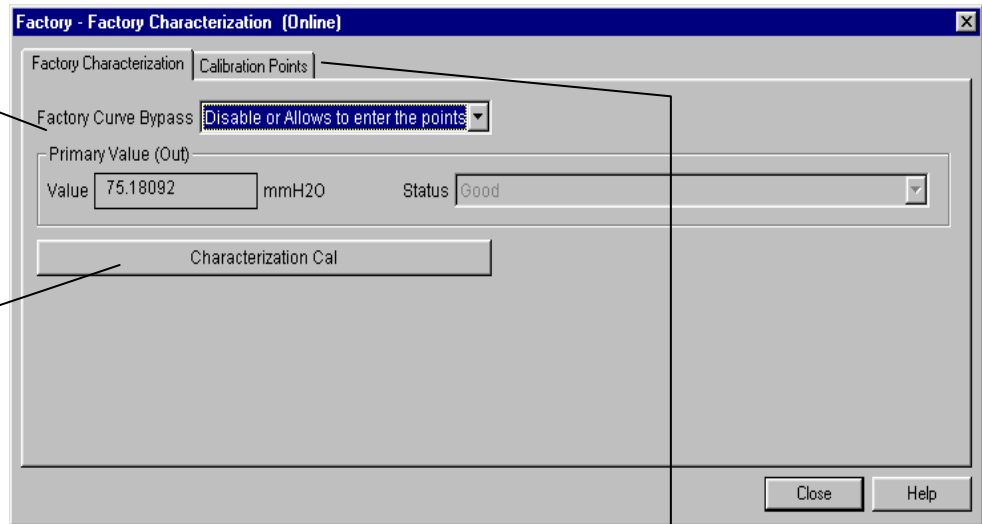

Select this page to see the configured points.

Figure 3.21 – The Characterization Curve Configuration

The Characterization Curve can have a minimum of 2 and up to 5 points. These points should be between the calibrated range for better results.

Sensor Information



The main information about the transmitter can be accessed selecting the Transducer block folder option as shown on the next figure. The sensor information will be displayed as shown below.

Sensor Construction Information.

Parameter	Value	Unit	Status
» Transducer			
» » Select Primary Value Type			
Primary Value type	Pressure		Loaded
» » Select Linearization Type			
Linearization type	No Linearisation.		Loaded
» » Set Scale of Pressure Value			
Lower [EU(0%)]	0	mmH2	Loaded
Upper [EU(100%)]	5080	mmH2	Loaded
» » Select Pressure Unit (EU)			
Pressure Unit (EU)	mmH2O		Loaded
» » Set Scale of Output Value			
Lower [EU(0%)]	0	mmH2	Loaded
Upper [EU(100%)]	5080	mmH2	Loaded
» » Select Output Unit			
Output Unit (EU)	mmH2O		Loaded
» » See Sensor Construction Info			
Sensor Type	Capacitance		Loaded
Sensor Range Code	Range 3 (1000 inH2O)		Loaded
Module Fill Fluid	Inert		Loaded
Isolator Material	Ox8		Loaded

Figure 3.22 – Simatic PDM Transducer Block – Sensor Information

Some parameters are only factory configured (e.g. Sensor Type, Module Fill Fluid, etc.).

Temperature Trim

NOTE
The calibration screens Temperature Trim the Profibus View are similar to Simatic PDM screens.



Write in parameter CAL_TEMPERATURE any value in the range -40°C to +85°C. After that, check the calibration performance using parameter TEMPERATURE. The user can select the unit using the parameter TEMPERATURE_UNIT. Normally, its operation is done by a method in the factory.

The user can select the temperature unit.

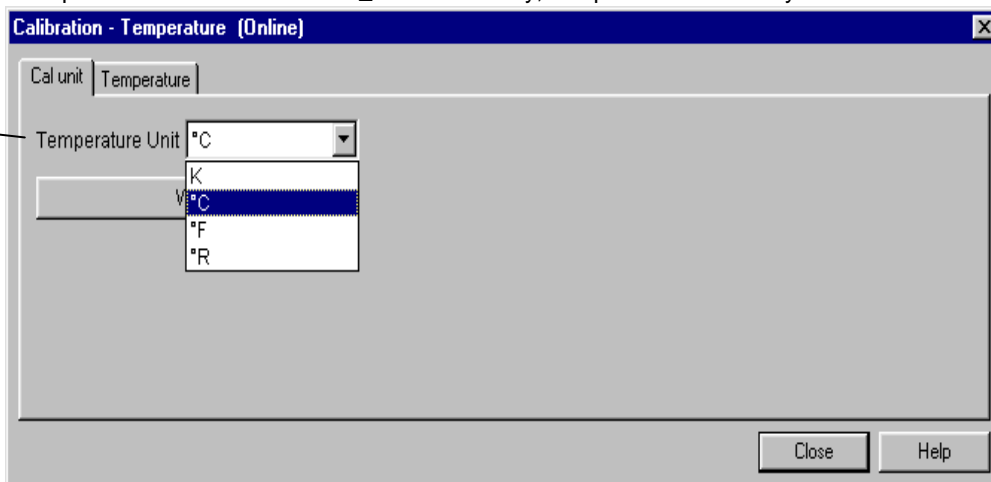

Figure 3.23 – The Temperature Screen

The window shows the actual calibrated point and allows entering the desired new point.

By adjusting this parameter to the current temperature, the device's temperature indication is adjusted.

The result of temperature calibration process.

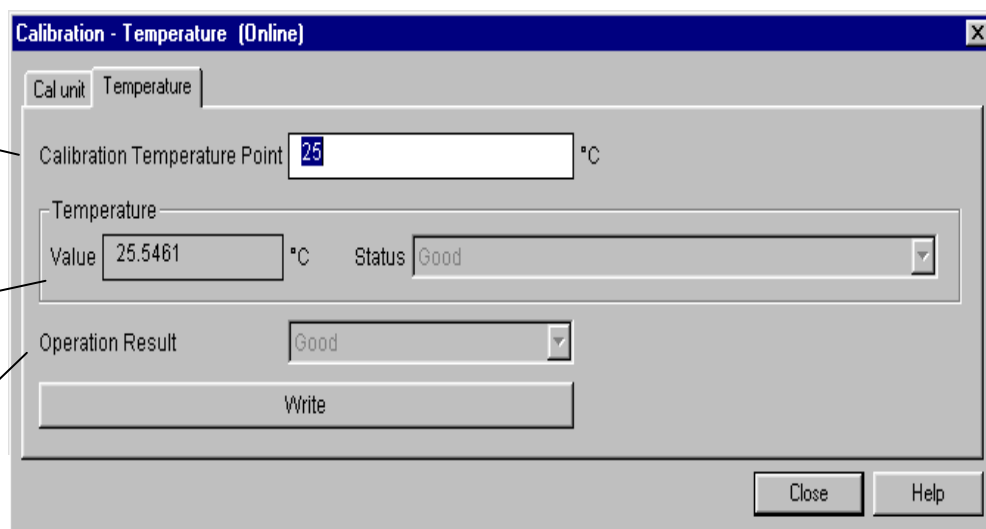

Figure 3.24 – The Temperature Trim Configuration Screen

Sensor Data Reading



All time that transmitter **LD293** is on, is verified if the serial number of the sensor in the sensor board is the same that the recorded serial number in E2PROM in the main board. When these numbers are different (a swap of sensor set or main board was carried through) the data stored in the E2PROM of sensor board is copied to the E2PROM of the main board.

Through the parameter **BACKUP_RESTORE**, also this reading can be made, choosing the option "Sensor Data Restore". The operation, in this case, is made independent of the sensor serial number. Through the option "Sensor Data Backup", the sensor data stored in the main board EPROM memory can be saved in the E2PROM of the sensor board. (This operation is done at factory).

Through this parameter, we can recover default data from factory about sensor and last saved calibration settings, as well as making the rescue of calibrations. We have the following options:

- **Factory Cal Restore:** Recover last calibration settings made at factory;
- **Last Cal Restore:** Recover last calibration settings made by user and saved as backup;
- **Default Data Restore:** Restore all data as default;
- **Sensor Data Restore:** Restore sensor data saved in the sensor board and copy them to main board EPROM memory.
- **Factory Cal Backup:** Copy the actual calibration settings to the factory ones;
- **Last Cal Backup:** Copy the actual calibration settings to the backup ones;
- **Sensor Data Backup:** Copy the sensor data at main board EPROM memory to the EPROM memory located at the sensor board;
- **None:** Default value, no action is done.

On the main menu, selecting "**Device Factory - Backup/Restore**", the user can select backup and restore operations:

NOTE

The backup setting screen of the Profibus View is similar to Simatic PDM screen.

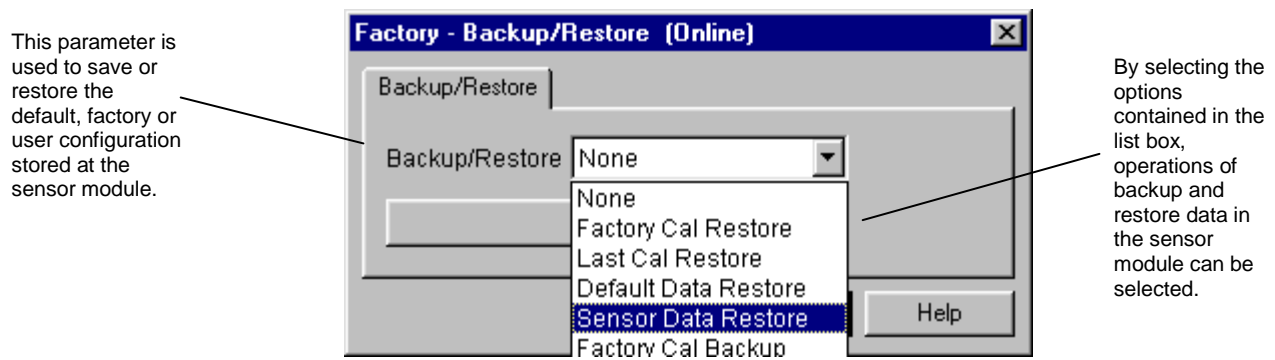

Figure 3.25 – Transducer Block – Backup/Restore

Transducer Display – Configuration

NOTE

The calibration screens Transducer Display of the Profibus View are similar to Simatic PDM screens.

Using the Profibus View or Simatic PDM or any other configuration tool is possible to configure the Display Transducer block. As the name described it is a transducer due the interfacing of its block with the LCD hardware.

The Transducer Display is treated as a normal block by **any configuration tool**. It means, this block has some parameters and those ones can be configured according to customer's needs.

The customer can choose up to six parameters to be shown at LCD display; they can be parameters just for monitoring purpose or for acting locally in the field devices by using a magnetic tool. The seventh parameter is used to access the physical device address. The user can change this address according to his application. To access and configure the Display Block, please, go to the main menu; select "Device OnLine Configuration - Display Block":

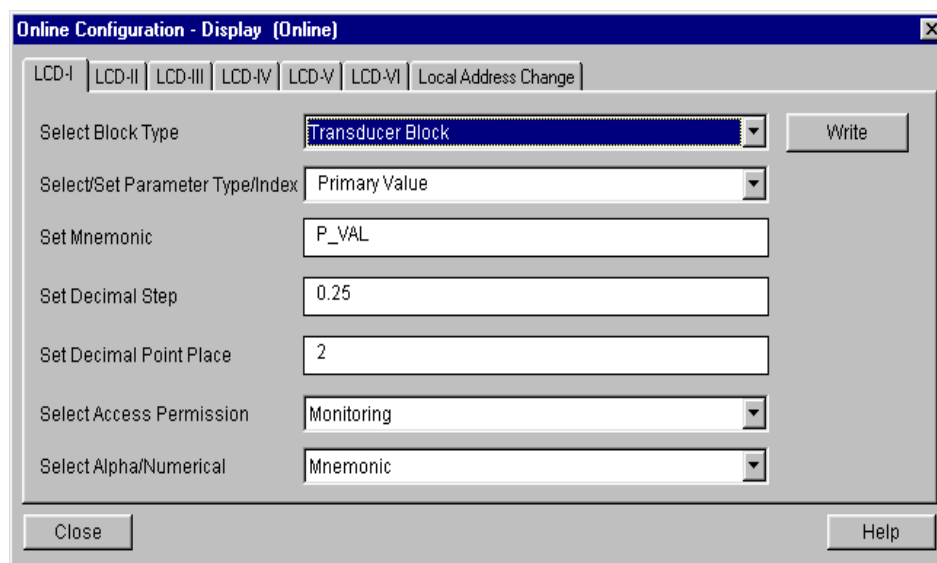

Figure 3.26 – Display Block and Simatic PDM

Display Transducer Block

The local adjustment is completely configured by Profibus View or Simatic PDM or any configuration tool. It means, the user can select the best options to fit his application. From factory, it is configured with the options to set the Upper and Lower trim, for monitoring the input transducer output and check the Tag. Normally, the transmitter is much better configured by Profibus View or Simatic PDM or configuration tool, but the local functionality of the LCD permits an easy and fast action on certain parameters, since it does not rely on communication and network wiring connections. Among the possibilities by Local Adjustment, the following options can be emphasized: Mode block, Outputs monitoring, Tag visualization and Tuning Parameters setting.

The interface between the user is described very detailed on the "*General Installation, Operation and Maintenance Procedures Manual*". Please take a detailed look at this manual in the chapter related to "*Programming Using Local Adjustment*". It is significantly the resources on this transducer display, also all the **Series 303** field devices from SMAR has the same methodology to handle with it. So, since the user has learned once, he is capable to handle all kind of field devices from SMAR.

All function block and transducers defined according Profibus PA have a description of their features written by the Device Description Language.

This feature permits that third party configuration tools enabled by Device Description Service technology can interpret these features and make them accessible to configure. The Function Blocks and Transducers of Series 303 have been defined rigorously according the Profibus PA specifications in order to be interoperable to other parties.

In order to able the local adjustment using the magnetic tool, it is necessary to previously prepare the parameters related with this operation via System Configuration.

There are six groups of parameters, which may be pre-configured by the user in order to able, a possible configuration by means of the local adjustment. As an example, let's suppose that you don't want to show some parameters; in this case, simply select "None" in the parameter, "Select Block Type". Doing this, the device will not take the parameters related (indexed) to its Block as a valid parameter.

Definition of Parameters and Values

Select Block Type

This is the type of the block where the parameter is located. The user can choose: Transducer Block, Analog Input Block, Physical Block or None.

Select/Set Parameter Type/Index

This is the index related to the parameter to be actuated or viewed (0, 1, 2...). For each block there are some pre-defined indexes. Refer to the Function Blocks Manual to know the desired indexes and then just enter the desired index.

Set Mnemonic

This is the mnemonic for the parameter identification (it accepts a maximum of 16 characters in the alphanumeric field of the display). Choose the mnemonic, preferably with no more than 5 characters because, this way, it will not be necessary to rotate it on the display.

Set Decimal Step

It is the increment and decrement in decimal units when the parameter is Float or Float Status value, or integer, when the parameter is in whole units.

Set Decimal Point Place.

This is the number of digits after the decimal point (0 to 3 decimal digits).

Set Access Permission

The access allows the user to read, in the case of the "Monitoring" option, and to write when "action" option is selected, then the display will show the increment and decrement arrows.

Set Alpha Numerical

These parameters include two options: value and mnemonic. In option value, it is possible to display data both in the alphanumeric and in the numeric fields; this way, in the case of a data higher than 10000, it will be shown in the alphanumeric field. It is useful when we are showing totalization at the LCD interface.

In option mnemonic, the display may show the data in the numeric field and the mnemonic in the alphanumeric field.

NOTE

For devices where the software version is higher or equal to 1.10, please see the configuration of local adjustment using the local adjustment, in the Installation, operation and maintenance procedures manual.



In case you wish to visualize a certain tag, opt for the index relative equal to "tag". To configure other parameters just select "LCD-II" up to "LCD-VI" windows:

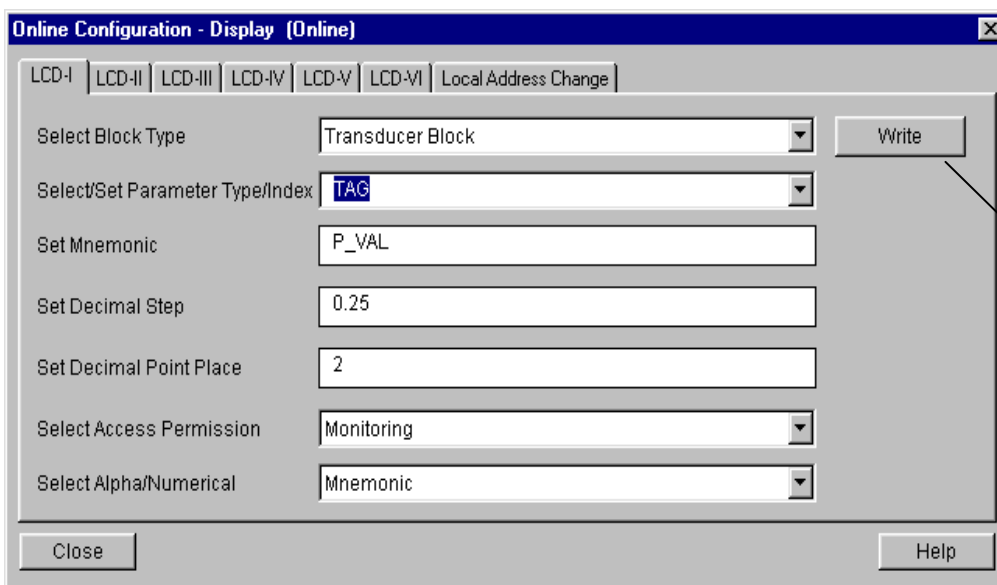

The option "Write" should be selected in order to execute the upgrade of local adjustment programming tree. After its step all the selected parameters will be shown on the LCD display.

Figure 3.27 – Parameters for Local Adjustment Configuration



The window "Local Address Change" allows the user "enable/disable" the access to changing the physical device address.

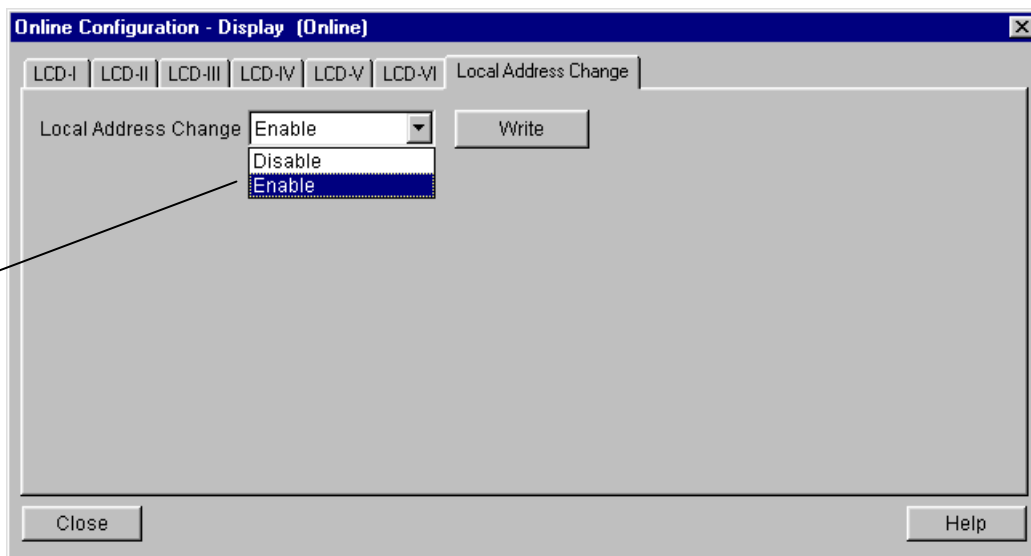

When the option "enable" is selected, the user can change the physical device address.

Figure 3.28 – Parameters for Local Adjustment Configuration

When the user enter into the local adjustment and rotate the parameters using the magnetic tool, after escaping to normal operation, e.g., the monitoring, if the parameter when the magnetic tool is removed has "Access Permission equal to "monitoring", then this last parameter will be shown at the LCD.

Always on the LCD interface will be shown two parameters at the same time, switching between the configured parameter at the LCD-II and the last monitoring parameter. If the user do not want to show two parameters at the same time, it is only necessary to opt for "none" when configure the LCD-II:

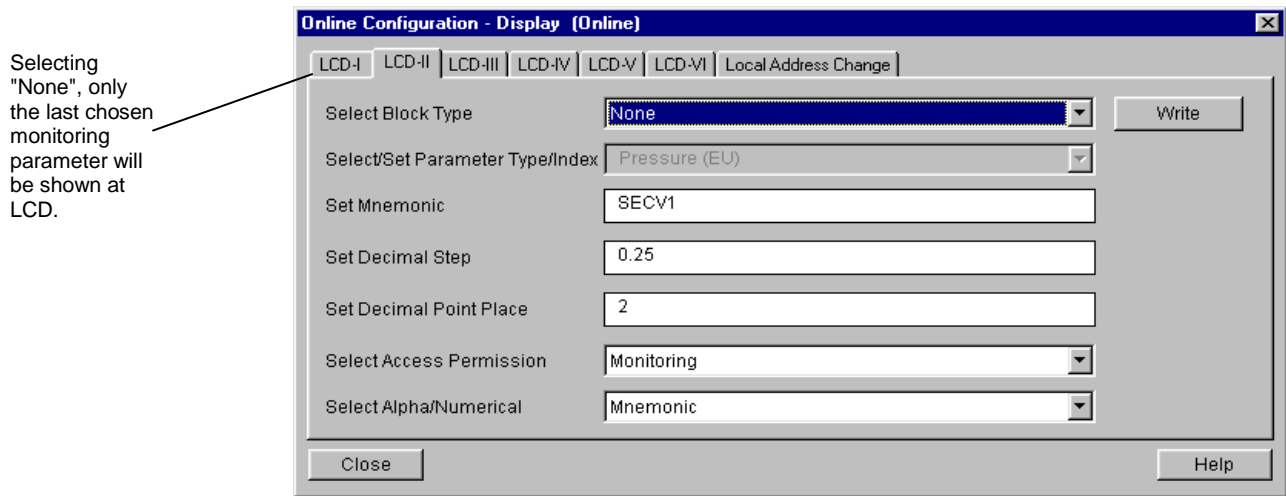

Figure 3.29 Parameters for Local Adjustment Configuration



The user can select the "Mode Block" parameter at the LCD. In this case is necessary to select the index equal to "Mode Block":

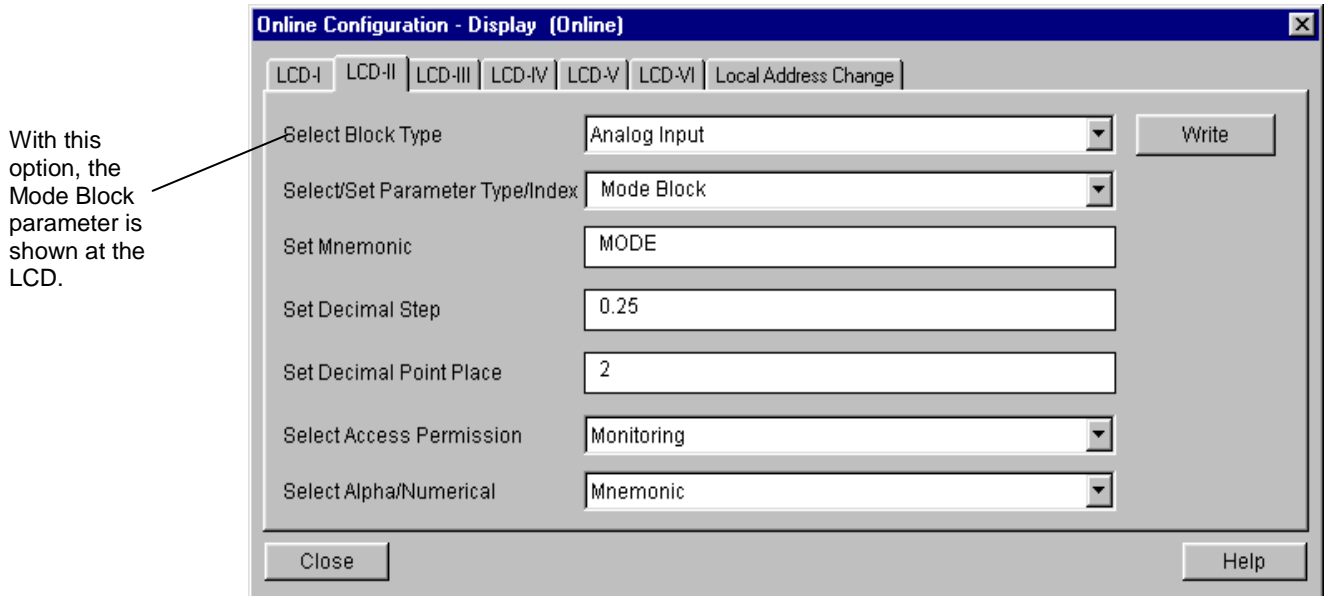

Figure 3.30 – Parameters for Local Adjustment Configuration

Programming Using Local Adjustment

The local adjustment is completely configured by Profibus View or Simatic PDM or any other configuration tool. It means, the user can select the best options to fit his application. From factory, it is configured with the options to set the Upper and Lower trim, for monitoring the input transducer output and check the Tag. Normally, the transmitter is much better configured by **configuration tool**, but the local functionality of the LCD permits an easy and fast action on certain parameters, since it does not rely on communication and network wiring connections. Among the possibilities by Local Adjustment, the following options can be emphasized: Mode block, Outputs monitoring, Tag visualization and Tuning Parameters setting.

The interface between the user is also described very detailed on the "General Installation, Operation and Maintenance Procedures Manual" Please take a detailed look at this manual in the chapter related to "Programming Using Local Adjustment". It is significantly the resources on this transducer display, also all the Series 303 field devices from **SMAR** has the same methodology to handle with it. So, since the user has learned once, he is capable to handle all kind of field devices from **SMAR**. This Local adjustment configuration is a suggestion only. The user may choose his preferred configuration via configuration toll, simply configuring the display block.

The jumper W1 on top of the main circuit board must be in place and the positioner must be fitted with digital display for access to the local adjustment. Without display, the local adjustment is not possible.



Figure 3.31 - Local Adjustment Holes

Table 3.5 shows the actions on the **Z** and **S** holes on the **LD293** when Local Adjustment is enabled.

HOLE	ACTION
Z	Initializes and rotates through the available functions.
S	Selects the function shown in the display.

Table 3.5 - Purpose of the holes on the Housing

J1 Jumper Connections

If J1 (see figure 3.32) is connected to ON, then simulation mode in the AO block is enabled.

W1 Jumper Connections

If W1 is connected to ON, the local adjustment programming tree is enabled and then important block parameters can be adjusted and communication can be pre-configured via local adjustment.

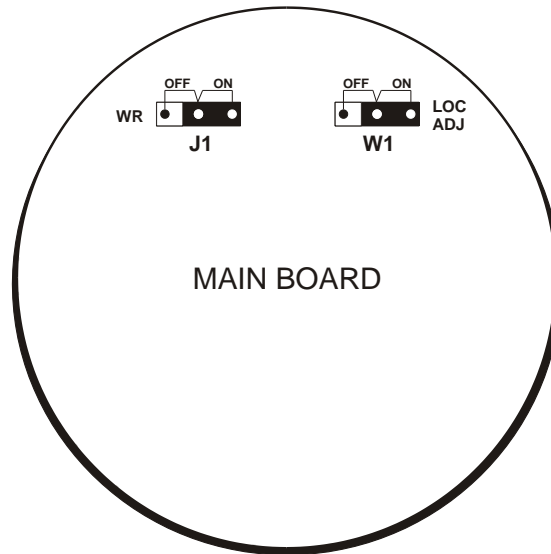
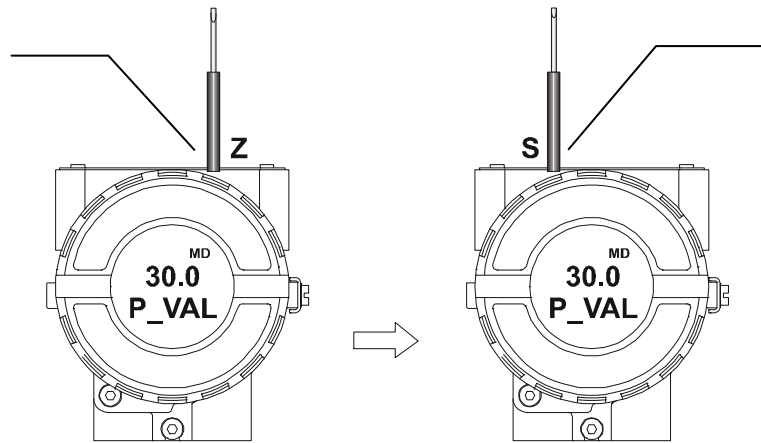

Figure 3.32 - J1 and W1 Jumpers

In order to start the local adjustment, place the magnetic tool in **Z** orifice and wait until letters **MD** are displayed.



Place the magnetic tool in **S** orifice and wait for 5 seconds.

Figure 3.33 - Step 1 - LD293

Remove the magnetic tool from **S** orifice.

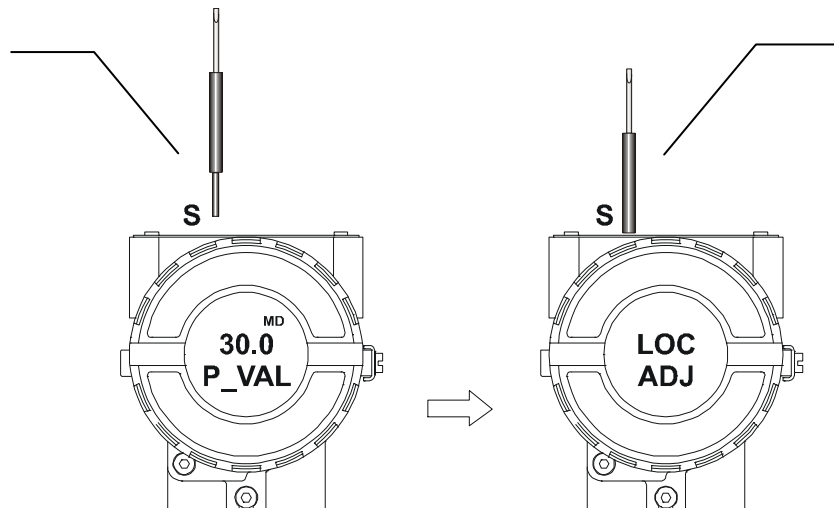

Insert the magnetic tool in **S** orifice once more and **LOC ADJ** should be displayed.

Figure 3.4 - Step - LD293

Place the magnetic tool in **Z** orifice. If this is the first configuration, the option shown on the display is the **TAG** with its corresponding mnemonic configured by the configurator. Otherwise, the option shown on the display will be the one configured in the prior operation. By keeping the tool inserted in this orifice, the local adjustment menu will rotate.

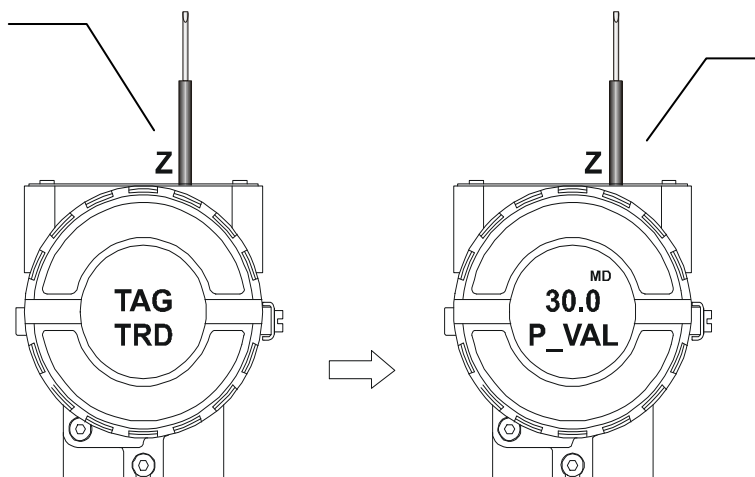

Suppose to be the first configuration. In this case, the option (**P_VAL**) is showed with its respective value. To change this value, insert the magnetic tool in **S** orifice, and keep it there until getting the desired value.

Figure 3.35 – Step 3 – LD293

In order to select the next function, the lower value (**LOWER**), move the magnetic tool from **S** to **Z** orifice. An arrow pointing upward (↑) increments the value and an arrow pointing downward (↓) decrements the value. In order to increment the value, insert and keep the tool in **S** orifice until getting the desired value.

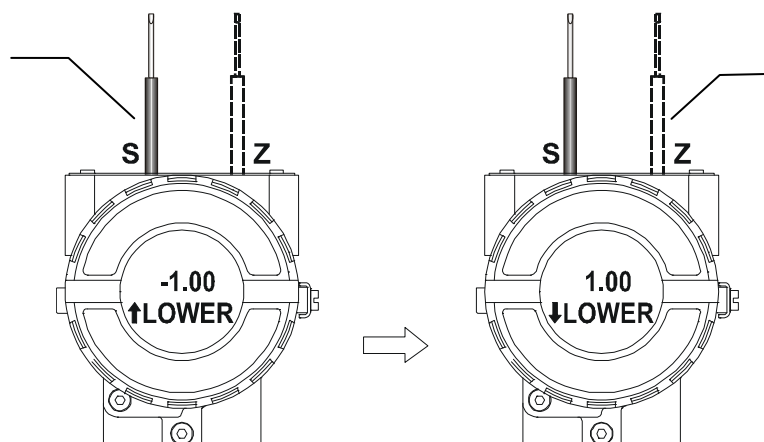

In order to decrement the lower value, place the magnetic tool in **Z** orifice to shift the arrow to the downward position. After that, insert and keep the tool in **S** until getting the desired value.

Figure 3.36 - Step 4 - LD293

In order to select the next function, the upper value (**UPPER**), move the magnetic tool from **S** to **Z** orifice. An arrow pointing upward (↑) increments the value and an arrow pointing downward (↓) decrements the value. In order to increment the value, insert and keep the tool in **S** orifice until getting the desired value.

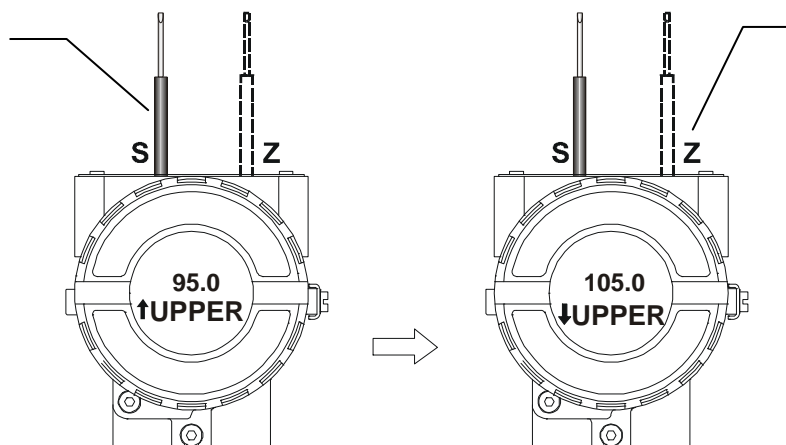

In order to decrement the upper value, place the magnetic tool in **Z** orifice to shift the arrow to the downward position. After that, insert and keep the tool in **S** orifice until getting the desired value.

Figure 3.37 - Step 5 - LD293

In order to select the next function, the address value (**ADDR**), move the magnetic tool from **S** to **Z** orifice. An arrow pointing upward (↑) increments the value and an arrow pointing downward (↓) decrements the value. In order to increment the value, insert and keep the tool in **S** orifice until getting the desired value.

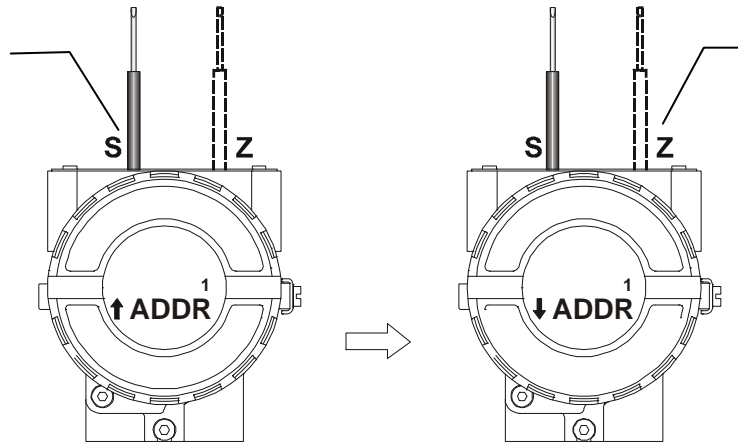

In order to decrement the address value, place the magnetic tool in **Z** orifice to shift the arrow to the downward position. After that, insert and keep the tool in **S** orifice until getting the desired value.

Figure 3.38 - Step 6 – LD293

Cyclical Diagnosis

Via cyclic communication is possible to verify diagnostics from the **LD293** using the Profibus Master Class 1 or even via acyclic communication via Master Class 2. The Profibus-PA devices provide up to 4 standard diagnoses bytes via Physical Block (see figure 3.39 and 3.40) and when the most significant bit of the fourth Byte is "1", the diagnose will extend the information in more 6 bytes. These Diagnosis bytes can also be monitored via cyclic tools.

Len of status bytes	Status Type	Physical Block Slot	Status		From Physical Block	
			Appears	Disappears	Standard Diagnostic	Extended Diagnostic
08 - Standard Diag 0E - Ext Diag	FE	01	01 - Appears	02- Disappears	4 bytes	6 bytes vendor specific

When bit 55 (byte 4, MSB)is "1":
the device has extended diagnostic

Figure 3.39 – Cyclical Diagnosis

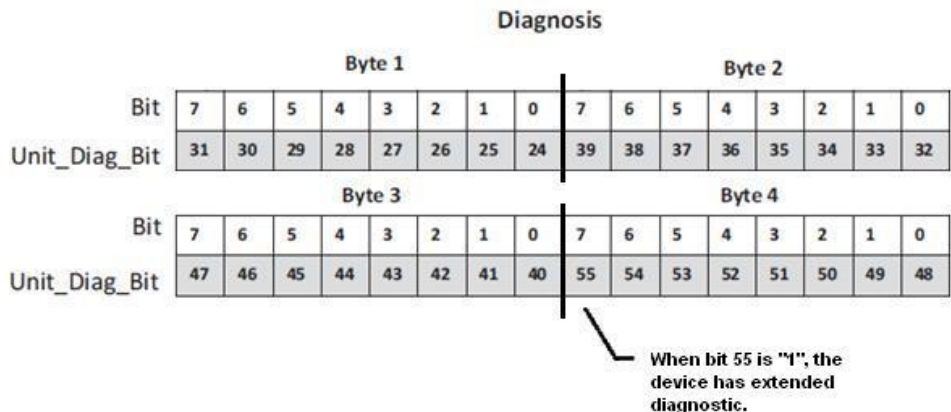

Figure 3.40 – Cyclic Diagnosis mapping for 4 bytes of Physical Block.

Unit_Diag_bit is described in the GSD file Profibus-PA device.

See below a description part of a GSD file for the 4 bytes and more detail:

```

;----- Description of device related diagnosis: -----
;

```

```

Unit_Diag_Bit(16) = "Error appears"
Unit_Diag_Bit(17) = "Error disappears"
;
;Byte 01
Unit_Diag_Bit(24) = "Hardware failure electronics"
Unit_Diag_Bit(25) = "Hardware failure mechanics"
Unit_Diag_Bit(26) = "Not used 26"
Unit_Diag_Bit(27) = "Electronic temperature alarm"
Unit_Diag_Bit(28) = "Memory error"
Unit_Diag_Bit(29) = "Measurement failure"
Unit_Diag_Bit(30) = "Device not initialized"
Unit_Diag_Bit(31) = "Device initialization failed"

;Byte 02
Unit_Diag_Bit(32) = "Not used 32"
Unit_Diag_Bit(33) = "Not used 33"
Unit_Diag_Bit(34) = "Configuration invalid"
Unit_Diag_Bit(35) = "Restart"
Unit_Diag_Bit(36) = "Coldstart"
Unit_Diag_Bit(37) = "Maintenance required"
Unit_Diag_Bit(38) = "Characteristics invalid"
Unit_Diag_Bit(39) = "Ident_Number violation"

;Byte 03
Unit_Diag_Bit(40) = "Not used 40"
Unit_Diag_Bit(41) = "Not used 41"
Unit_Diag_Bit(42) = "Not used 42"
Unit_Diag_Bit(43) = "Not used 43"
Unit_Diag_Bit(44) = "Not used 44"
Unit_Diag_Bit(45) = "Not used 45"
Unit_Diag_Bit(46) = "Not used 46"
Unit_Diag_Bit(47) = "Not used 47"

;byte 04
Unit_Diag_Bit(48) = "Not used 48"
Unit_Diag_Bit(49) = "Not used 49"
Unit_Diag_Bit(50) = "Not used 50"
Unit_Diag_Bit(51) = "Not used 51"
Unit_Diag_Bit(52) = "Not used 52"
Unit_Diag_Bit(53) = "Not used 53"
Unit_Diag_Bit(54) = "Not used 54"
Unit_Diag_Bit(55) = "Extension Available"

;Byte 05 TRD Block & PHY Block
Unit_Diag_Bit(56) = "Sensor failure"
Unit_Diag_Bit(57) = "Temperature Out of work range"
Unit_Diag_Bit(58) = "Pressure Sensor Out of High limit"
Unit_Diag_Bit(59) = "Pressure Sensor Out of Low limit"
Unit_Diag_Bit(60) = "Calibration Error - Check XD_ERROR parameter"
Unit_Diag_Bit(61) = "Primary Value Unit not valid"
Unit_Diag_Bit(62) = "No valid polynomial version"
Unit_Diag_Bit(63) = "Device is writing lock"

;byte 06 AI Block
Unit_Diag_Bit(64) = "Simulation Active in AI Block"
Unit_Diag_Bit(65) = "Fail Safe Active in AI Block"
Unit_Diag_Bit(66) = "AI Block in Out of Service"
Unit_Diag_Bit(67) = "AI Block Output out of High limit"
Unit_Diag_Bit(68) = "AI Block Output out of Low limit"
Unit_Diag_Bit(69) = "No assigned channel to AI Block"
Unit_Diag_Bit(70) = "Not used 70"
Unit_Diag_Bit(71) = "Not used 71"

```

;byte 07 TOT Block
Unit_Diag_Bit(72) = "Not used 72"
Unit_Diag_Bit(73) = "Not used 73"
Unit_Diag_Bit(74) = "Not used 74"
Unit_Diag_Bit(75) = "Not used 75"
Unit_Diag_Bit(76) = "Not used 76"
Unit_Diag_Bit(77) = "Not used 77"
Unit_Diag_Bit(78) = "Not used 78"
Unit_Diag_Bit(79) = "Not used 79"

;byte 08
Unit_Diag_Bit(80) = "Not used 80"
Unit_Diag_Bit(81) = "Not used 81"
Unit_Diag_Bit(82) = "Not used 82"
Unit_Diag_Bit(83) = "Not used 83"
Unit_Diag_Bit(84) = "Not used 84"
Unit_Diag_Bit(85) = "Not used 85"
Unit_Diag_Bit(86) = "Not used 86"
Unit_Diag_Bit(87) = "Not used 87"

;byte 09
Unit_Diag_Bit(88) = "Not used 88"
Unit_Diag_Bit(89) = "Not used 89"
Unit_Diag_Bit(90) = "Not used 90"
Unit_Diag_Bit(91) = "Not used 91"
Unit_Diag_Bit(92) = "Not used 92"
Unit_Diag_Bit(93) = "Not used 93"
Unit_Diag_Bit(94) = "Not used 94"
Unit_Diag_Bit(95) = "Not used 95"

;byte 10
Unit_Diag_Bit(96) = "Not used 96"
Unit_Diag_Bit(97) = "Not used 97"
Unit_Diag_Bit(98) = "Not used 98"
Unit_Diag_Bit(99) = "Not used 99"
Unit_Diag_Bit(100) = "Not used 100"
Unit_Diag_Bit(101) = "Not used 101"
Unit_Diag_Bit(102) = "Not used 102"
Unit_Diag_Bit(103) = "Not used 103"

NOTE

If the FIX flag is active on LCD, the **LD293** is configured to "Profile Specific" mode. When in "Manufacturer Specific" mode, the Identifier Number is 0x0906. Once the Identifier_Number_Selector is changed from "Profile Specific" to "Manufacturer Specific" or vice-versa, one must wait 5 seconds while is saved. Then, turn the **LD293** off and turn it on again. So, the Identifier Number is updated to the communication level. If the equipment is in "Profile Specific" and using the GSD file Identifier Number equals 0x0906, the acyclic communication will work with the tools based on EDDL, FDT/DTM, but no cyclic communication with the Profibus-DP master.

Section 4

MAINTENANCE PROCEDURES

General

NOTE
Equipments installed in hazardous atmospheres must be inspected in compliance with the IEC60079-17 standard.

SMAR Series 303 devices are extensively tested and inspected before delivery to the end user. Nevertheless, during their design and development, consideration was given to the possibility of repairs being made by the end user, if necessary.

In general, it is recommended that end users do not try to repair printed circuit boards. Spare circuit boards may be ordered from **SMAR** whenever necessary. Refer to the item "Returning Materials" at the end of this Section.

The table 4.1 shows the messages of errors and potential cause.

SYMPTOM	PROBABLE SOURCE OF PROBLEM
NO COMMUNICATION	<ul style="list-style-type: none"> ▪ Transmitter Connections Check wiring polarity and continuity. Check for shorts or ground loops. Check if the power supply connector is connected to main board. Check if the shield is not used as a conductor. It should be grounded at one end only.
	<ul style="list-style-type: none"> ▪ Power Supply Check power supply output. The voltage must be between 9 - 32 VDC at the LD293 terminals. Noise and ripple should be within the following limits: <ul style="list-style-type: none"> a) 16 mV peak to peak from 7.8 to 39 KHz. b) 2 V peak to peak from 47 to 63 Hz for non-intrinsic safety applications and 0.2 V for intrinsic safety applications. c) 1.6 V peak to peak from 3.9 MHz to 125 MHz.
	<ul style="list-style-type: none"> ▪ Network Connection Check that the topology is correct and all devices are connected in parallel. Check that two Terminators are OK and correctly positioned. Check that the coupler connections are OK and correctly positioned. Check that the Terminators are according to the specifications. Check length of trunk and spurs. Check spacing between couplers.
	<ul style="list-style-type: none"> ▪ Network Configuration Make sure that device address is configured correctly.
	<ul style="list-style-type: none"> ▪ Electronic Circuit Failure Check the main board for defect by replacing it with a spare one.
INCORRECT READING	<ul style="list-style-type: none"> ▪ Transmitter Connections Check for intermittent short circuits, open circuits and grounding problems. Check if the sensor is correctly connected to the LD293 terminal block.
	<ul style="list-style-type: none"> ▪ Noise, Oscillation Adjust damping Check grounding of the transmitters housing. Check that the shielding of the wires between transmitter and the panel is grounded only in one end.
	<ul style="list-style-type: none"> ▪ Sensor Check the sensor operation; it shall be within its characteristics. Check sensor type; it shall be the type and standard that the LD293 has been configured to. Check if process is within the range of the sensor and the LD293.

Table 4.1 - Messages of Errors and Potential Cause

If the problem is not presented in the table above follow the Note below:

NOTE
<p>The Factory Init should be tried as a last option to recover the equipment control when the equipment presents some problem related to the function blocks or the communication. This operation must only be carried out by authorized technical personnel and with the process offline, since the equipment will be configured with standard and factory data.</p> <p>This procedure resets all the configurations run on the equipment, after which a partial download should be performed. With exception to the equipment physical address and the gsd identifier number selector parameter. After doing this, all configurations must be remade according to their applications.</p> <p>Two magnetic tools should be used to this effect. On the equipment, withdraw the nut that fixes the identification tag on the top of the housing, so that access is gained to the "S" and "Z" holes.</p> <p>The operations to follow are:</p> <ol style="list-style-type: none">1) Switch off the equipment, insert the magnetic tools and keep them in the holes (the magnetic end in the holes);2) Feed the equipment;3) As soon as Factory Init is shown on the display, take off the tools and wait for the "5" symbol on the right upper corner of the display to unlit, thus indicating the end of the operation. <p>This procedure makes effective all the factory configuration and will eliminate eventual problems with the function blocks or with the equipment communication.</p>

Disassembly Procedure

WARNING
Do not disassemble with power on.

The Figure 4.3 an exploded view of the transmitter and will help to visualize the following.

Sensor

To remove the sensor from the electronic housing, the electrical connections (in the field terminal side) and the main board connector must be disconnected.

Loosen the hex screw (6) and carefully unscrew the electronic housing from the sensor, observing that the flat cable is not excessively twisted.

WARNING
To avoid damage do not rotate the electronic housing more than 270° starting from the fully threaded without disconnecting the electronic circuit from the sensor and from the power supply. See Figure 4.1.



Figure 4.1 – Sensor Rotation Stopper

Electronic Circuit

To remove the circuit board (5), loosen the two screws (3) that anchor the board.

WARNING

The board has CMOS components, which may be damaged by electrostatic discharges. Observe correct procedures for handling CMOS components. It is also recommended to store the circuit boards in electrostatic-proof cases.

Pull the main board out of the housing and disconnect the power supply and the sensor connectors.

Reassemble Procedure

WARNING

Do not assemble the main board with power on.

Sensor

The fitting of the sensor must be done with the main board out of the electronic housing. Mount the sensor to the housing turning clockwise until it stops. Then turn it counterclockwise until it faces the protective cover (1). Tighten the hex screw (6) to lock the housing to the sensor.

Electronic Circuit

Plug sensor connector and power supply connector to main board.

Attach the display to the main board. Observe the four possible mounting positions. (Figure 4.2 - Four Possible Positions of the Display). The **SMAR** mark indicates up position.

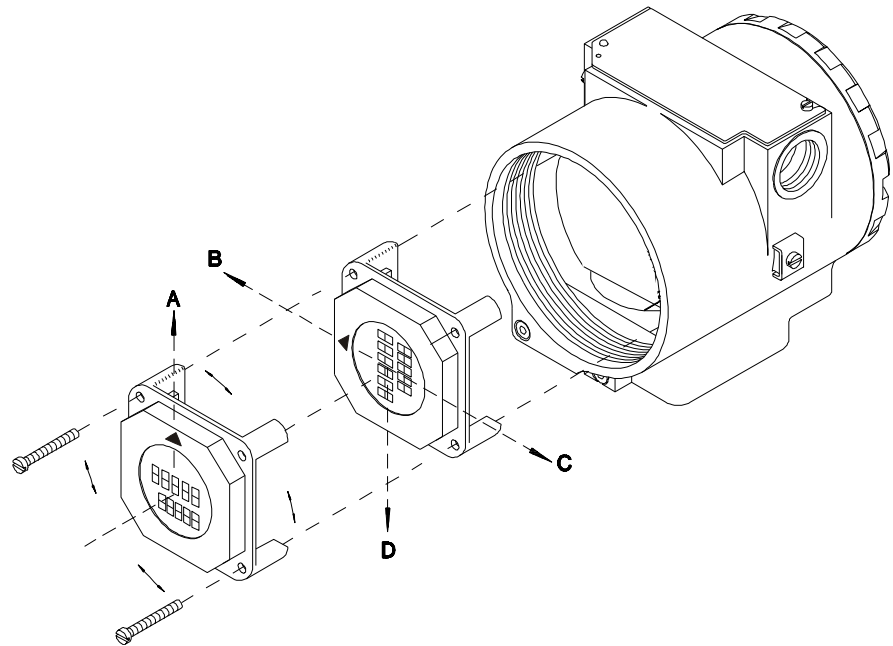

Figure 4.2 - Four Possible Positions of the Display

Anchor the main board and display with their screws (3).

After tightening the protective cover (1), mounting procedure is complete. The transmitter is ready to be energized and tested. It is recommended to open the transmitter's pressure taps to atmosphere and adjust the TRIM.

Interchangeability

In order to obtain an accurate and better temperature compensated response. Each sensor is submitted to a characterization process and the specific data is stored in an EEPROM located in the sensor body.

Every time the power is turned on, the main circuit reads the sensor serial number, should it differ from the number stored in the memory. The circuit understands that there is a new sensor and the following information is transferred from the sensor to the main circuit.

- Temperature compensation coefficients.
- Sensor's trim including 5-point characterization curve.
- Sensor characteristics: type, range, diaphragm material and fill fluid.

The other transmitter characteristics are stored in the main circuit memory and are not affected by sensor change.

Upgrading LD291 to LD293

The sensor and casing of the LD291 is exactly the same as the **LD293**. By changing the circuit board of the LD291 it becomes a **LD293**. The display on LD291 version 5.XX, is the same as on **LD293** and can therefore be used with the **LD293** upgrade circuit board. With a LD301 version three or earlier, that display can not be used.

Upgrading the LD291 to a **LD293** is therefore very much the same as the procedure for replacing the main board described above.

To remove the circuit board (5), loosen the two screws (3) that anchor the board.

Caution with the circuit boards must be taken as mentioned above.

Pull the LD291 main board out of the housing and disconnect the power supply and the sensor connectors.

Put in the **LD293** main board reversing the procedure for removing the LD291 circuit.

Returning Materials

Should it become necessary to return the transmitter and/or configurator to **SMAR**, simply contact our office, informing the defective instrument serial number, and return it to our factory.

If it becomes necessary to return the transmitter and/or configurator to Smar, simply contact our office, informing the defective instrument's serial number, and return it to our factory. In order to speed up analysis and solution of the problem, the defective item should be returned with the Service Request Form (SRF – Appendix B) properly filled with a description of the failure observed and with as much details as possible. Other information concerning to the instrument operation, such as service and process conditions, is also helpful.

Instruments returned or to be revised outside the guarantee term should be accompanied by a purchase order or a quote request.

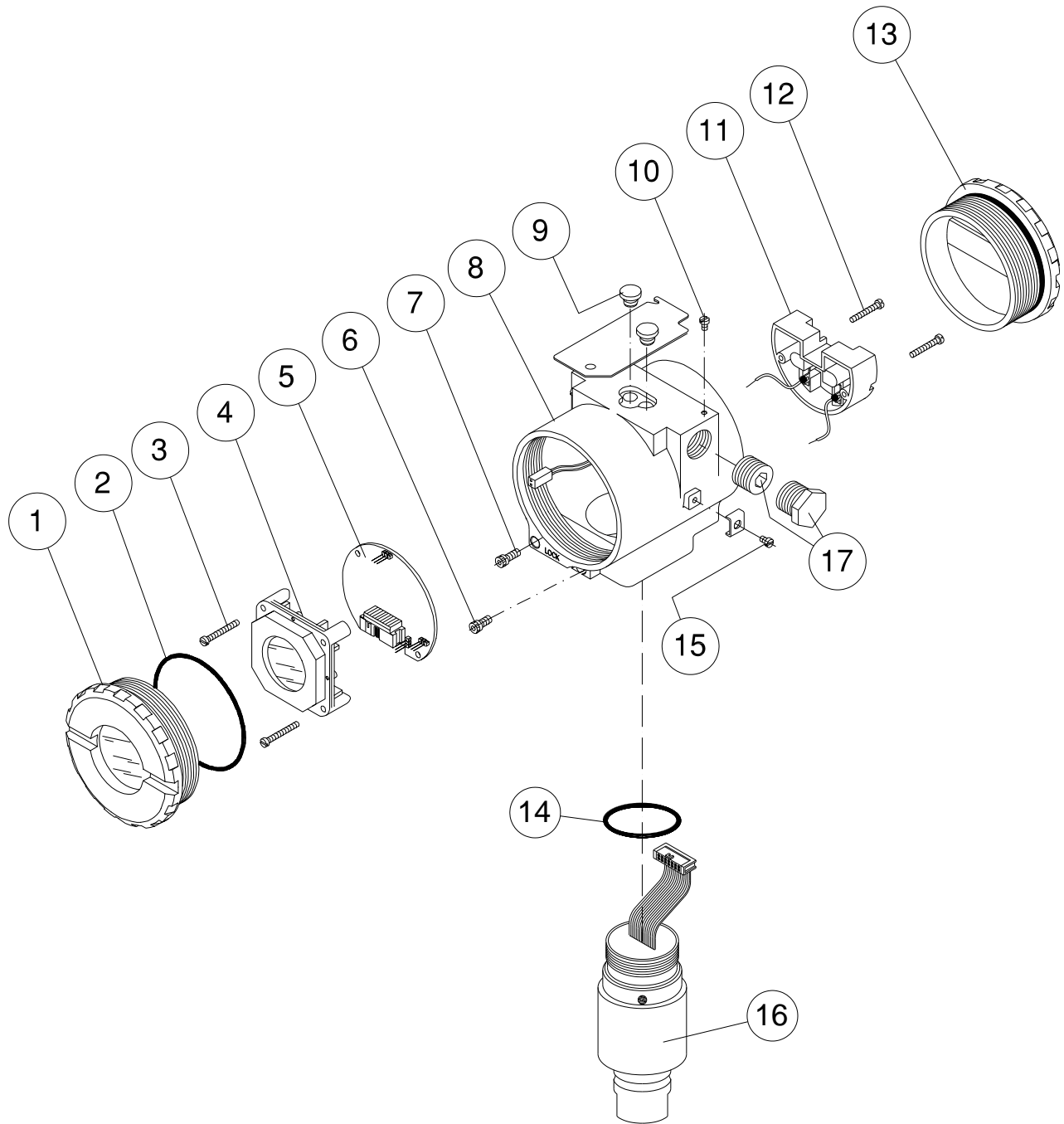

Figure 4.3 – Exploded View

ACCESSORIES	
ORDERING CODE	DESCRIPTION
SD1	Magnetic Tool for Local Adjustment
BC1	Fieldbus/RS232 Interface
PS302	Power Supply
FDI302	Field Device Interface
BT302	Terminator
DF47	Intrinsic Safety Barrier
DF48	Fieldbus Repeater

SPARE PARTS LIST			
DESCRIPTION OF PARTS	POSITION	CODE	CATEGORY (NOTE 1)
HOUSING (NOTE 2)	8	(NOTE 6)	
COVER (INCLUDES O'RING)			
Aluminum	1 and 13	204-0102	
316 SS	1 and 13	204-0105	
COVER WITH WINDOW FOR INDICATION (INCLUDES O'RING)			
Aluminum	1	204-0103	
316 SS	1	204-0106	
COVER LOCKING SCREW	7	204-0120	
SENSOR LOCKING SCREW			
Without Head M6 Screw	6	400-1121	
EXTERNAL GROUND SCREW	15	204-0124	
IDENTIFICATION PLATE FIXING SCREW	10	204-0116	
DIGITAL INDICATOR	4	214-0108	
TERMINAL INSULATOR	11	400-0059	
MAIN ELECTRONIC CIRCUIT BOARD - GLL 892 - LD293	5	400-0336	A
CONDUIT PLUG			
1/2 NPT Internal in Bichromatized Carbon Steel	17	400-0808	
1/2 NPT Internal in 304 SST	17	400-0809	
M20 X 1.5 External in 316 SST	17	400-0810	
PG 13.5 External in 316 SST	17	400-0811	
O'RINGS (NOTE 3)			
Cover, Buna-N	2	204-0122	B
Neck, Buna-N	14	204-0113	B
TERMINAL HOLDING SCREW.			
Housing in 316 Stainless Steel	12	204-0119	
MOUNTING BRACKET FOR 2" PIPE MOUNTING (NOTE 5)			
Carbon Steel	-	209-0801	
Stainless Steel 316	-	209-0802	
Carbon Steel with bolts, nuts, washers and U-clamp in 316SS	-	209-0803	
LOCAL ADJUSTMENT PROTECTION CAP	9	204-0114	
SENSOR	16	(NOTE 4)	B

Table 4.2 - Spare Part List

NOTE	
1.	For category A, it is recommended to keep, in stock, 25 parts installed for each set, and for category B, 50.
2.	Includes Terminal Block, Bolts, caps and Identification plate without certification.
3.	0-Rings and Backup Rings are packaged in packs of 12 units.
4.	To specify sensors, use the ordering code for sensor.
5.	Including U-clamp, nuts, bolts and washers.
6.	To specify housing, use the ordering code for housing.

Ordering Code for Housing

CODE	DESCRIPTION	
400-1314 - 2	HOUSING: LD293	
	Option	Communication Protocol
	P	PROFIBUS PA
	Option	Electrical Connection
	0	½ NPT
	A	M20 X 1.5
	B	PG13.5
	Option	Material
	H0	Aluminium (IP/Type)
	H1	316 SST (IP/Type)
	H2	Aluminium – for saline atmospheres (IPW/Type X)
	H4	Aluminium Copper Free (IPW/Type X)
	Option	Painting
	P0	Gray Munsell N 6,5
	P8	Without Painting
	P9	Safe Blue Base EPÓXI – electrostatic painting

400-1314 - 2	P	0	H0	P0
--------------	---	---	----	----

Ordering Code for Sensor

209-0241	SENSOR FOR PRESSURE GAGE TRANSMITTER							
CODE	Type	Range Limits			Range Limits			
		Min.	Max.	Unit	Min.	Max.	Unit	
M2	Gage	12.5	500	mbar	5.02	201.09	inH2O	
M3	Gage	62.5	2500	mbar	25.13	1005.45	inH2O	
M4	Gage	0.625	25	bar	157.1	10054.5	inH2O	
M5	Gage	6.25	250	bar	90.65	3625.94	psi	
CODE	Diaphragm Material and Fill Fluid							
1	316L SST - Silicone Oil							
2	316L SST – Inert Fluorolube Oil (2)							
3	Hastelloy C276 - Silicone Oil (1)							
4	Hastelloy C276 – Inert Fluorolube Oil (2)							
D	316L SST – Inert Krytox Oil (2)							
E	Hastelloy C276 – Inert Krytox Oil (2)							
Q	316L SST – Inert Halocarbon 4.2 Oil (2)							
R	Hastelloy C276 – Inert Halocarbon 4.2 Oil (2)							
CODE	Process Connections Material							
H	Hastelloy C276 (1)							
I	316L SST							
Z	User's specifications							
CODE	Process Connections							
1	1/2 - 14 NPT - Female			U				1/2 BSP – Male
A	M20 X 1,5 Male			V				Valve Manifold integrated to the transmitter
G	G 1/2 A DIN 16288 - Form B (3)			X				1" NPT Sealed
H	G 1/2 DIN 16288 - Form D (3)			Z				User's specifications
M	1/2 - 14 NPT - Male							

209-0241	M2	1	I	A
----------	----	---	---	---

← Typical Model Number

NOTE

- (1) Meets NECE MR - 01 - 75/ISO 15156 recommendations.
- (2) Inert Fluid: safe for oxygen service.
- (3) The DIN 16288 standards was substituted by the DIN EN 837-1.

209-0241 SPARE PART NUMBER FOR SANITARY PRESSURE SENSOR							
CODE	Type	Range Limits			Range Limits		
		Min.	Max.	Unit	Min.	Max.	Unit
2	Sanitary	12.5	500	mbar	5.02	201.09	inH ₂ O
3	Sanitary	62.5	2500	mbar	25.13	1005,45	inH ₂ O
4	Sanitary	0.625	25	bar	157.1	10054.5	inH ₂ O
5	Sanitary	6.25	55.15	bar	90.65	799.89	psi
CODE	Diaphragm Material						
H	Hastelloy C276			M	Monel		
I	316L SST			T	Tantalum		
CODE	Fill Fluid (Low Side)						
D	Silicone DC-704 Oil (2)				N	Propileno Glicol Neobee M20 Oil (Approved 3A) (3)	
F	Inert Fluorolube MO-10 Oil (1) (4)				S	Silicone DC-200/20 Oil (2)	
K	Inert Krytox Oil (1) (4)				T	Syltherm 800 Oil	
CODE	Process Connections						
B	Thread IDF - 2" 300#			H	DN40 300# - DIN 11851		
C	Thread RJT - 2" 300#			P	Tri-Clamp - 2" 800#		
D	Tri-Clamp - 2" 300#			Q	Tri-Clamp - 1 1/2" 800#		
E	Thread SMS - 2" 300#			Z	User's specifications		
F	Tri-Clamp - 1 1/2" 300#						
CODE	Optional Items						

209-0241 | 2 | I | N | D | * ← Typical Model Number

*Leave blank for no optional items.

NOTES

- (1) Meets NACE MR - 01 - 75/ISO 15156 recommendations.
- (2) Silicone Oil is not recommended for Oxygen (O₂) or Chlorine service.
- (3) Compliant with 3A-7403 standard for food and other applications where sanitary connections are required:
 - Neobee M20 Fill Fluid
 - Finishing wet Face: 0,8 µm Ra (32 µ" AA)
 - Wet O-Ring: Viton, Buna-N and Teflon
- (4) Inert Fluid: Oxygen Compatibility, safe for oxygen service.

209-0241 SENSOR FOR FLANGED PRESSURE TRANSMITTER											
COD.	Type	Range Limits		Min. Span	Unit	Range Limits		Min. Span	Unit		
		Min.	Max.			Min.	Max.				
L2	Level	-50	50	1,25	kPa	-200	200	5	inH ₂ O	Note: The range can be extended up to 0.75 LRL and 1.2 URL with small degradation of accuracy. The upper range value must be limited to the flange rating.	
L3	Level	-250	250	2,08	kPa	-36	36	0,3	psi		
L4	Level	-2500	2500	20,83	kPa	-360	360	3	psi		
L5	Level	-25000	25000	208,30	kPa	-3625	3625	30,2	psi		
COD. Diaphragm Material (Sensor) and Fill Fluid (Sensor)											
1	316L SST - Silicone Oil										
COD. Process Connection											
U	1" 150# (ANSI B16.5)				C	3" 600# (ANSI B16.5)					
V	1" 300# (ANSI B16.5)				3	4" 150# (ANSI B16.5)					
W	1" 600# (ANSI B16.5)				4	4" 300# (ANSI B16.5)					
O	1½" 150# (ANSI B16.5)				D	4" 600# (ANSI B16.5)					
P	1½" 300# (ANSI B16.5)				5	DN25 PN 10/40					
Q	1½" 600# (ANSI B16.5)				R	DN40 PN 10/10					
9	2" 150# (ANSI B16.5)				E	DN50 PN10/40					
A	2" 300# (ANSI B16.5)				6	DN80 PN25/40					
B	2" 600# (ANSI B16.5)				7	DN100 PN10/16					
1	3" 150 # (ANSI B16.5)				8	DN100 PN25/40					
2	3" 300# (ANSI B16.5)				Z	User's specifications					
COD. Type and Material Flange											
2	316L SST (integral flange)				6	Carbon Steel (slip-on flange)					
4	304 SST (slip-on flange)				Z	User's specifications					
5	316 SST (slip-on flange)										
COD. Extension Length											
0	0 mm (0")				3	150 mm (6")					
1	50 mm (2")				4	200 mm (8")					
2	100 mm (4")				Z	User's specifications					
COD. Diaphragm Material / Extension (Process Connection)											
1	316 L SST / 316 SST				5	Titanium / 316 SST (3)					
2	Hastelloy C276 / 316 SST				6	316L SST with Teflon Lining					
3	Monel 400 / 316 SST				L	316L SST with Halar Lining					
4	Tantalum / 316 SST (3)				Z	User's specifications					
COD. Fill Fluid (Process Connection)											
S	Silicone DC-200/20 Oil				H	Halocarbon 4.2 Oil					
F	Inert Fluorolube MO-10 Oil (4)				N	Propileno Glicol (Neobee) Oil					
D	Silicone DC-704 Oil				T	Syltherm 800 Oil					
K	Krytox Oil				Z	User's specifications					
COD. Lower Housing Material											
0	Without Lower Housing				4	Duplex (UNS 31803)					
1	316L SST				5	304L SST					
2	Hastelloy C276				Z	User's specifications					
3	Super Duplex (UNS 32750)										
COD. Gasket Material											
0	Without Gasket				I	316L SST					
C	Copper				T	Teflon (PTFE)					
G	Grafoil (Flexible Lead)				Z	User's specifications					
209-0241	L2	1	1	2	0	1	S	1	0	TYPICAL MODEL NUMBER	

NOTES

(1) Silicone Oils not recommendations for Oxygen (O₂) or Chlorine service.

(2) Not applicable for vacuum service.

(3) Attention, check corrosion rate for the process, tantalum plate 0.1 mm, AISI 316L extension 3 to 6mm.

(4) Fluorolube fill fluid is not available for Monel diaphragm.

(5) Inert Fluid: Safe for oxygen service.

Section 5

TECHNICAL CHARACTERISTICS

Functional Specifications									
Process Fluid	Liquid, gas or vapor.								
Output Signal	Profibus PA, Digital only, Complies with IEC 61158-2(H1): 31.25 kbit/s and voltage mode with bus power.								
Power Supply	Bus powered 9 - 32 VDC. Current consumption quiescent 12 mA. Output impedance: non-intrinsic safety from 7.8 kHz - 39 kHz should be greater or equal to 3 k Ohm. Intrinsic safety output impedance (assuming an IS barrier in the power supply) from 7.8 kHz - 39 kHz should be greater or equal to 400 Ohm.								
Indicator	Optional 4½-digit numerical and 5-character alphanumeric LCD indicator.								
Hazardous Area Certifications	Explosion proof (FM, NEMKO, CEPEL), dust ignition proof and non-incendive (FM) and intrinsic safety (FM, CSA, NEMKO, EXAM, CEPEL, NEPSI).								
European Directive Information	<p>Authorized representative in European Community Smar GmbH-Rheingaustrasse 9-55545 Bad Kreuznach</p> <p>PED Directive (97/23/EC) – Pressure Equipment Directive This product is in compliance with the directive and it was designed and manufactured in accordance with sound engineering practice using several standards from ANSI, ASTM, DIN and JIS.</p> <p>EMC Directive (2004/108/EC) - Elettromagnetic Compatibility The EMC test was performed according to IEC standard: IEC61326-1:2006, IEC61326-2-3:2006, IEC61000-6-4:2006, IEC61000-6-2:2005. For use in environment only. Keep the shield insulated at the instrument side, connecting the other one to the ground if necessary to use shielded cable.</p> <p>ATEX Directive (94/9/EC) – Equipment and protective systems intended for use in potentially explosive atmospheres. This product was certified according European Standards at NEMKO and EXAM (old DMT). The certified body for manufacturing quality assessment is EXAM (number 0158).</p> <p>LVD Directive 2006/95/EC – Electrical Equipment designed for use within certain voltage limits According the LVD directive Annex II the equipment under ATEX “Electrical equipment for use in an explosive atmosphere” directive are excluded from scope from this directive.</p> <p>The EC declarations of conformity for all applicable European directives for this product can be found at www.smar.com.</p>								
Temperature Limits	<table border="1"> <tr> <td>Ambient:</td> <td>-40 to 85 °C (-40 to 185 °F) -15 to 85 °C (-59 to 185 °F) (LD290I)</td> </tr> <tr> <td>Process:</td> <td>-40 to 100 °C (-40 to 212 °F) (Silicone Oil) 0 to 85 °C (-32 to 185 °F) (Inert Fluorolube Oil) -25 to 85 °C (-13 to 185 °F) Viton O’ring -40 to 150 °C (-40 to 302 °F) (LD290L) -15 to 150 °C (-59 to 302 °F) (LD290I)</td> </tr> <tr> <td>Storage:</td> <td>40 to 100 °C (-40 to 212 °F)</td> </tr> <tr> <td>Display</td> <td>-20 to 80 °C (-4 to 176 °F) -40 to 85 °C (-40 to 185 °F) (without damage)</td> </tr> </table>	Ambient:	-40 to 85 °C (-40 to 185 °F) -15 to 85 °C (-59 to 185 °F) (LD290I)	Process:	-40 to 100 °C (-40 to 212 °F) (Silicone Oil) 0 to 85 °C (-32 to 185 °F) (Inert Fluorolube Oil) -25 to 85 °C (-13 to 185 °F) Viton O’ring -40 to 150 °C (-40 to 302 °F) (LD290L) -15 to 150 °C (-59 to 302 °F) (LD290I)	Storage:	40 to 100 °C (-40 to 212 °F)	Display	-20 to 80 °C (-4 to 176 °F) -40 to 85 °C (-40 to 185 °F) (without damage)
Ambient:	-40 to 85 °C (-40 to 185 °F) -15 to 85 °C (-59 to 185 °F) (LD290I)								
Process:	-40 to 100 °C (-40 to 212 °F) (Silicone Oil) 0 to 85 °C (-32 to 185 °F) (Inert Fluorolube Oil) -25 to 85 °C (-13 to 185 °F) Viton O’ring -40 to 150 °C (-40 to 302 °F) (LD290L) -15 to 150 °C (-59 to 302 °F) (LD290I)								
Storage:	40 to 100 °C (-40 to 212 °F)								
Display	-20 to 80 °C (-4 to 176 °F) -40 to 85 °C (-40 to 185 °F) (without damage)								
Turn-on Time	Performs within specifications of less than 10 seconds after power is applied to the transmitter.								
Configuration	Basic configuration may be done using local adjustment magnetic tool if device is fitted with display. Complete configuration is possible using remote configurator (Ex: Profibus View and Simatic PDM).								
Volumetric Displacement	Less than 0.15 cm ³ (0.01 in ³).								

Functional Specifications

Overpressure and Static Pressure Limits (MWP – Maximum Working Pressure)

14 MPa (138 bar) for ranges 2, 3, 4.
31 MPa (310 bar) for range 5.

For Level Ranges ANSI/DIN (models **LD290L**):
150#: 6 psia to 235 psi (-0,6 to 16 bar) to 199,4 °F (93 °C)
300#: 6 psia to 620 psi (-0,6 to 43 bar) to 199,4 °F (93 °C)
600#: 6 psia to 1240 psi (-0,6 to 85 bar) to 199,4 °F (93 °C)
PN10/16: -60 kPa to 1,02 MPa to 212 °F (100 °C)
PN25/40: -60 kPa to 2,55 MPa to 212 °F (100 °C)

Overpressures above will not damage the transmitter, but a new calibration may be necessary.

WARNING	
It is described here only the maximum pressures of the materials referenced in each rule, it can not be manufactured on request.	
Temperatures above 150 °C are not available in standard models.	

PRESSURES TABLE FOR SEAL AND LEVEL FLANGES DIN EN 1092-1 2008 STANDARD

Material Group	Pressure Class	Maximum Temperature Allowed						
		RT	100	150	200	250	300	350
Maximum Pressure Allowed (bar)								
10E0 AISI 304/304L	PN 16	16	13.7	12.3	11.2	10.4	9,6	9.2
	PN 25	25	21.5	19.2	17.5	16.3	15.1	14.4
	PN 40	40	34.4	30.8	28	26	24.1	23
	PN 63	63	63	57.3	53.1	50.1	46.8	45
	PN 100	100	86.1	77.1	70	65.2	60.4	57.6
	PN 160	160	137.9	123.4	112	104.3	96.7	92.1
PN 250	250	215.4	192.8	175	163	151.1	144	

Material Group	Pressure Class	Maximum Temperature Allowed						
		RT	100	150	200	250	300	350
Maximum Pressure Allowed (bar)								
14E0 AISI 316/316L	PN 16	16	16	14.5	13.4	12.7	11.8	11.4
	PN 25	25	25	22.7	21	19.8	18.5	17.8
	PN 40	40	40	36.3	33.7	31.8	29.7	28.5
	PN 63	63	63	57.3	53.1	50.1	46.8	45
	PN 100	100	100	90.9	84.2	79.5	74.2	71.4
	PN 160	160	160	145.5	134.8	127.2	118.8	114.2
PN 250	250	250	227.3	210.7	198.8	185.7	178.5	

Overpressure and Static Pressure Limits (MWP – Maximum Working Pressure) (continuation)

Material Group	Pressure Class	Maximum Temperature Allowed						
		RT	100	150	200	250	300	350
Maximum Pressure Allowed (bar)								
16E0 1.4410 Super Duplex 1.4462 Duplex	PN 16	16	16	16	16	16	-	-
	PN 25	25	25	25	25	25	-	-
	PN 40	40	40	40	40	40	-	-
	PN 63	63	63	63	63	63	-	-
	PN 100	100	100	100	100	100	-	-
	PN 160	160	160	160	160	160	-	-
PN 250	250	250	250	250	250	-	-	

PRESSURES TABLE FOR SEAL AND LEVEL FLANGES ASME B16.5 2009 STANDARD

Material Group	Pressure Class	Maximum Temperature Allowed								
		-29 to 38	50	100	150	200	250	300	325	350
Maximum Pressure Allowed (bar)										
Hastelloy C276	150	20	19.5	17.7	15.8	13.8	12.1	10.2	9.3	8.4
	300	51.7	51.7	51.5	50.3	48.3	46.3	42.9	41.4	40.3
	400	68.9	68.9	68.7	66.8	64.5	61.7	57	55	53.6
	600	103.4	103.4	103	100.3	96.7	92.7	85.7	82.6	80.4
	900	155.1	155.1	154.6	150.6	145	139	128.6	124	120.7
	1500	258.6	258.6	257.6	250.8	241.7	231.8	214.4	206.6	201.1
	2500	430.9	430.9	429.4	418.2	402.8	386.2	357.1	344.3	335.3

Functional Specifications											
Overpressure and Static Pressure Limits (MWP – Maximum Working Pressure) (continuation)	Material Group	Pressure Class	Maximum Temperature Allowed								
			-29 to 38	50	100	150	200	250	300	325	350
	S31803 Duplex S32750 Super Duplex	150	Maximum Pressure Allowed (bar)								
			20	19.5	17.7	15.8	13.8	12.1	10.2	9.3	8.4
		300	51.7	51.7	50.7	45.9	42.7	40.5	38.9	38.2	37.6
		400	68.9	68.9	67.5	61.2	56.9	53.9	51.8	50.9	50.2
		600	103.4	103.4	101.3	91.9	85.3	80.9	77.7	76.3	75.3
		900	155.1	155.1	152	137.8	128	121.4	116.6	114.5	112.9
		1500	258.6	258.6	253.3	229.6	213.3	202.3	194.3	190.8	188.2
	2500	430.9	430.9	422.2	382.7	355.4	337.2	323.8	318	313.7	
	Material Group	Pressure Class	Maximum Temperature Allowed								
			-29 to 38	50	100	150	200	250	300	325	350
	AISI316L	150	Maximum Pressure Allowed (bar)								
			15.9	15.3	13.3	12	11.2	10.5	10	9.3	8.4
		300	41.4	40	34.8	31.4	29.2	27.5	26.1	25.5	25.1
		400	55.2	53.4	46.4	41.9	38.9	36.6	34.8	34	33.4
		600	82.7	80	69.6	62.8	58.3	54.9	52.1	51	50.1
		900	124.1	120.1	104.4	94.2	87.5	82.4	78.2	76.4	75.2
		1500	206.8	200.1	173.9	157	145.8	137.3	130.3	127.4	125.4
	2500	344.7	333.5	289.9	261.6	243	228.9	217.2	212.3	208.9	
	Material Group	Pressure Class	Maximum Temperature Allowed								
			-29 to 38	50	100	150	200	250	300	325	350
	AISI316	150	Maximum Pressure Allowed (bar)								
			19	18.4	16.2	14.8	13.7	12.1	10.2	9.3	8.4
300		49.6	48.1	42.2	38.5	35.7	33.4	31.6	30.9	30.3	
400		66.2	64.2	56.3	51.3	47.6	44.5	42.2	41.2	40.4	
600		99.3	96.2	84.4	77	71.3	66.8	63.2	61.8	60.7	
900		148.9	144.3	126.6	115.5	107	100.1	94.9	92.7	91	
1500		248.2	240.6	211	192.5	178.3	166.9	158.1	154.4	151.6	
2500	413.7	400.9	351.6	320.8	297.2	278.1	263.5	257.4	252.7		
Material Group	Pressure Class	Maximum Temperature Allowed									
		-29 to 38	50	100	150	200	250	300	325	350	
AISI304	150	Maximum Pressure Allowed (bar)									
		19	18.3	15.7	14.2	13.2	12.1	10.2	9.3	8.4	
	300	49.6	47.8	40.9	37	34.5	32.5	30.9	30.2	29.6	
	600	99.3	95.6	81.7	74	69	65	61.8	60.4	59.3	
	1500	248.2	239.1	204.3	185	172.4	162.4	154.6	151.1	148.1	
	2500	413.7	398.5	340.4	308.4	287.3	270.7	257.6	251.9	246.9	
Humidity Limits	0 a 100% RH										

Performance Specifications	
Reference conditions	Reference conditions: range starting at zero, temperature 25 °C (77 °F), atmospheric pressure, power supply of 24 Vdc, silicone oil fill fluid, isolating diaphragms in 316L SS and digital trim equal to lower and upper range values.
Accuracy	For ranges 2, 3, 4 and 5: ±0.075% of span (for span ≥ 0.1 URL) ±[0.0375 + 0.00375 URL/SPAN] % of span (for span < 0.1 URL)
Accuracy	For Level Transmitter: ± 0.08 % of span (for span ≥ 0.1 URL) ± [0.0504 + 0.0047 URL/span] % of span (for span < 0.1 URL)
Stability	For Insertion Transmitter: ±0.2% of span
Stability	±0.15% of URL for 5 years.
Temperature Effect	± [0.02 URL + 0.06%] of span, per 20 °C (68 °F) for span ≥ 0.2 URL ± [0.023 URL+0.045%] of span, per 20°C (68 °F) for span < 0.2 URL
	For LD290L:

Performance Specifications	
	6 mmH ₂ O per 20 °C for 4" and DN100 17 mmH ₂ O per 20 °C for 3" and DN80
Power Supply Effect	±0.005% of calibrated span per volt.
Mounting Position Effect	Zero shift of up to 250 Pa (1 inH ₂ O) which can be calibrated out. No span effect.
Electromagnetic Interference Effect	Designed to comply with, Approved according to IEC61326-1:2006, IEC61326-2-3:2006, IEC61000-6-4:2006, IEC61000-6-2:2005.

Physical Specifications	
Electrical Connection	1/2-14 NPT, PG 13.5 or M20 x 1.5. Other connections or request.
Process Connection	1/4 -18 NPT or 1/2-14 NPT (with adapter).
Wetted Parts	Isolating Diaphragms 316L SST, Hastelloy C276, Monel 400 or Tantalum.
Nonwetted Parts	<p>Electronic Housing Injected aluminum with polyester painting or 316 SST. According to NEMA Type 4X or Type 4, IP66, IP66W*. *The IP66W sealing test (immersion) was performed at 1 bar for 24 hours. For any other situation, please consult Smar. IP66W tested for 200h to according NBR 8094 / ASTM B 117 standard.</p> <p>Level Flange (LD290L) 316L SST, 304 SST and Plated Carbon Steel.</p> <p>Fill Fluid Silicone or Inert Fluorolube Oil.</p> <p>Cover O-Rings Buna-N.</p> <p>Mounting Bracket Plated Carbon Steel with polyester painting or 316 SST. Accessories (bolts, nuts, washers and U-clamp) in Carbon Steel or 316 SST.</p> <p>Identification Plate 316 SST.</p> <p>Approximate Weights < 2.0Kg (4lb): aluminum housing without mounting bracket.</p>

Ordering Code

MODEL	GAGE PRESSURE TRANSMITTERS						
LD293M	PROFIBUS PA						
CODE	Type	Range Limits			Range Limits		
		Min.	Max.	Unit	Min.	Max.	Unit
2	Gage	12.5	500	mbar	5.02	201.09	inH ₂ O
3	Gage	62.5	2500	mbar	25.13	1005.45	inH ₂ O
4	Gage	0.625	25	bar	157.1	10054.5	inH ₂ O
5	Gage	6.25	250	bar	90.65	3625.94	psi
CODE	Diaphragm Material and Fill Fluid						
1	316L SST - Silicone Oil						
2	316L SST – Inert Fluorolube Oil (2)						
3	Hastelloy C276 - Silicone Oil (1)						
4	Hastelloy C276 – Inert Fluorolube Oil (2)						
D	316L SST – Inert Krytox Oil (2)						
E	Hastelloy C276 – Inert Krytox Oil (2)						
Q	316L SST – Inert Halocarbon 4.2 Oil (2)						
R	Hastelloy C276 – Inert Halocarbon 4.2 Oil (2)						
CODE	Process Connections Material						
H	Hastelloy C276 (1)						
I	316L SST						
Z	User's specifications						
CODE	Local Indicator						
0	Without Indicator						
1	With Indicator						
CODE	Process Connections						
1	1/2 - 14 NPT - Female			U	1/2 BSP – Male		
A	M20 X 1,5 Male			V	Valve Manifold integrated to the transmitter		
G	G 1/2 A DIN 16288 - Form B			X	1" NPT Sealed		
H	G 1/2 DIN 16288 - Form D			Z	User's specifications		
M	1/2 - 14 NPT - Male						
CODE	Electrical Connections						
0	1/2 - 14 NPT (3)			A	M20 X 1.5 (5)		
1	1/2 - 14 NPT X 3/4 NPT (316 SST) - with adapter (4)			B	PG 13.5 DIN (5)		
2	1/2 - 14 NPT X 3/4 BSP (316 SST) - with adapter (6)			Z	User's specifications		
3	1/2 - 14 NPT X 1/2 BSP (316 SST) - with adapter (6)						
4	1/2 - 1/2 NPTF (316 SST) - with adapter						
5	1/2 - 3/4 NPTF (316 SST) - with adapter						
CODE	Mounting Bracket						
0	Without Mounting Bracket						
1	Carbon Steel Mounting Bracket with Carbon Steel accessories						
2	316 SST Mounting Bracket with 316 SST accessories						
7	Carbon Steel Mounting Bracket with 316 SST accessories						
A	304 SST Mounting Bracket with 316 SST accessories						
CODE	Optional Items						

LD293M 2 1 I 1 1 A 0 * TYPICAL MODEL NUMBER

* Leave blank for no optional items.

MODEL		GAGE PRESSURE TRANSMITTER (CONTINUATION)						
		COD. Housing Material (8) (9)						
H0		Aluminium (IP/TYPE)			H3		316 SST for saline atmosphere (IPW/TYPEX) (7)	
H1		316 SST (IP/TYPE)			H4		Copper Free Aluminium (IPW/TYPEX) (7)	
H2		Aluminium for saline atmosphere (IPW/TYPEX) (7)						
		COD. Identification Plate						
I1		FM: XP, IS, NI, DI		I5		CEPEL: Ex-d, Ex-ia	I7	EXAM (DMT) Grupo I, M1 Ex-ia
I3		CSA: XP, IS, NI, DI		I6		Without Certification	ID	NEPSI: Ex-ia, Ex-d
I4		EXAM (DMT): Ex-ia; NEMKO: Ex-d						
		COD. Painting						
P0		Munsell N 6,5 Gray			P5		Polyester Yellow	
P3		Polyester Black			P8		Without Painting	
P4		Epoxy White			P9		Blue Safety Base Epoxy –Eletrostatic Painting	
		COD. Tag Plate						
J0		With TAG			J2		User's specification	
J1		Without TAG						

LD293M H0 I1 P0 J0 ← TYPICAL MODEL NUMBER

Optional Items

Special Procedures	C1 –Degrease Cleaning (Oxygen or Chlorine Service)
Burnout	BD – Down Scale BU – Up Scale
Características Especiais	ZZ – User Specification

NOTES

- (1) Meets NACE material recommendation per MR-01-75.
- (2) Inert fluid: safe for oxygen service.
- (3) Certificate for use in Hazardous Locations (CEPEL, NEPSI, NEMKO, EXAM, FM, CSA).
- (4) Certificate for use in Hazardous Locations (CEPEL, CSA).
- (5) Certificate for use in Hazardous Locations (CEPEL, NEPSI, NEMKO, EXAM).
- (6) Not certified for use in hazardous locations.
- (7) IPW/TYPEX was tested for 200 hours according to NBR 8094 / ASTM B 117 standard.
- (8) IPX8 tested for 10 meters of water column for 24 hours.
- (9) Ingress Protection:

Products	CEPEL	NEMKO/EXAM	FM	CSA	NEPSI
LD29X	IP66/W	IP66/68/W	Type 4X/6/6P	Type 4X	IP67

MODEL	SANITARY PRESSURE TRANSMITTERS											
LD293S	PROFIBUS PA											
CODE	Type	Range Limits			Range Limits			Unit	Unit	Unit	Unit	
		Min.	Max.	Unit	Min.	Max.	Unit					
2	Sanitary	12.5	500	mbar	5.02	201.09	inH ₂ O					
3	Sanitary	62.5	2500	mbar	25.13	1005.45	inH ₂ O					
4	Sanitary	0.625	25	bar	157.1	10054.5	inH ₂ O					
5	Sanitary	6.25	55.15	bar	90.65	799.89	psi					
CODE	Diaphragm Material											
I	316L SST											
CODE	Fill Fluid											
S	Silicone DC-200/20 Oil											
CODE	Local Indicator											
0	Without Indicator											
1	With Indicator											
CODE	Process Connections											
B	Thread IDF - 2" 300# (2)				H	DN40 300# - DIN 11851						
C	Thread RJT - 2" 300#				P	Tri-Clamp - 2" 800# (2)						
D	Tri-Clamp - 2" 300# (2)				Q	Tri-Clamp - 1 1/2" 800# (2)						
E	Thread SMS - 2" 300# (2)				Z	User's specifications						
F	Tri-Clamp - 1 1/2" 300# (2)											
CODE	Electrical Connections											
0	1/2 - 14 NPT (3)								A	M20 X 1.5 (5)		
1	1/2 - 14 NPT X 3/4 NPT (316 SST) - with adapter (4)								B	PG 13.5 DIN (5)		
2	1/2 - 14 NPT X 3/4 BSP (316 SST) - with adapter (8)								Z	User's specifications		
3	1/2 - 14 NPT X 1/2 BSP (316 SST) - with adapter (8)											
4	1/2 - 1/2 NPTF (316 SST) - with adapter											
5	1/2 - 3/4 NPTF (316 SST) - with adapter											
CODE	O'Ring Material											
0	Without O'Ring				V	Viton (2)						
B	Buna-N (2)				Z	User's specifications						
T	Teflon (2)											
CODE	Adaptation Sleeve											
0	Without Sleeve											
1	With Adaptation Sleeve in 316 SST											
CODE	Tri-Clamp Connection											
0	Without Clamp											
2	With Tri-Clamp in 304 SST											
CODE	Diaphragm Material (Sanitary Connection)											
H	Hastelloy C276											
I	316L SST											
CODE	Fill Fluid (Sanitary Connection)											
D	Silicone DC-704 Oil											
F	Fluorolube MO-10 Oil (1)											
N	Propylene Glicol (Neobee) Oil (2)											
S	Silicone DC-200/20 Oil											
T	Syltherm 800 Oil											
Z	User's specifications											
CODE	Optional Items											

LD293S 2 I N 1 D 0 V 1 2 I D * ← Typical Model Number

*Leave blank for no optional items.

MODEL		SANITARY PRESSURE TRANSMITTERS (CONTINUATION)			
		COD.	Housing Material (6) (7)		
		H0	Aluminium (IP/TYP E)		
		H1	316 SST (IP/TYP E)		
		COD.	Identification Plate		
		I1	FM: XP, IS, NI, DI	I5	CEPEL: Ex-d, Ex-ia
		I3	CSA: XP, IS, NI, DI	I6	Without Certification
		I4	EXAM (DMT): Ex-ia; NEMKO: Ex-d		
		COD.	Painting		
		P0	Munsell N 6,5 Gray	P5	Polyester Yellow
		P3	Polyester Black	P6	Epoxy Yellow
		P4	Epoxy White		
		COD.	Tag Plate		
		J0	With TAG	J2	User's specification
		J1	Without TAG		
LD293S	H0	I1	P0	J0	← TYPICAL MODEL NUMBER

Optional Items

Special Procedures	C1 –Degrease Cleaning (Oxygen or Chlorine Service) C4 - Polishing of the sanitary connections according to 3A Certification (2)
Burnout	BD – Down Scale BU – Up Scale

NOTE

- (1) Inert Fluid: safe for oxygen service.
- (2) Compliant with 3A-7403 standard for food and other applications where sanitary connections are required:
 - Neobee M2O Fill Fluid
 - Finishing wet Face: 0.8 µm Ra (32 µ" AA)
 - Wet O-Ring: Viton, Teflon and Buna-N
- (3) Certificate for use in Hazardous Locations (CEPEL, NEPSI, NEMKO, EXAM, FM, CSA).
- (4) Certificate for use in Hazardous Locations (CEPEL, CSA).
- (5) Certificate for use in Hazardous Locations (CEPEL, NEPSI, NEMKO, EXAM).
- (6) IPX8 tested for 10 meters of water column for 24 hours.
- (7) Ingress Protection:

Produtos	CEPEL	NEMKO/EXAM	FM	CSA	NEPSI
LD29X	IP66/W	IP66/68/W	Type 4X/6/6P	Type 4X	IP67

- (8) Not certified for use in hazardous locations.

MODEL	LOW COST FLANGED PRESSURE TRANSMITTER										
LD293L	PROFIBUS PA										
COD.	Type	Range Limits		Unit	Range Limits		Unit				
		Min.	Max.		Min.	Max.					
2	Level	12.5	500	mbar	5.02	201.09	inH ₂ O				
3	Level	62.5	2500	mbar	25.13	1005.45	inH ₂ O				
4	Level	0.625	25	bar	157.1	10054.5	inH ₂ O				
5	Level	6.25	250	bar	90.65	3625.94	psi				
COD.	Diaphragm Material (Sensor) and Fill Fluid (Sensor)										
1	316L SST - Silicone Oil										
COD.	Local Indicator										
0	Without Indicator					1	With Digital Indicator				
COD.	Process Connection										
U	1" 150# (ANSI B16.5)					C	3" 600# (ANSI B16.5)				
V	1" 300# (ANSI B16.5)					3	4" 150# (ANSI B16.5)				
W	1" 600# (ANSI B16.5)					4	4" 300# (ANSI B16.5)				
O	1½" 150# (ANSI B16.5)					D	4" 600# (ANSI B16.5)				
P	1½" 300# (ANSI B16.5)					5	DN25 PN 10/40				
Q	1½" 600# (ANSI B16.5)					R	DN40 PN 10/10				
9	2" 150# (ANSI B16.5)					E	DN50 PN10/40				
A	2" 300# (ANSI B16.5)					6	DN80 PN25/40				
B	2" 600# (ANSI B16.5)					7	DN100 PN10/16				
1	3" 150 # (ANSI B16.5)					8	DN100 PN25/40				
2	3" 300# (ANSI B16.5)					Z	User's specifications				
COD.	Electrical Connection										
0	1/2 - 14 NPT (3)					5	1/2 - 3/4 NPTF (AI 316) - with adapter				
1	1/2 - 14 NPT X 3/4 NPT (AI 316) - with adapter (4)					A	M20 X 1.5 (5)				
2	1/2 - 14 NPT X 3/4 BSP (AI 316) - with adapter (12)					B	PG 13.5 DIN (5)				
3	1/2 - 14 NPT X 1/2 BSP (AI 316) - with adapter (12)					Z	User's specifications				
4	1/2 - 1/2 NPTF (AI 316) - with adapter										
COD.	Type and Material Flange										
4	304 SST (slip-on flange)					6	Carbon Steel (slip-on flange)				
5	316 SST (slip-on flange)					Z	User's specifications				
COD.	Extension Length										
0	0 mm (0")			2	100 mm (4")			4	200 mm (8")		
1	50 mm (2")			3	150 mm (6")			Z	User's specifications		
COD.	Diaphragm Material / Extension (Process Connection)										
1	316 L SST / 316 SST					5	Titanium / 316 SST (6)				
2	Hastelloy C276 / 316 SST					6	316L SST with Teflon Lining				
3	Monel 400 / 316 SST					L	316L SST with Halar Lining				
4	Tantalum / 316 SST (6)					Z	User's specifications				
COD.	Fill Fluid (Process Connection)										
S	Silicone DC-200/20 Oil					H	Halocarbon 4.2 Oil				
F	Inert Fluorolube MO-10 Oil (7)					N	Propileno Glicol (Neobee) Oil				
D	Silicone DC-704 Oil					T	Syltherm 800 Oil				
K	Krytox Oil					Z	User's specifications				
COD.	Lower Housing Material										
0	Without Lower Housing					4	Duplex (UNS 31803)				
1	316L SST					5	304L SST				
2	Hastelloy C276					Z	User's specifications				
3	Super Duplex (UNS 32750)										
COD.	Gasket Material										
0	Without Gasket					I	316L SST				
C	Copper					T	Teflon (PTFE)				
G	Grafoil (Flexible Lead)					Z	User's specifications				
COD.	Optional Items										

LD293L 2 1 1 1 0 6 2 1 S 1 T * TYPICAL MODEL NUMBER

*Leave it blank when there are not optional items.

MODEL		LOW COST FLANGED PRESSURE TRANSMITTER (CONTINUATION)			
COD.		Housing Material (10) (11)			
H0	Aluminium (IP/TYPE)		H3	316 SST for saline atmosphere (IPW/TYPEX) (9)	
H1	316 SST (IP/TYPE)		H4	Copper Free Aluminium (IPW/TYPEX) (9)	
H2	Aluminium for saline atmosphere (IPW/TYPEX) (9)				
COD.		Identification Plate			
I1	FM: XP, IS, NI, DI		I5	CEPEL: Ex-d, Ex-ia	
I3	CSA: XP, IS, NI, DI		I6	Without Certification	
I4	EXAM (DMT): Ex-ia; NEMKO: Ex-d				
I7	EXAM (DMT) Grupo I, M1 Ex-ia				
COD.		Painting			
P0	Munsell N 6,5 Gray		P6	Epoxy Yellow	
P3	Polyester Black		P8	Without Painting	
P4	Epoxy White		P9	Blue Safety Base Epoxi – Eletrostatic Painting	
P5	Polyester Yellow		PC	Safety Base Polyester – Eletrostatic Painting	
COD.		Tag Plate			
J0	With TAG		J2	User's specification	
J1	Without TAG				

LD293L H0 I1 P0 J0 ← TYPICAL MODEL NUMBER

Optional Items

Special Procedures	C1 –Degrease Cleaning (Oxygen or Chlorine Service)
Burnout	BD – Down Scale BU – Up Scale
Lower Housing Connection	U0 – With 1 Flush Connection 1/4" NPT (if supplied with lower housing) U1 – With 2 Flush Connections 1/4" NPT per 180° U2 – With 2 Flush Connections 1/4" NPT per 90° U3 – With 2 Flush Connections 1/2" - 14 NPT per 180° (with cover) U4 – Without Flush Connection

NOTES

- (1) Silicone Oils not recommendations for Oxygen (O₂) or Chlorine service.
- (2) Not applicable for vacuum service.
- (3) Certificate for use in Hazardous Locations (CEPEL, NEPSI, NEMKO, EXAM, FM, CSA).
- (4) Certificate for use in Hazardous Locations (CEPEL, CSA).
- (5) Certificate for use in Hazardous Locations (CEPEL, NEPSI, NEMKO, EXAM).
- (6) Attention, check corrosion rate for the process, tantalum plate 0.1 mm, AISI 316L extension 3 to 6mm.
- (7) Fluorolube fill fluid is not available for Monel diaphragm.
- (8) Inert Fluid: Safe for oxygen service.
- (9) IPW/TYPEX was tested for 200 hours according to NBR 8094 / ASTM B 117 standard.
- (10) IPX8 tested for 10 meters of water column for 24 hours.
- (11) Ingress Protection:

Products	CEPEL	NEMKO/EXAM	FM	CSA	NEPSI
LD29X	IP66/W	IP66/68/W	Type 4X/6/6P	Type 4X	IP67

- (12) Not certified for use in hazardous locations.

MODEL	PRESSURE TRANSMITTER WITH EXTENDED PROBE									
LD293I	PROFIBUS PA									
COD.	Type	Range Limits								
		Min.	Max.	Unit						
2	Level	12.5	500	mbar						
COD.	Diaphragm Material and Fill Fluid									
1	316L SST – Silicon Oil (1)									
COD.	Local Indicator									
0	Without Indicator									
1	With Indicator									
COD.	Fixing Transmitter									
1	Bracket in L	Z	User's specification							
2	Flanged Bracket									
3	Triclamp 3" (9)									
COD.	Electrical Connection									
0	1/2 - 14 NPT (2)	A	M20 X 1.5 (4)							
1	1/2 - 14 NPT X 3/4 NPT (316 SST) – with adapter (3)	B	PG 13.5 DIN (4)							
2	1/2 - 14 NPT X 3/4 BSP (316 SST) - with adapter (5)	Z	User's specification							
3	1/2 - 14 NPT X 1/2 BSP (316 SST) - with adapter (5)									
4	1/2 - 1/2 NPTF (316 SST) - with adapter									
5	1/2 - 3/4 NPTF (316 SST) - with adapter									
COD.	Probe Material/Diaphragm (Wetted Parts)									
A	304L SST / 316L SST									
I	316L SST / 316L SST									
U	316L SST / Hastelloy C276									
Z	User's specification									
COD.	Probe Length									
1	500 mm	6	1600 mm							
2	630 mm	7	2000 mm							
3	800 mm	8	2500 mm							
4	1000 mm	9	3200 mm							
5	1250 mm	Z	User's specification							
COD.	Probe Fill Fluid									
N	Propileno Glicol Oil (Neobee M20) (9)									
Z	User's specification									
COD.	Optional Items									
LD293I	2	1	1	3	A	I	1	N	*	← TYPICAL MODEL

*Leave blank for no optional items.

MODEL	PRESSURE TRANSMITTER WITH EXTENDED PROBE (CONTINUATION)			
	COD.	Housing Material (7) (8)		
	H0	Aluminium (IP/TYPE)	H3	316 SST for saline atmosphere (IPW/TYPEX) (6)
	H1	316 SST (IP/TYPE)	H4	Copper Free Aluminium (IPW/TYPEX) (6)
	H2	Aluminium for saline atmosphere (IPW/TYPEX) (6)		
	COD.	Identification Plate		
	IN	CEPEL: Ex-ia		
	COD.	Painting		
	P0	Munsell N 6,5 Gray	P6	Epoxy Yellow
	P3	Polyester Black	P8	Without Painting
	P4	Epoxy White	P9	Blue Safety Base Epoxi – Eletrostatic Painting
	P5	Polyester Yellow	PC	Safety Base Polyester – Eletrostatic Painting
	COD.	Tag Plate		
	J0	With TAG	J2	User's specification
	J1	Without TAG		
LD293I	H0	IN	P0	J0

← TYPICAL MODEL NUMBER

Optional Items

Special Procedures	C1 –Degrease Cleaning (Oxygen or Chlorine Service) C4 - Polishing of the sanitary connections according to 3A Certification (9)
Burnout	BD – Down Scale BU – Up Scale
Special Characteristics	ZZ – User's specifications

NOTES

- (1) Silicone Oils not recommendations for Oxygen (O₂) or Chlorine service.
- (2) Certificate for use in Hazardous Locations (CEPEL, NEPSI, NEMKO, EXAM, FM, CSA).
- (3) Certificate for use in Hazardous Locations (CEPEL, CSA).
- (4) Certificate for use in Hazardous Locations (CEPEL, NEPSI, NEMKO, EXAM).
- (5) Not certified for use in hazardous locations.
- (6) IPW/TYPEX was tested for 200 hours according to NBR 8094 / ASTM B 117 standard.
- (7) IPX8 tested for 10 meters of water column for 24 hours.
- (8) Ingress Protection:

Products	CEPEL	NEMKO/EXAM	FM	CSA	NEPSI
LD29X	IP66/W	IP66/68/W	Type 4X/6/6P	Type 4X	IP67

- (9) Compliant with 3A-7403 standard for food and other applications where sanitary connections are required:
 - Neobee M2O Fill Fluid
 - Finishing wet Face: 0.8 µm Ra (32 µ" AA)
 - Wet O-Ring: Viton, Teflon and Buna-N

CERTIFICATIONS INFORMATION

European Directive Information

Authorized representative in European Community

Smar Gmbh-Rheingaustrasse 9-55545 Bad Kreuznach

PED Directive (97/23/EC) – Pressure Equipment Directive

This product is in compliance with the directive and it was designed and manufactured in accordance with sound engineering practice using several standards from ANSI, ASTM, DIN and JIS.

EMC Directive (2004/108/EC) - Eletromagnetic Compatibility

The EMC test was performed according to IEC standard: IEC61326-1:2006, IEC61326-2-3:2006, IEC61000-6-4:2006, IEC61000-6-2:2005. For use in environment only.

Keep the shield insulated at the instrument side, connecting the other one to the ground if necessary to use shielded cable.

ATEX Directive (94/9/EC) – Equipment and protective systems intended for use in potentially explosive atmospheres.

This product was certified according European Standards at NEMKO and EXAM (old DMT). The certified body for manufacturing quality assessment is EXAM (number 0158).

LVD Directive 2006/95/EC – Electrical Equipment designed for use within certain voltage limits

According the LVD directive Annex II the equipment under ATEX “Electrical equipment for use in an explosive atmosphere” directive are excluded from scope from this directive.

The EC declarations of conformity for all applicable European directives for this product can be found at www.smar.com.

Hazardous Locations General Information

Ex Standards:

Ex Standards:

IEC 60079-0: 2008 General Requirements

IEC 60079-1:2009 Flameproof Enclosures “d”

IEC 60079-11:2009 Intrinsic Safety “i”

IEC 60079-26:2008 Equipment with equipment protection level (EPL) Ga

IEC 60529:2005 Classification of degrees of protection provided by enclosures (IP Code)

Customer responsibility:

IEC 60079-10 Classification of Hazardous Areas

IEC 60079-14 Electrical installation design, selection and erection

IEC 60079-17 Electrical Installations, Inspections and Maintenance

Warning:

Explosions could result in death or serious injury, besides financial damage. Installation of this instrument in an explosive environment must be in accordance with the national standards and according to the local environmental protection method. Before proceeding with the installation match the certificate parameters according to the environmental classification.

General Notes:

- **Maintenance and Repair**

The instrument modification or replaced parts supplied by any other supplier than authorized representative of Smar Equipamentos Industriais Ltda is prohibited and will void the Certification.

- **Marking Label**

Once a device labeled with multiple approval types is installed, do not reinstall it using any other approval types. Scratch off or mark unused approval types on the approval label.

- **For Ex-i protection application**

- Connect the instrument to a proper intrinsically safe barrier.

- Check the intrinsically safe parameters involving the barrier, equipment including the cable and connections.

- Associated apparatus ground bus shall be insulated from panels and mounting enclosures.

- When using shielded cable, isolate the not grounded cable end.
- Cable capacitance and inductance plus C_i and L_i must be smaller than C_o and L_o of the Associated Apparatus.

- **For Ex-d protection application**

- Only use Explosion Proof/Flameproof certified Plugs, Adapters and Cable glands.
- As the instrument is non-ignition capable under normal conditions, the statement “Seal Not Required” could be applied for Explosion Proof version regarding to electric conduits connection. (CSA Approved)
- In an Explosion-Proof/Flame-Proof installation, do not remove the instrument housing covers when powered on.

- **Electrical Connection**

In Explosion-Proof installations the cable entries must be connected through conduit with sealed unit or closed using metal cable gland or closed using metal blanking plug, all with at least IP66 and Ex-d certification. For enclosure with saline environment protection (W) and ingress protection (IP) applications, all NPT thread parts must apply a proper water-proof sealant (a non-hardening silicone group sealant is recommended).

- **For Ex-d and Ex-i protection application**

- The transmitter has a double protection. In this case the transmitter shall be fitted with appropriate certified cable entries Ex-d and the electric circuit supplied by a certified diode safety barrier as specified for the protection Ex-ia.

- **Environmental Protection**

- Enclosure Types (Type X): Supplementary letter X meaning special condition defined as default by Smar the following: Saline Environment approved - salt spray exposed for 200 hours at 35°C. (Ref: NEMA 250).
- Ingress protection (IP W): Supplementary letter W meaning special condition defined as default by Smar the following: Saline Environment approved - salt spray exposed for 200 hours at 35°C. (Ref: IEC60529).
- Ingress protection (IP x8): Second numeral meaning continuous immersion in water under special condition defined as default by Smar the following: 1 Bar pressure during 24hours. (Ref: IEC60529).

Hazardous Locations Certifications

NOTE
The IP68 sealing test (immersion) was performed at 1 bar for 24 hours. For any other situation, please consult Smar.

North American Certifications

FM Approvals (Factory Mutual)

Intrinsic Safety (FM 3014713)

IS Class I, Division 1, Groups A, B, C and D
IS Class II, Division 1, Groups E, F and G
IS Class III, Division 1

Explosion Proof (FM 3014713)

XP Class I, Division 1, Groups A, B, C and D

Dust Ignition Proof (FM 3014713)

DIP Class II, Division 1, Groups E, F and G
DIP Class III, Division 1

Non Incendive (FM 3014713)

NI Class I, Division 2, Groups A, B, C and D

Environmental Protection (FM 3014713)

Option: Type 4X/6/6P or Type 4/6/6P

Special conditions for safe use:

Entity Parameters Fieldbus Power Supply Input (report 3015629):
 $V_{max} = 24$ Vdc, $I_{max} = 250$ mA, $P_i = 1.2$ W, $C_i = 5$ nF, $L_i = 12$ uH
 $V_{max} = 16$ Vdc, $I_{max} = 250$ mA, $P_i = 2$ W, $C_i = 5$ nF, $L_i = 12$ uH
Temperature Class T4
Maximum Ambient Temperature: 60°C (-20 to 60 °C)

Overpressure Limits:
2000 psi for ranges 2, 3 and 4
4500 psi for range 5

Canadian Standards Association (CSA)

Certificate N: CSA1111005

Class 2258 02 Hazardous Locations for Class I, Division 1, Groups B, C and D; Class II, Division 1, Groups E, F and G; Class III, Division 1; Class I, Division 2, Groups A, B, C and D; Class II, Division 2, Groups E, F and G; Class III. FNICO Field Device Ex-n1 IIC T4.

Class 2258 04 Intrinsically Safe, Entity for Class I, Division 1, Groups A, B, C and D; Class II, Division 1, Groups E, F and G; Class III, Division 1. Intrinsically safe with entity parameters: $V_{max} = 24\text{ V}$ $I_{max} = 380\text{ mA}$ $C_i = 5\text{ nF}$ $L_i = 0\text{ uH}$ $P_i = 5.32\text{ W}$, when connected through CSA Certified Safety Barriers. FISCO Field Device Ex-ia IIC T4.

Ambient Temperature: $(-20^{\circ}\text{C} < T_{amb} < +40^{\circ}\text{C})$.

Enclosure Type 4 or Type 4X.

South American Certification

Certificate No: CEPEL 96.0075X

Intrinsic Safe - Ex-ia IIC T4/T5 EPL Ga

FISCO Field Device

• Parameters: $U_i = 30\text{ Vdc}$ $I_i = 380\text{ mA}$ $C_i = 5\text{ nF}$ $L_i = \text{neg}$ $P_i = 5.32\text{ W}$

Ambient Temperature: $-20^{\circ}\text{C} < T_{amb} < +65^{\circ}\text{C}$ for T4

$-20^{\circ}\text{C} < T_{amb} < +50^{\circ}\text{C}$ for T5

Certificate No: CEPEL 98.0054

Explosion Proof - Ex-d IIC T6 EPL Gb

Maximum Ambient Temperature: 40°C (-20 to 40°C).

Environment Protection: IP66 or IP66W.

Special conditions for safe use:

The certificate number ends with the letter "X" to indicate that for the version of Pressure Transmitter model LD293 equipped with housing made of aluminum alloy, only can be installed in "Zone 0" if is excluded the risk of occurs impact or friction between the housing and iron/steel itens.

The Essential Health and Safety Requirements are assured by compliance with:

ABNT NBR IEC 60079-0:2008 General Requirements

ABNT NBR IEC 60079-1:2009 Flameproof Enclosures "d"

ABNT NBR IEC 60079-11:2009 Intrinsic Safety "i"

ABNT NBR IEC 60079-26:2008 Equipment with equipment protection level (EPL) Ga

IEC 60079-27:2008 Fieldbus intrinsically safe concept (FISCO)

ABNT NBR IEC 60529:2005 Classification of degrees of protection provided by enclosures (IP Code)

European Certifications

Certificate No: NEMKO 13 ATEX 1574X

Explosion Proof: Group II, Category 2 G, Ex d, Group IIC, Temperature Class T6, EPL Gb

Ambient Temperature: -20 to 60°C

Certificate No: Nemko 13 ATEX 1574X

Environmental Protection: IP66W/68W

Special Conditions for Safe Use

Repairs of the flameproof joints must be made in compliance with the structural specifications provided by the manufacturer. Repairs must not be made on the basis of values specified in tables 1 and 2 of EN/IEC 60079-1

The Essential Health and Safety Requirements are assured by compliance with:

EN 60079-0:2012 General Requirements

EN 60079-1:2007 Flameproof Enclosures "d"

Certificate No: DMT 02 ATEX E 084

Intrinsic Safety

Group I, Category I M1, Ex ia, Group I, EPL Mb

Group II, Category 1/2 G, Ex ia, Group IIC, Temperature ClassT6, EPL Gb

FISCO Field Device

Supply circuit for the connection to an intrinsically safe for FISCO fieldbus circuit:

Ui = 24 Vdc, li = 380 mA, Pi = 5.32 W, Ci ≤ 5nF, Li = Neg

Parameter of the supply circuit comply with FISCO model according to EN 60079-27:2008

Ambient Temperature: -40°C ≤ Ta ≤ + 60°C

The Essential Health and Safety Requirements are assured by compliance with:

EN 60079-0:2009 General Requirements

EN 60079-11:2007 Intrinsic Safety “i”

EN 60079-26:2007 Equipment with equipment protection level (EPL) Ga

EN 60079-27:2008 Fieldbus intrinsically safe concept (FISCO)

Asia Certifications

Certificate No: Nepsi GYJ071320

Intrinsically safe - Ex ia, IIC

Temperature Class T4/T5/T6

Entity Parameters: Ui = 24 V li = 380 mA Ci = 5 nF Li = 0 Pi = 5.32 W

FISCO Field Device Ex ia IIC T4

Identification Plates and Control Drawing

Identification Plates

- Identification of Intrinsically Safe and Explosion Proof for gas and steam:

CEPEL

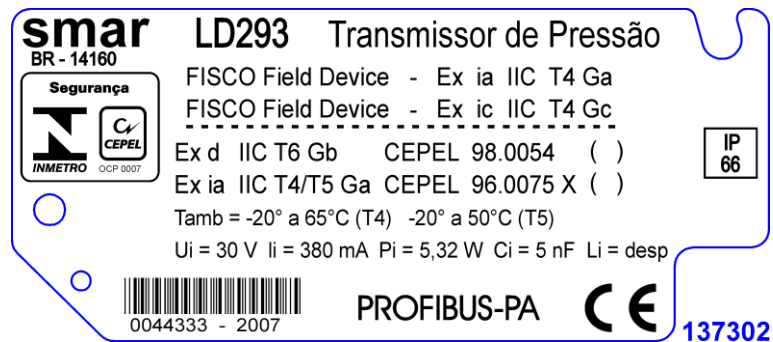

FM

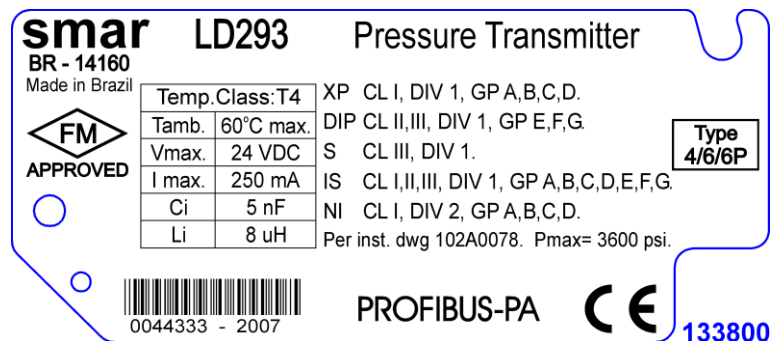

smar LD293 Pressure Transmitter
 NY - 11779
 Made in USA

Temp. Class: T4	XP CL I, DIV 1, GP A,B,C,D.
Tamb. 60°C max.	DIP CL II,III, DIV 1, GP E,F,G.
Vmax. 24 VDC	S CL III, DIV 1.
I max. 250 mA	IS CL I,II,III, DIV 1, GP A,B,C,D,E,F,G.
Ci 5 nF	NI CL I, DIV 2, GP A,B,C,D.
Li 8 uH	Per inst. dwg 102A0078. Pmax= 3600 psi.

FM APPROVED **Type 4/6/6P**

0044333 - 2007 **PROFIBUS-PA** **CE** **163600**

CSA

smar LD293 Pressure Transmitter
 BR - 14160

FISCO Field Device
 FNICO Field Device

CSA XP - CL I DIV 1 GR BCD, CL II DIV 1 GR EFG, CL III DIV 1
 NI - CL I DIV 2 GR ABCD
 IS - Exia - CL I DIV 1 GR ABCD, CL II DIV 1 GR EFG, CL III DIV 1
 Vmax=24V I max=380mA Ci=5nF Li=0
 T3C Ta=40°Cmax Inst. Dwg. 102A0608 Pmax=3600psi

SP **Type 4**
Dual Seal (process)
Seal not required (conduit)

0044333 - 2007 **PROFIBUS-PA** **CE** **143101**

NEMKO and DMT

smar LD293 Pressure Transmitter
 BR - 14160

FISCO Field Device - Ex ia IIC T4
 FNICO Field Device - Ex nL IIC T4

Ex II 1/2G Ex ia IIC T4/T5/T6 DMT 02 ATEX E 084 ()
 -40°C ≤ Ta ≤ +60°C
 Pi = 5,32 W Ui = 24 VDC li = 380 mA Li = neg Ci ≤ 5 nF
N II 2G Ex d IIC T6 Nemko 02 ATEX 149X ()

IP66
IP68 10m/24h

0044333 - 2007 **PROFIBUS-PA** **CE** **0470** **146201**

DMT

smar LD293 Pressure Transmitter
 BR - 14160

FISCO Field Device - Ex ia IIC T4
 FNICO Field Device - Ex nL IIC T4

Ex I M1 Ex ia I DMT 02 ATEX E 084
 -40°C ≤ Ta ≤ +60°C
 Pi = 5,32 W
 Ui = 24 VDC li = 380 mA Li = neg Ci ≤ 5 nF

IP 66

0044333 - 2007 **PROFIBUS-PA** **CE** **0470** **146400**

NEPSI

smar LD293 Pressure Transmitter
BR - 14160

NEPSI GYJ071320
FISCO Field Device - Ex ia IIC T4
EEx ia IIC T4/T5/T6
For the Tamb see certificate
Li = neg Ci = 5 nF
 $U_i = 16\text{ V}$ li = 250 mA Pi = 2,0 W T4

 IP 66

0044333 - 2007 PROFIBUS-PA  129200

WITHOUT APPROVAL



smar LD293 Pressure Transmitter
BR - 14160

0044333 - 2007 PROFIBUS-PA  155600

- Identification if Intrinsically Safe and Explosion Proof for saline atmospheres:

CEPEL

smar LD293 Transmissor de Pressão
BR - 14160

Segurança
 

FISCO Field Device - Ex ia IIC T4 Ga
FISCO Field Device - Ex ic IIC T4 Gc
Ex d IIC T6 Gb CEPEL 98.0054 ()
Ex ia IIC T4/T5 Ga CEPEL 96.0075 X ()
Tamb = -20° a 65°C (T4) -20° a 50°C (T5)
Ui = 30 V li = 380 mA Pi = 5,32 W Ci = 5 nF Li = desp

 IP 66W

0044333 - 2007 PROFIBUS-PA  125302

FM

smar LD293 Pressure Transmitter
BR - 14160
Made in Brazil

 Type 4X/6/6P

Temp. Class:	T4	XP	CL I, DIV 1, GP A,B,C,D.
Tamb.	60°C max.	DIP	CL II,III, DIV 1, GP E,F,G.
Vmax.	24 VDC	S	CL III, DIV 1.
I max.	250 mA	IS	CL I,II,III, DIV 1, GP A,B,C,D,E,F,G.
Ci	5 nF	NI	CL I, DIV 2, GP A,B,C,D.
Li	8 uH		Per inst. dwg 102A0078. Pmax= 3600 psi.

0044333 - 2007 PROFIBUS-PA  121500

smar LD293 Pressure Transmitter
 NY - 11779
 Made in USA

Temp. Class: T4	XP CL I, DIV 1, GP A,B,C,D.
Tamb. 60°C max.	DIP CL II,III, DIV 1, GP E,F,G.
Vmax. 24 VDC	S CL III, DIV 1.
I max. 250 mA	IS CL I,II,III, DIV 1, GP A,B,C,D,E,F,G.
Ci 5 nF	NI CL I, DIV 2, GP A,B,C,D.
Li 8 uH	Per inst. dwg 102A0078. Pmax= 3600 psi.

FM APPROVED

Type 4X/6/6P

0044333 - 2007 PROFIBUS-PA CE 163700

NEMKO and DMT

smar LD293 Pressure Transmitter
 BR - 14160

FISCO Field Device - Ex ia IIC T4
 FNICO Field Device - Ex nL IIC T4

II 1/2G Ex ia IIC T4/T5/T6 DMT 02 ATEX E 084 ()
 -40°C ≤ Ta ≤ +60°C
 Pi = 5,32 W Ui = 24 VDC li = 380 mA Li = neg Ci ≤ 5 nF

II 2G Ex d IIC T6 Nemko 02 ATEX 149X ()

IP66W
 IP68W 10m/24h

0044333 - 2007 PROFIBUS-PA CE 0470 151801

DMT

smar LD293 Pressure Transmitter
 BR - 14160

FISCO Field Device - Ex ia IIC T4
 FNICO Field Device - Ex nL IIC T4

I M1 Ex ia I DMT 02 ATEX E 084
 -40°C ≤ Ta ≤ +60°C
 Pi = 5,32 W
 Ui = 24 VDC li = 380 mA Li = neg Ci ≤ 5 nF

IP 66W

0044333 - 2007 PROFIBUS-PA CE 0470 152000

NEMKO and DMT

smar LD293 Pressure Transmitter
 BR - 14160
 Sertãozinho
 Brazil

FISCO Field Device - Ex ia IIC T4
 FNICO Field Device - Ex nL IIC T4

II 1/2G Ex ia IIC T4/T5/T6 Ga DMT 02 ATEX E 084 ()
 -40°C ≤ Ta ≤ +60°C
 Pi = 5,32 W Ui = 24 VDC li = 380 mA Li = neg Ci ≤ 5 nF

II 2G Ex d IIC T6 Gb Nemko 13 ATEX 1574X ()
 Tamb = -20°C to 60°C U = 28 VDC

IP66W
 IP68W 10m/24h

0000000 - 0000 PROFIBUS-PA CE 0470

Control Drawing

CSA

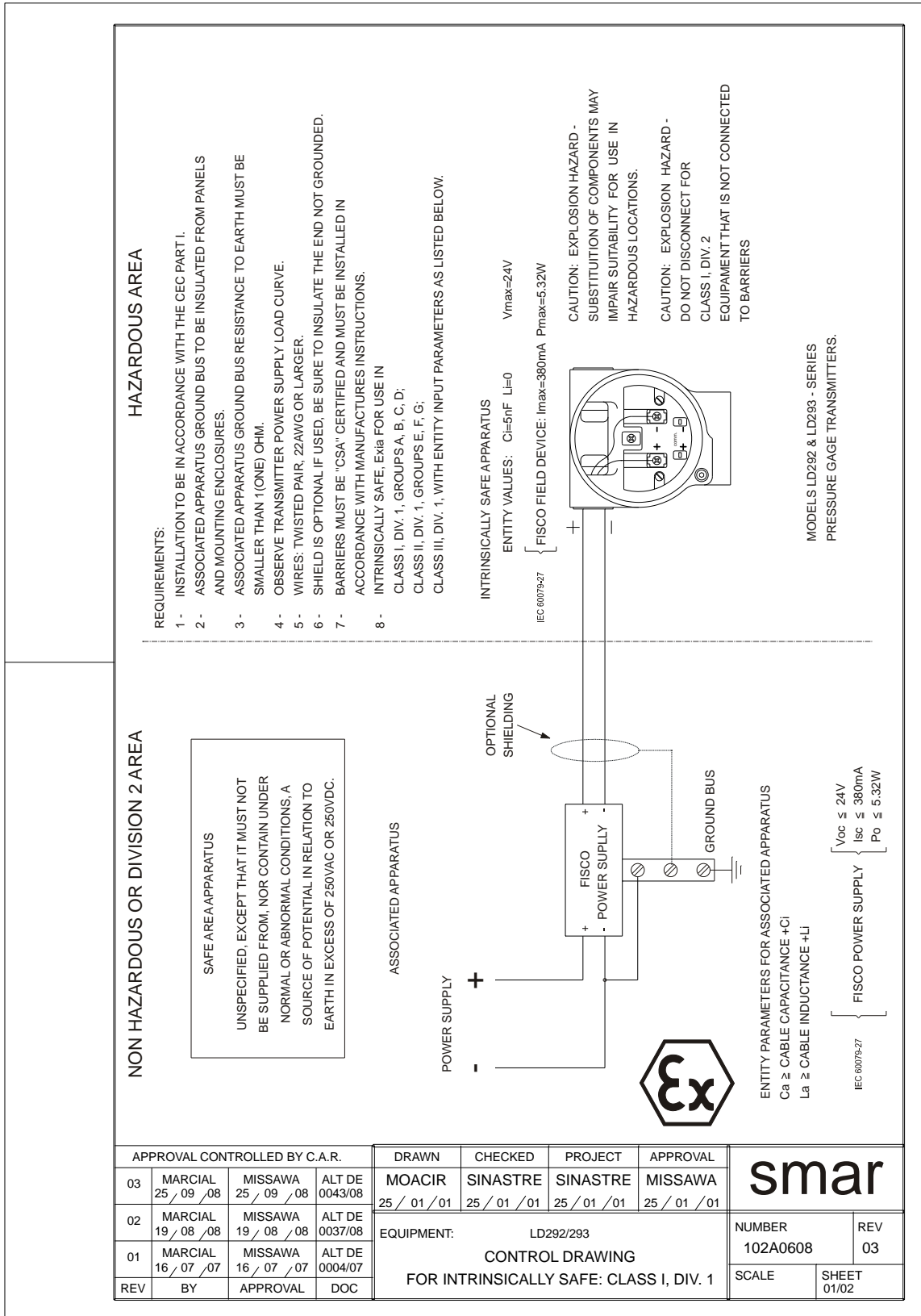

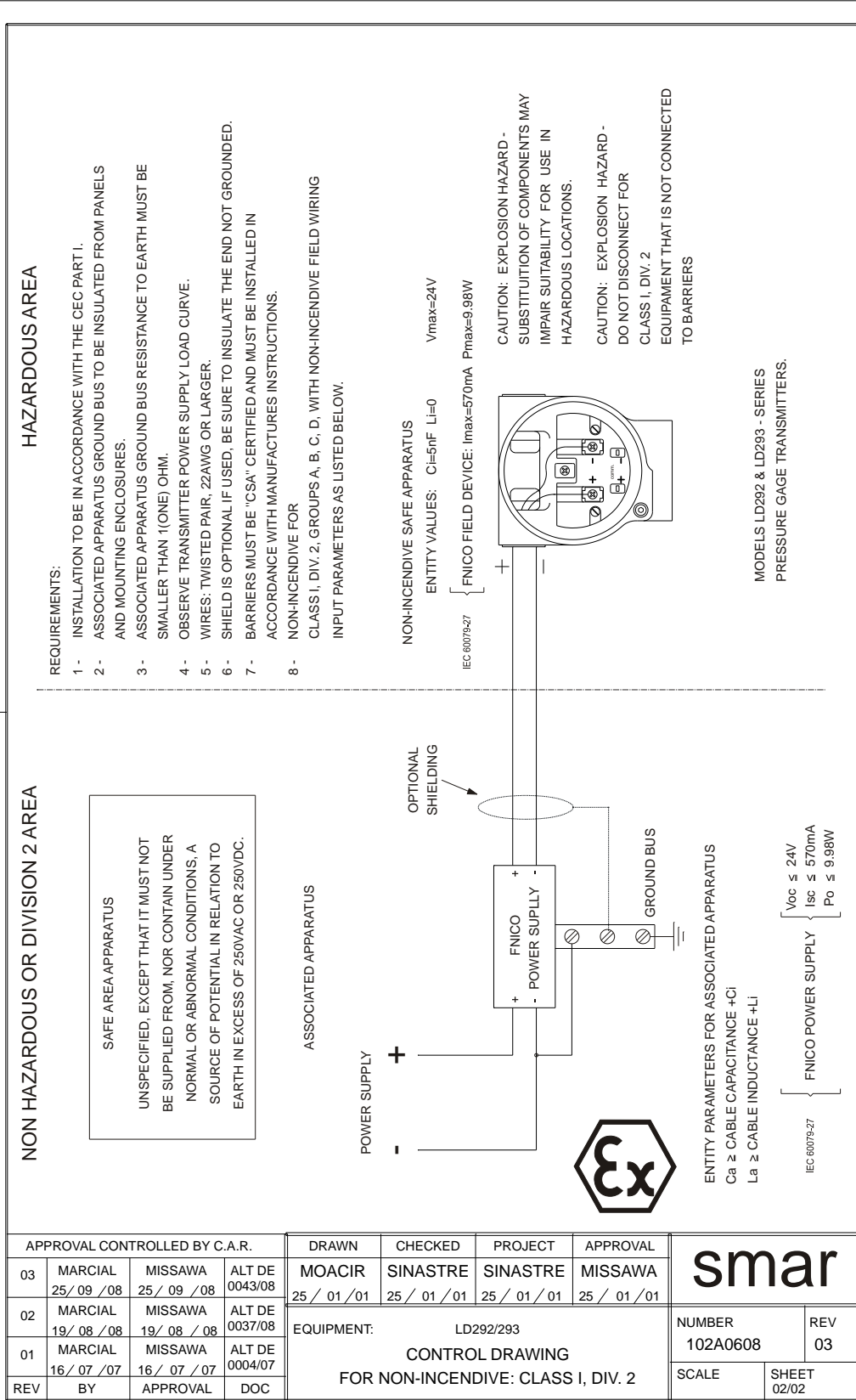

APPROVAL CONTROLLED BY C.A.R.				DRAWN	CHECKED	PROJECT	APPROVAL
03	MARCIAL 25/09/08	MISSAWA 25/09/08	ALT DE 0043/08	MOACIR 25/01/01	SINASTRE 25/01/01	SINASTRE 25/01/01	MISSAWA 25/01/01
02	MARCIAL 19/08/08	MISSAWA 19/08/08	ALT DE 0037/08	EQUIPMENT: LD292/293 CONTROL DRAWING FOR NON-INCENDIVE: CLASS I, DIV. 2			
01	MARCIAL 16/07/07	MISSAWA 16/07/07	ALT DE 0004/07				
REV	BY	APPROVAL	DOC				

NUMBER 102A0608	REV 03
SCALE	SHEET 02/02

Appendix B

		SRF – Service Request Form Pressure Transmitters				Proposal No.:	
Company:			Unit:		Invoice:		
COMMERCIAL CONTACT				TECHNICAL CONTACT			
Full Name:				Full Name:			
Function:				Function:			
Phone:		Extension:		Phone:		Extension:	
Fax:				Fax:			
Email:				Email:			
EQUIPMENT DATA							
Model:			Serial Number:		Sensor Number:		
Technology: () 4-20 mA () HART® () FOUNDATION fieldbus™ () PROFIBUS PA					Version Firmware:		
PROCESS DATA							
Process Fluid:							
Calibration Range		Ambient Temperature (°F)		Process Temperature (°F)		Process Pressure	
Min.:	Max.:	Min.:	Max.:	Min.:	Max.:	Min.:	Max.:
Static Pressure		Vacuum					
Min.:	Max.:	Min.:	Max.:				
Normal Operation Time:				Failure Date:			
FAILURE DESCRIPTION (Please, describe the observed behavior, if it is repetitive, how it reproduces, etc.)							
OBSERVATIONS							
USER INFORMATION							
Company:							
Contact:			Title:		Section:		
Phone:		Extension:		E-mail:			
Date:			Signature:				
For warranty or non-warranty repair, please contact your representative. Further information about address and contacts can be found on www.smar.com/contactus.asp .							

