

smar - Panel Interfaces

NOV / 2020
Panel
Interfaces

USER'S MANUAL

Panel Interfaces

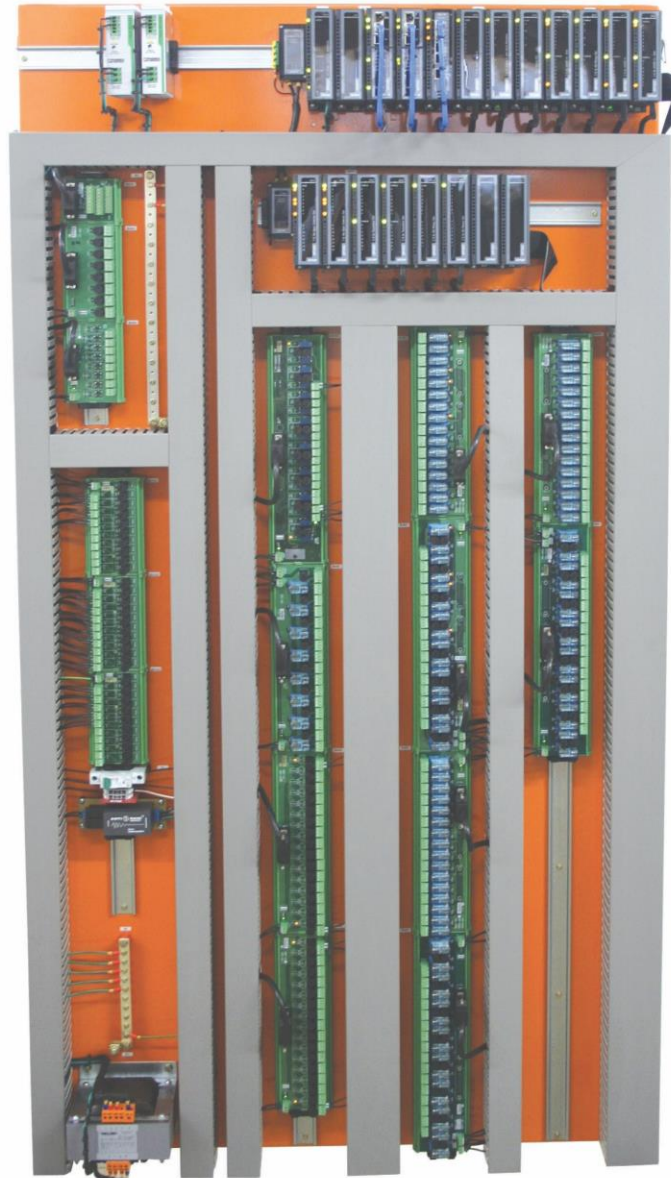

smar
NOVA SMAR S/A
www.smar.com.br

Specifications and information are subject to change without notice.
Up-to-date address information is available on our website.

web: www.smar.com/contactus.asp

PREVENTING ELECTROSTATIC DISCHARGE



WARNING

Electrostatic discharges can damage semiconductor electronic components present in printed circuit boards. In general, they occur when these components or the module connecting pins and racks are touched without the use of equipment to prevent electrostatic discharges.

The following procedures are recommend:

- ✓ Before handling the modules and racks, discharge the static electricity contained in the body through proper bracelets or even touching grounded objects.
- ✓ Avoid touching electronics components or rack and module connecting pins.

INTRODUCTION

Reducing the Panel Mounting Time

The panel mounting is reduced to a time fraction, in comparison to the traditional method. The cables are available with connectors suitable for interfaces and I/O modules. The interfaces increase the capacity of the I/O modules with terminal blocks, LED status indicators on the field, diagnostic, insulation circuit, over current protection and also increase the output capacity. Several cable sizes are available.

Reduction Wiring Errors

The system provides 100% pre-tested cables, allowing only the correct wire connection and eliminating the need of wire point-to-point check. With Smar interfaces there is a significant reduction in the panel mounting time if compared to traditional terminal blocks and prevent wiring errors, which can take several minutes to fix after the panel is ready.

Easy Maintenance and Troubleshooting

Normal terminal blocks may not offer the benefits of the interfaces, such as the field LED status indicator for each point. The new system facilitates the plant startup and troubleshooting and maintenance. Diagnoses like indications of burning fuses and field status LED allow to quickly locate failures and reduce the plant starting time and increase productivity.

Productivity Increase

With Smar interfaces the panel mounting time is shorter if compared to traditional terminal blocks. The ready cables eliminate costs and reduce cutting and connecting time, as well as routing and setting them in the conduits. Thus, engineering and assemblers need only to worry about one cable, instead of 20 conductors in the conventional process.

Simplifying the Panel Design

Engineering can simplify their panel drawings, specifying the interface and the cable, rather than specifying in detail the wire, cable markers, terminal block, accessories and their designs. The simplified designs not only help in the assembly, but also in maintenance.

Panel Visual Quality

The identification labels on the interface and the new cables organize the panel wiring and improve its aspect.

TABLE OF CONTENTS

INTERFACE MODULES	1.1
INTERFACE FOR 120/240 VAC 16 POINTS INPUT	1.3
ORDERING CODE	1.3
DESCRIPTION	1.3
TECHNICAL SPECIFICATIONS	1.3
INTERFACE FOR 24 VDC 16 POINTS INPUT	1.5
ORDERING CODE	1.5
DESCRIPTION	1.5
TECHNICAL SPECIFICATIONS	1.5
INTERFACE FOR 16 POINT AC PULSE INPUT	1.7
ORDERING CODE	1.7
DESCRIPTION	1.7
TECHNICAL SPECIFICATIONS	1.7
INTERFACE FOR 16 POINTS RELAY DIGITAL OUTPUT WITH NA AND NC CONTACT	1.9
ORDERING CODE	1.9
DESCRIPTION	1.9
TECHNICAL SPECIFICATIONS	1.9
INTERFACE FOR 16-POINT RELAY DIGITAL OUTPUT WITH NA AND NC CONTACT WITH FUSE	1.11
ORDERING CODE	1.11
DESCRIPTION	1.11
TECHNICAL SPECIFICATIONS	1.11
INTERFACE FOR 8-POINT ANALOG INPUT/OUTPUT	1.14
ORDERING CODE	1.14
DESCRIPTION	1.14
TECHNICAL SPECIFICATIONS	1.14
INTERFACE FOR 8-POINT ANALOG INPUT (LOW LEVEL/TEMPERATURE SIGNALS)	1.16
ORDERING CODE	1.16
DESCRIPTION	1.16
INTERFACE FOR 8-POINT ANALOG OUTPUT (VOLTAGE/CURRENT)	1.18
ORDERING CODE	1.18
DESCRIPTION	1.18
TECHNICAL SPECIFICATIONS	1.18
INTERFACE FOR 8-POINT DIGITAL OUTPUT RELAY WITH NA AND NF CONTACT WITH FUSE	1.20
ORDERING CODE	1.20
DESCRIPTION	1.20
TECHNICAL SPECIFICATIONS	1.20
10-POINT INTERFACE FOR POWER SUPPLY DISTRIBUTION	1.22
ORDERING CODE	1.22
DESCRIPTION	1.22
TECHNICAL SPECIFICATIONS	1.22
DIODE MATRIX INTERFACE	1.23
ORDERING CODE	1.23
DESCRIPTION	1.23
TECHNICAL SPECIFICATIONS	1.23
DIODE FOR DECOUPLING OF POWER SUPPLY FOR REDUNDANCY	1.24
ORDERING CODE	1.24
DESCRIPTION	1.24
TECHNICAL SPECIFICATIONS	1.24
INSTALLATION	1.25
INTERFACE FOR 16-POINT INPUT/OUTPUT DIGITAL 24 VDC	1.26
ORDERING CODE	1.26
DESCRIPTION	1.26
TECHNICAL SPECIFICATIONS	1.26
INTERFACE FOR 8-POINTS ANALOG INPUT/OUTPUT	1.29
ORDERING CODE	1.29
DESCRIPTION	1.29
TECHNICAL SPECIFICATIONS	1.29
INTERFACE FOR CD600PLUS	1.32
ORDERING CODE	1.32
TECHNICAL SPECIFICATIONS FOR ANALOG OUTPUT 8-POINT INTERFACE	1.33
TECNICAL SPECIFICATIONS FOR DIGITAL 8-INPUT INTERFACE	1.33

TECHNICAL SPECIFICATIONS FOR 24 VDC DIGITAL OUTPUT 8-POINT INTERFACE COMPATIBLE WITH NA AND NF CONTACT RELAY WITH FUSE FOR THE ITF-CD-A/C	1.34
SPART PART COMPONENTS	1.41
CONNECTION CABLES	1.41
ORDERING CODE	1.41
DESCRIPTION	1.41
TECHNICAL SPECIFICATIONS	1.42
BASIC RULES FOR PANEL MOUNTING	1.42
INSTALLATION CONDITION	1.42
DIMENSIONS	1.43

Section 1

INTERFACE MODULES

Interfaces make possible to eliminate the difficult work of making cables, attaching washers and assembling terminal blocks. Simply plug the interface in the DIN rail and connect the cable. It is easy and fast!

The Smar interfaces for panel are available with various features that will suit your application. They are designed for Smar I/O modules.

Here is a list of interfaces offered by Smar:

CODE	DESCRIPTION
ITF - 005AC1	Interface for 16 points of 120 Vac input compatible with M-005/DF15.
ITF - 005AC2	Interface for 16 points of 240 Vac input compatible with M-005/DF15.
ITF - 001	Interface for 16 points of 24 Vdc input compatible with M-001/DF11.
ITF - 005DC	Interface for 16 points of 24 Vdc input compatible with M-005/DF15.
ITF - 101	Interface for 16 points digital output for relay with NA and NC contact compatible M-101/DF21.
ITF - 101FAC	Interface for 16 points digital output for relay with NA and NC contact with fuse for AC load compatible with M-101/DF21.
ITF - 101FDC	Interface for 16 points digital output for relay with NA and NC contact with fuse for DC load compatible with M-101/DF21.
ITF - 102	Interface for 16 points digital output for relay with NA and NC contact compatible M-102/DF22.
ITF - 102FAC	Interface for 16 points digital output for relay with NA and NC contact with fuse for AC load compatible with M-102/DF22.
ITF - 102FDC	Interface for 16 points digital output relay for relay with NA and NC contact with fuse for DC load compatible with M-102/DF22.
ITF - 120AC	Interface for 8 points digital output for AC load relay compatible with M-120/DF25.
ITF - 120DC	Interface for 8 points digital output for DC load relay compatible with M-120/DF25.
ITF - 123-7	Interface for 16 points digital output for relay with NA and NC contact compatible for AC load with M-123/DF28 or M-127/DF69.
ITF - 1237FAC	Interface for 16 points digital output for relay with NA and NC contact with fuse for AC load compatible with M-123/DF28 or M-127/DF69.
ITF - 1237FDC	Interface for 16 points digital output for relay with NA and NC contact with fuse for DC load compatible with M-123/DF28 or M-127/DF69.
ITF - 304	Interface for 16 point AC pulse input compatible with M-304/DF67.
ITF - 401	Interface for 8 point analog input/output compatible with M-401-R/DF44, M-401-DR/DF57, DF116 and DF117.
ITF - 402	Interface for 8 point analog input (low level signal/temperature) compatible with M-402/DF45.
ITF - 501	Interface for 8 point analog output (voltage/current) compatible with M-501/DF46.
ITF - QDA-AC	Power distribution interface for 10 points 110/240 Vac @ 2A per point.
ITF - QDA-DC	Power distribution interface for 10 points 24 Vdc @ 2A per point.
ITF - D-12	Diode matrix Interface for 12 bulbs test.
ITF - DR	Diode for decoupling of power supply for redundancy.
ITF-DIG	Interface for 16 digital input/output points 24 Vdc.
ITF-AN-IOR	Interface for 8 analog input/output points compatible with DF113 and DF114.
ITF-CD-0	Interface for CD600 Plus, digital output without fuse.
ITF-CD-A	Interface for CD600 Plus, digital output with fuse, for AC load.
ITF-CD-D	Interface for CD600 Plus, digital output with fuse, for DC load.
ITF - C-10	Connection cable between LC700/DFI302 modules and ITF interfaces - 1.0 m.
ITF - C-15	Connection cable between LC700/DFI302 modules and ITF interfaces - 1.5 m.
ITF - C-20	Connection cable between LC700/DFI302 modules and ITF interfaces - 2.0 m.
ITF - C-25	Connection cable between LC700/DFI302 modules and ITF interfaces - 2.5 m.
ITF - C-30	Connection cable between LC700/DFI302 modules and ITF interfaces - 3.0m.
ITF - C-35	Connection cable between LC700/DFI302 modules and ITF interfaces - 3.5 m.
ITF - C-40	Connection cable between LC700/DFI302 modules and ITF interfaces - 4.0 m.
ITF - C-45	Connection cable between LC700/DFI302 modules and ITF interfaces - 4.5 m.
ITF - C-50	Connection cable between LC700/DFI302 modules and ITF interfaces - 5.0 m.
ITF-CDE-0	Connection cable between CD6000plus (left) and interfaces ITF - 0.5 m length.
ITF-CDE-1	Connection cable between CD6000plus (left) and interfaces ITF - 1.0 m length.
ITF-CDE-2	Connection cable between CD6000plus (left) and interfaces ITF - 1.5 m length
ITF-CDE-3	Connection cable between CD6000plus (left) and interfaces ITF - 2.0 m length

CODE	DESCRIPTION
ITF-CDE-4	Connection cable between CD6000plus (left) and interfaces ITF – 2.5 m length
ITF-CDE-5	Connection cable between CD6000plus (left) and interfaces ITF – 3.0 m length
ITF-CDE-6	Connection cable between CD6000plus (left) and interfaces ITF – 3.5 m length
ITF-CDE-7	Connection cable between CD6000plus (left) and interfaces ITF – 4.0 m length
ITF-CDE-8	Connection cable between CD6000plus (left) and interfaces ITF – 4.5 m length
ITF-CDE-9	Connection cable between CD6000plus (left) and interfaces ITF – 5.0 m length
ITF-CDD-0	Connection cable between CD6000plus (right) and interfaces ITF – 0.5 m length
ITF-CDD-1	Connection cable between CD6000plus (right) and interfaces ITF – 1.0 m length
ITF-CDD-2	Connection cable between CD6000plus (right) and interfaces ITF – 1.5 m length
ITF-CDD-3	Connection cable between CD6000plus (right) and interfaces ITF – 2.0 m length
ITF-CDD-4	Connection cable between CD6000plus (right) and interfaces ITF – 2.5 m length
ITF-CDD-5	Connection cable between CD6000plus (right) and interfaces ITF – 3.0 m length
ITF-CDD-6	Connection cable between CD6000plus (right) and interfaces ITF – 3.5 m length
ITF-CDD-7	Connection cable between CD6000plus (right) and interfaces ITF – 4.0 m length
ITF-CDD-8	Connection cable between CD6000plus (right) and interfaces ITF – 4.5 m length
ITF-CDD-9	Connection cable between CD6000plus (right) and interfaces ITF – 5.0 m length
ITF - CR-10	Connection cable between DFI302 R-Series modules and Interfaces ITF – 1.0 m length
ITF - CR-15	Connection cable between DFI302 R-Series modules and Interfaces ITF – 1.5 m length
ITF - CR-20	Connection cable between DFI302 R-Series modules and Interfaces ITF – 2.0 m length
ITF - CR-25	Connection cable between DFI302 R-Series modules and Interfaces ITF – 2.5 m length
ITF - CR-30	Connection cable between DFI302 R-Series modules and Interfaces ITF – 3.0 m length
ITF - CR-35	Connection cable between DFI302 R-Series modules and Interfaces ITF – 3.5 m length
ITF - CR-40	Connection cable between DFI302 R-Series modules and Interfaces ITF – 4.0 m length
ITF - CR-45	Connection cable between DFI302 R-Series modules and Interfaces ITF – 4.5 m length
ITF - CR-50	Connection cable between DFI302 R-Series modules and Interfaces ITF – 5.0 m length

Interface for 120/240 VAC 16 Points Input

Ordering Code

ITF - 005AC1 - Interface for 120 VAC 16 points input compatible with M-005/DF15.

ITF - 005AC2 - Interface for 240 VAC 16 points input compatible with M-005/DF15.

Description

This module reads the AC input tension and converts it to a logical true signal (ON) or false (OFF) 0 at 24 Vdc, compatible with the M-005/DF15 module inputs.

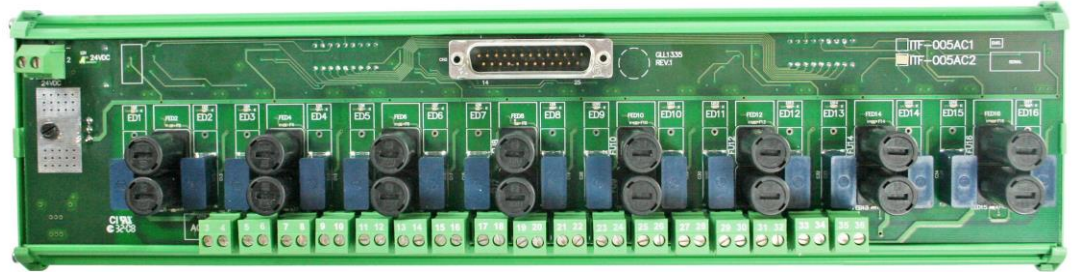

Figure 1 – Interface for the ITF Panel - 005AC2

Technical Specifications

ARCHITECTURE	
Input Number	16
ISOLATION	
Optical Isolation	5000 Vac
EXTERNAL SOURCE TO AC INPUT	
Input power supply	120 Vac (ITF - 005AC1) 240 Vac (ITF - 005AC2)
Typical per point consumption	10 mA
External source indication	Green LED
DC AUXILIARY SOURCE	
Input power supply	22 - 30 Vdc
Maximum consumption	220 mA : ITF-005AC1 540 mA : ITF-005AC2
External source indication	Green LED
Protection	Polarity
INPUT	
Voltage range for logical "1" level	100 – 140 Vac (ITF - 005AC1) 200 – 264 Vac (ITF - 005AC2)
Voltage range for logical "0" level	0 - 30 Vac (ITF - 005AC1) 0 - 50 Vac (ITF - 005AC2)
Typical current input	10 mA @ nominal voltage
Status indication	Yellow LED
VOLTAGE PROTECTION PROVIDED FOR SENSORS	
Fuse per input	100 mA
Burning fuse Indication *	Red LED

*For burning fuse indication the load must be connected.

INFORMATION SWITCHING	
Minimum voltage for a logic "1"	100 Vac (ITF - 005AC1), 45 to 60 Hz 200 Vac (ITF - 005AC2), 45 to 60 Hz
Maximum voltage for a logic "0"	30 Vac (ITF - 005AC1), 45 to 60 Hz 50 Vac (ITF - 005AC2), 45 to 60 Hz
Typical hysteresis	70 Vac (ITF - 005AC1) 150 Vac (ITF - 005AC2)
"0" to "1" response time	5 ms
"1" to "0" response time	42 ms

FIELD CONNECTION
Two terminals up to two-wire input (1,5 mm ²).

MECHANICAL INFORMATION	
Mounting	DIN rail
Dimensions (L x W x H)*	(347 x 89.6 x 70) mm

*For more details see Figure 26.

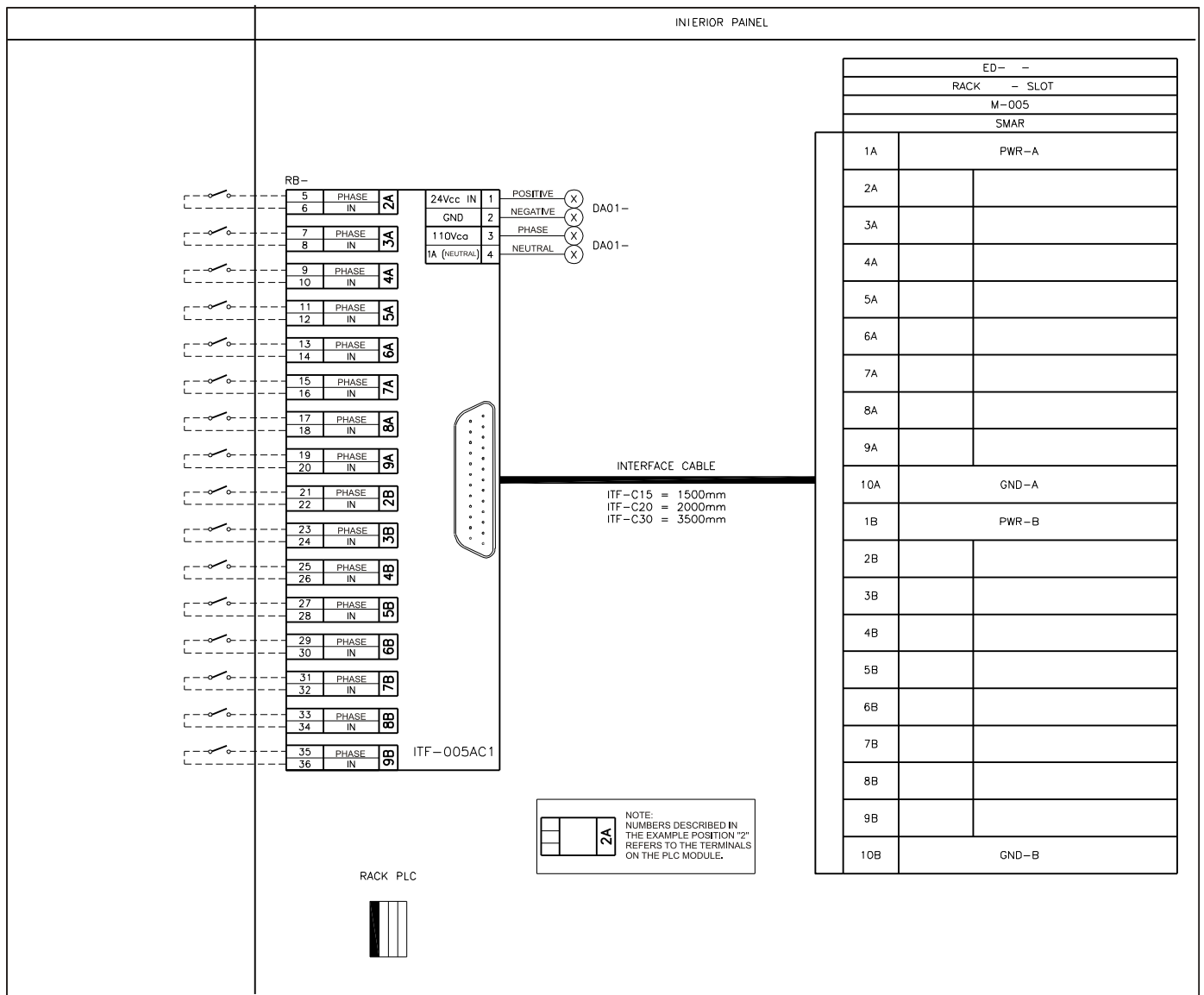

Figure 2 – ITF-005AC1 Interconnection Diagram

Interface for 24 Vdc 16 Points Input

Ordering Code

ITF - 001 - Interface for 24 Vdc 16 points input compatible with M-001/DF11

ITF - 005DC - Interface for 24 Vdc 16 points input compatible with M-005/DF15

Description

Interface has 16 DC digital inputs compatible with the M-001/DF11 and M-005/DF15.

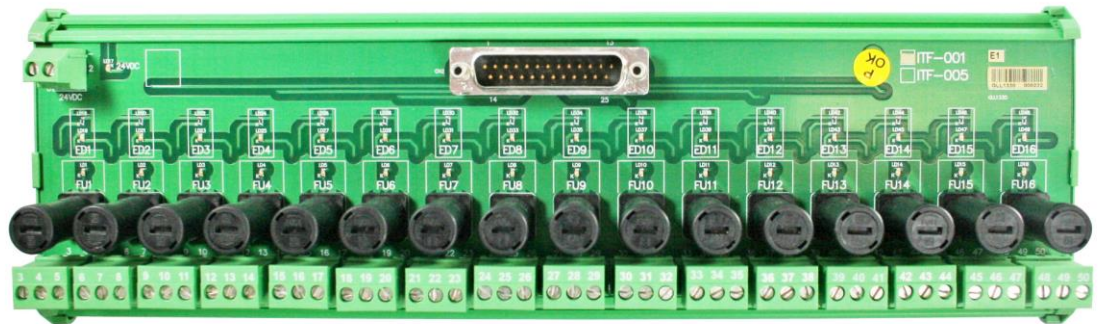

Figure 3 – ITF – 001 Interface for Panel

Technical Specifications

ARCHITECTURE	
Input Number	16

DC AUXILIARY SOURCE	
Input power supply	22 - 30 Vdc
Maximum consumption	200 mA @ 24 Vdc
External source indication	Green LED
Protection	Polarity

VOLTAGE PROTECTION PROVIDED FOR SENSORS	
Fuse per input	100 mA
Burning fuse indication*	Red LED

* For burning fuse indication the load must be connected.

INPUTS	
Per-point input current	8 mA @ 24 Vdc
Status indication	Yellow LED

CONNECTION FOR FIELD	
2 terminal blocks providing power to the sensor (positive and negative) and 1 for each input.	
Up to 2 wires (1.5 mm ²) per terminal.	

MECHANICAL INFORMATION	
Mounting	DIN rail
Dimensions (L x W x H)*	(290 x 89.6 x 70) mm

* For more details see Figure 40.

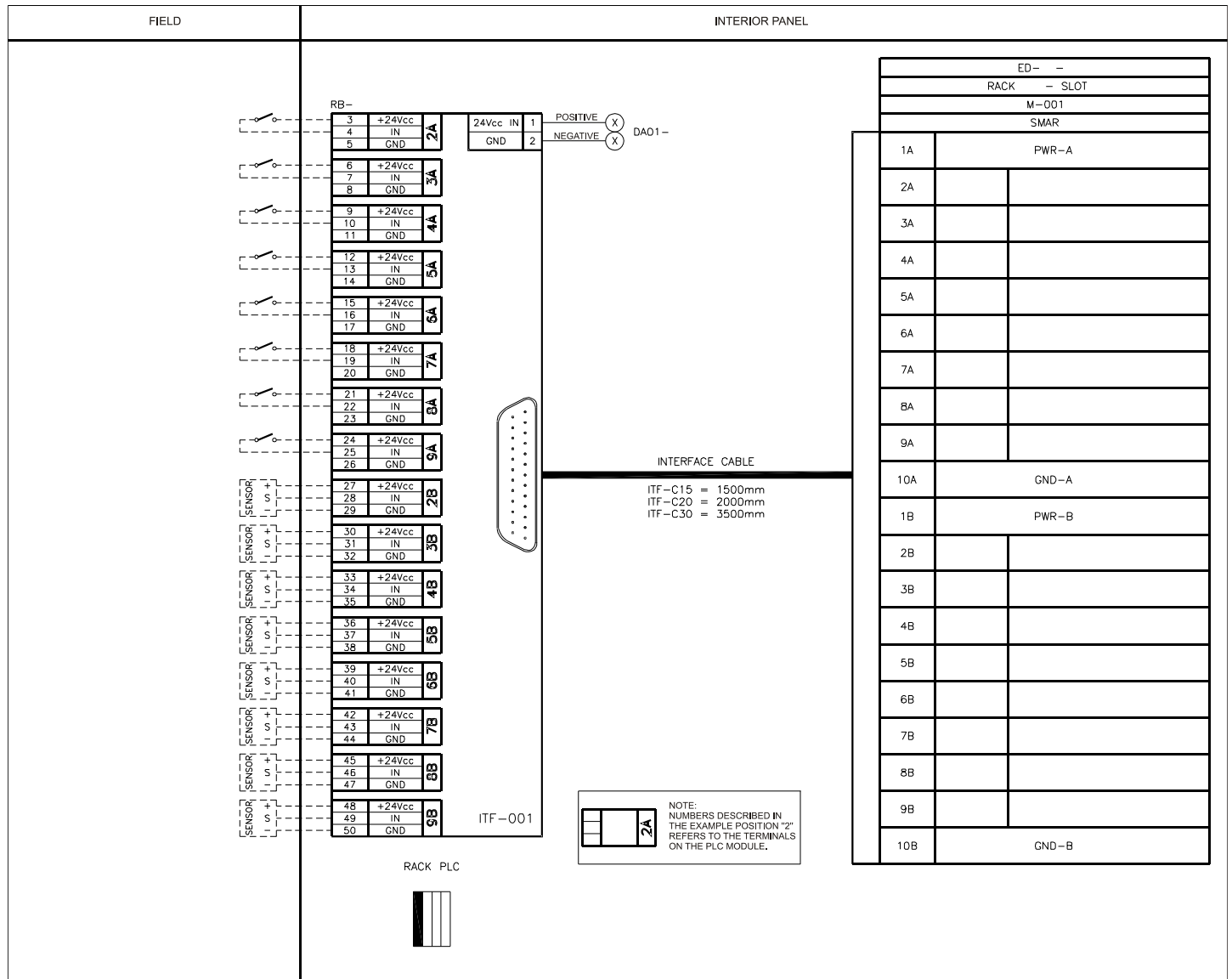

Figure 4 – ITF-001 Interconnection Diagram

Interface for 16 Point AC Pulse Input

Ordering Code

ITF - 304 - Interface for 16 point AC pulse input compatible with M-304/DF67.

Description

Interface has 16 AC pulse inputs compatible with the M-304/DF67.

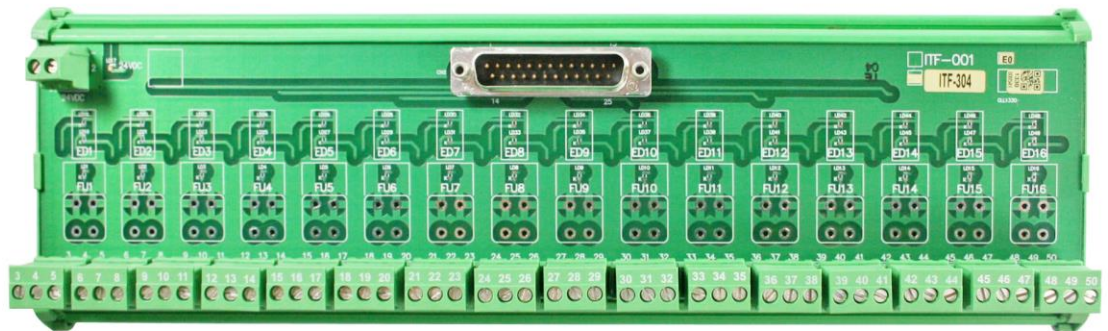

Figure 5 – ITF-304 Interface for Panel

Technical Specifications

ARCHITECTURE	
Input Number	16

DC AUXILIARY SOURCE	
Input power supply	22 - 30 Vdc
Maximum consumption	200 mA @ 24 Vdc
External source indication	Green LED
Protection	Polarity

CONNECTION FOR FIELD	
2 terminal blocks providing power to the sensor (positive and negative) and 1 for each input.	
Up to 2 wires (1.5 mm ²) per terminal.	

MECHANICAL INFORMATION	
Mounting	DIN rail
Dimensions (L x W x H)*	(290 x 89.6 x 70) mm

* For more details see Figure 40.

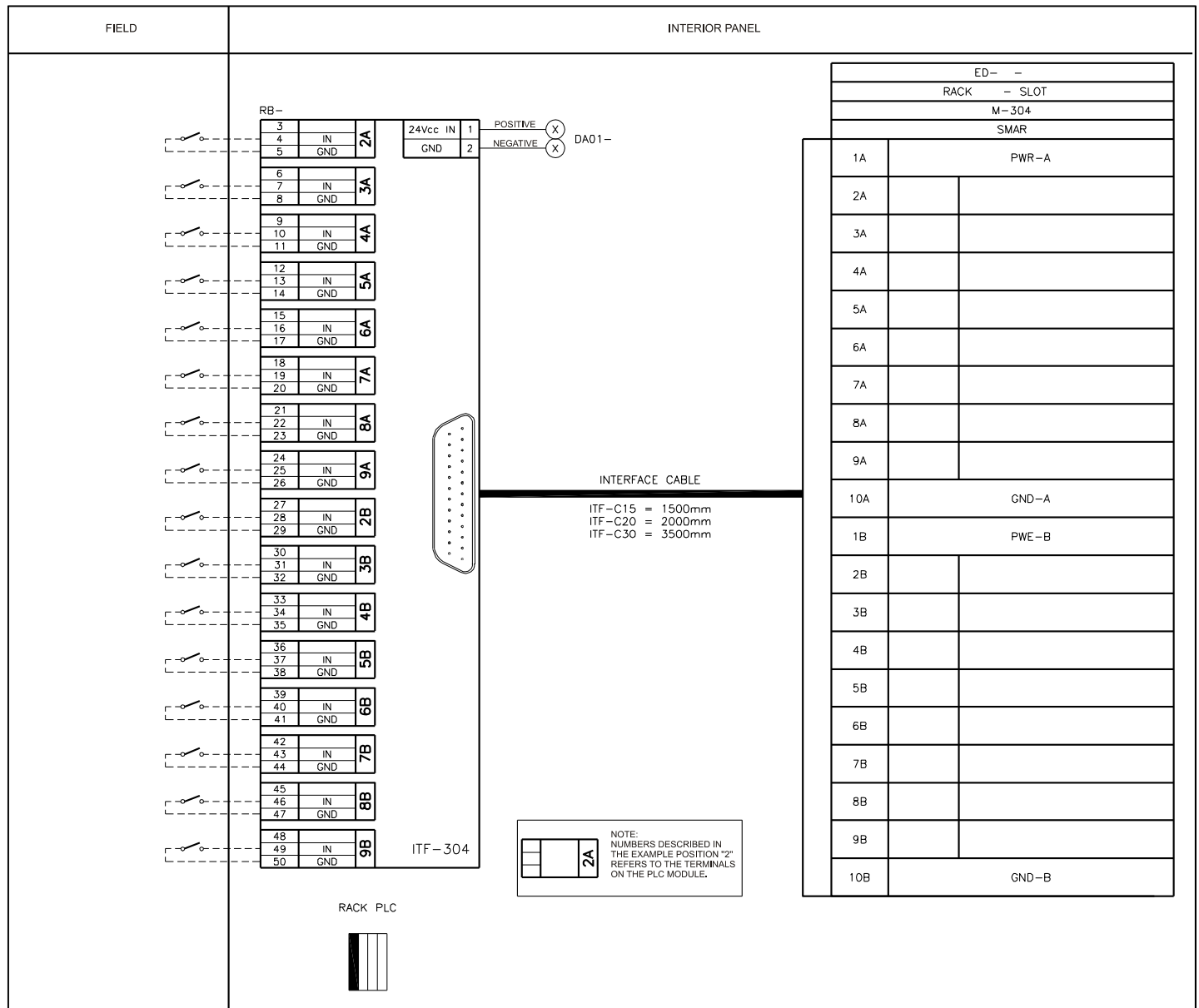

Figure 6 – ITF-304 Interconnection Diagram

Interface for 16 Points Relay Digital Output with NA and NC Contact

Ordering Code

ITF - 101 - Interface for 16-point digital output relay with NA and NC compatible with M-101/DF21.
 ITF - 102 - Interface for 16-point digital output relay with NA and NC compatible with M-102/DF22.
 ITF - 123-7 - Interface for 16-point digital output relay with NA and NC compatible with M-123/DF28, M-127/DF69.

Description

This interface connects the outputs of the modules corresponding to the relay coil.



Figure 7 – ITF-123-7 Interface Panel

Technical Specifications

ARCHITECTURE	
Output Number	16
DC AUXILIARY SOURCE	
Power supply source	20 - 30 Vdc
Maximum current	450 mA @ 24 Vdc: ITF-101 500 mA @ 24 Vdc: ITF-102 530 mA @ 24 Vdc: ITF-123-7
Indication	Green LED
Protection	Polarity
OUTPUTS	
1 NA contact , 1 NF contact, 3 terminals / output	1 NA contact , 1NF contact
Vac range	20 – 250 Vac
Vdc range	20 – 110 Vdc
Maximum current for 250 Vac	2 A (resistive); 2 A (inductive)
Maximum current for 30 Vdc	2 A (resistive); 2 A (inductive)
Leakage	No M-127: 500 µA @ 100 Vac
Overload protection per output	Must be provided externally
Operation time	10 ms (maximum)
Mechanical Life - switching cycles	20.000.000 operations (min.) @ current (max).
Status indication	Yellow LED
Relay Sockets	Yes

CONNECTION FOR FIELD	
3 terminal: common, NC and NO.	
Up to 2 wires (1.5 mm ²) per terminal.	

MECHANICAL INFORMATION	
Mounting	DIN rail
Dimensions (L x W x H)*	(290 x 89.6 x 70) mm

* For more details see Figure 40.

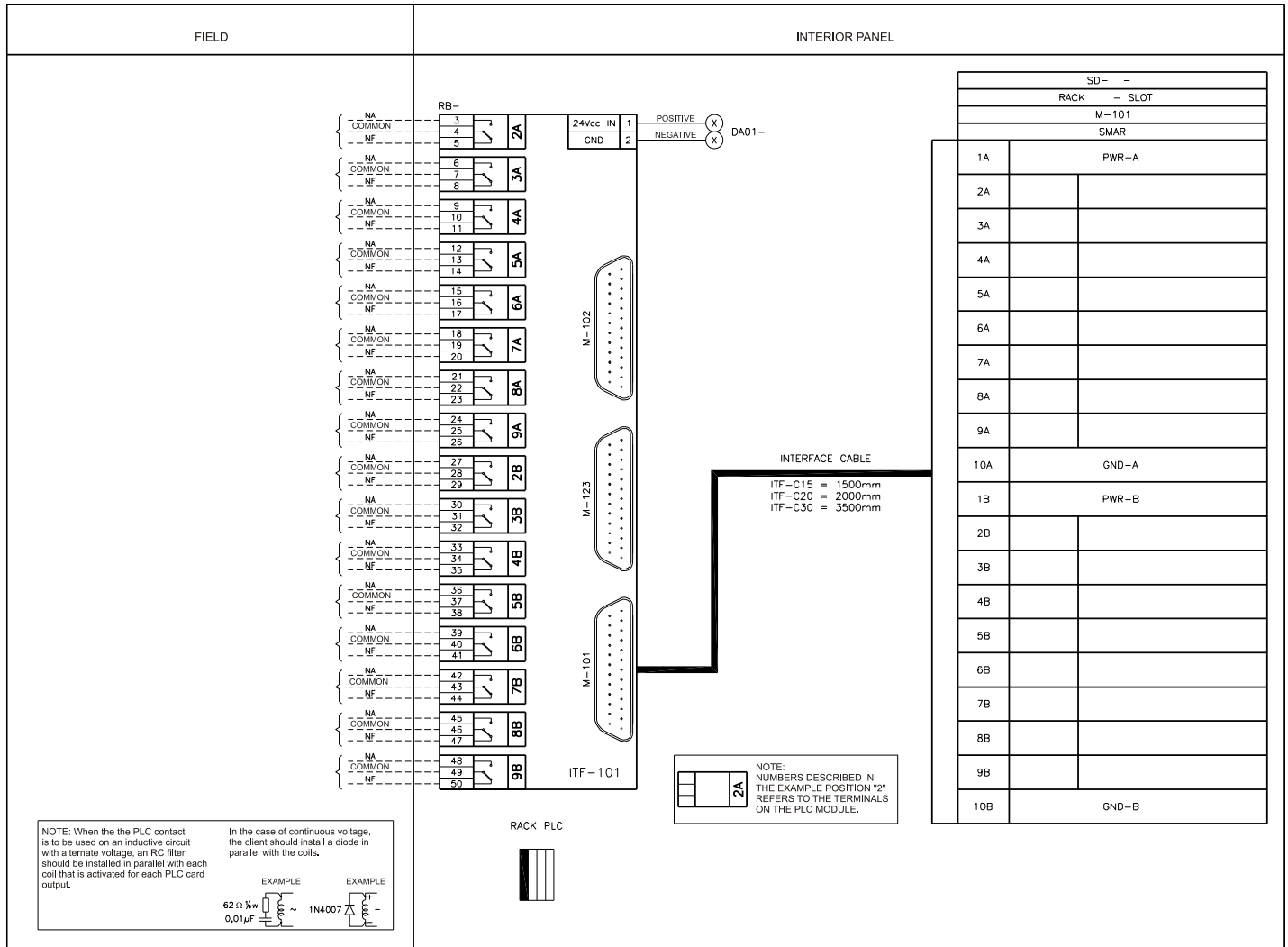

Figure 8 – ITF-101 Interconnection Diagram

Interface for 16-point Relay Digital Output with NA and NC Contact with Fuse

Ordering Code

- ITF - **101FAC** - Interface for 16-point relay digital output with NA and NC with fuse for AC load compatible with M-101/DF21
- ITF - **101FDC** - Interface for 16-point relay digital output with NA and NC with fuse for DC load compatible with M-101/DF21
- ITF - **102FAC** - Interface for 16-point relay digital output with NA and NC with fuse for AC load compatible with M-101/DF22
- ITF - **102FDC** - Interface for 16-point relay digital output with NA and NC with fuse for DC load compatible with M-102/DF22
- ITF - **1237FAC** - Interface for 16-point relay digital output with NA and NC with fuse for AC load compatible with M-123/DF28, M-127/DF69
- ITF - **1237FDC** - Interface for 16-point relay digital output with NA and NC with fuse for DC load compatible with M-123/DF28, M-127/DF69

Description

This interface connects the outputs of the modules corresponding to the relay coil.

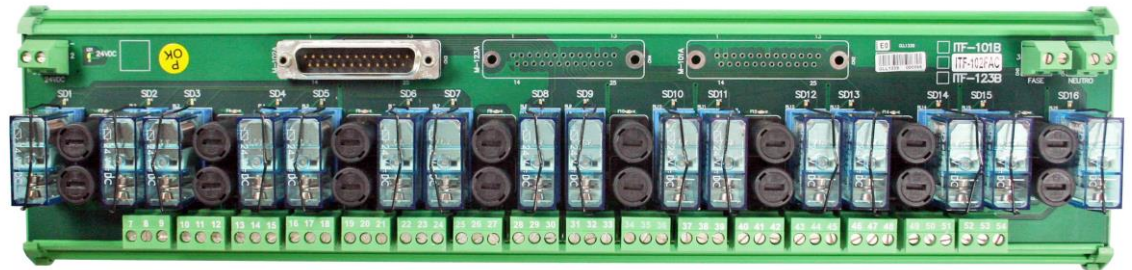

Figure 9 – ITF-102FAC Interface Panel

Technical Specifications

ARCHITECTURE	
Output Number	16
DC AUXILIARY SOURCE	
Power Supply	20 - 30 Vdc
Maximum Current	ITF - 101FAC/DC: 420 mA @ 24 Vdc ITF - 102FAC/DC: 480 mA @ 24 Vdc ITF - 1237FAC/DC: 550 mA @ 24 Vdc
Indication	Green LED
Protection	Polarity

OUTPUTS	
1 NA contact , 1 NF contact, 3 terminals / output	1 NA contact , 1NF contact
Vac range	20 – 250 Vac
Vdc range	20 – 110 Vdc
Maximum current for 250 Vac	2 A (resistive); 2 A (inductive)
Maximum current for 30 Vdc	2 A (resistive); 2 A (inductive)
Leakage	No
Overload protection per output	Fuse (2A)
Burning fuse indication *	Red LED
Operation time	10 ms (maximum)
Mechanical Life - switching cycles	20.000.000 operations (min.) @ current (max).
Status indication	Yellow LED
Relay sockets	Yes

*For burning fuse indication the load must be connected.

CONNECTION FOR FIELD
3 terminals: common, NC and NO.
Up to 2 wires (1.5 mm ²) per terminal.

MECHANICAL INFORMATION	
Mounting	DIN rail
Dimensions (L x W x H)*	(290 x 89.6 x 70) mm

* For more details see Figure 40.

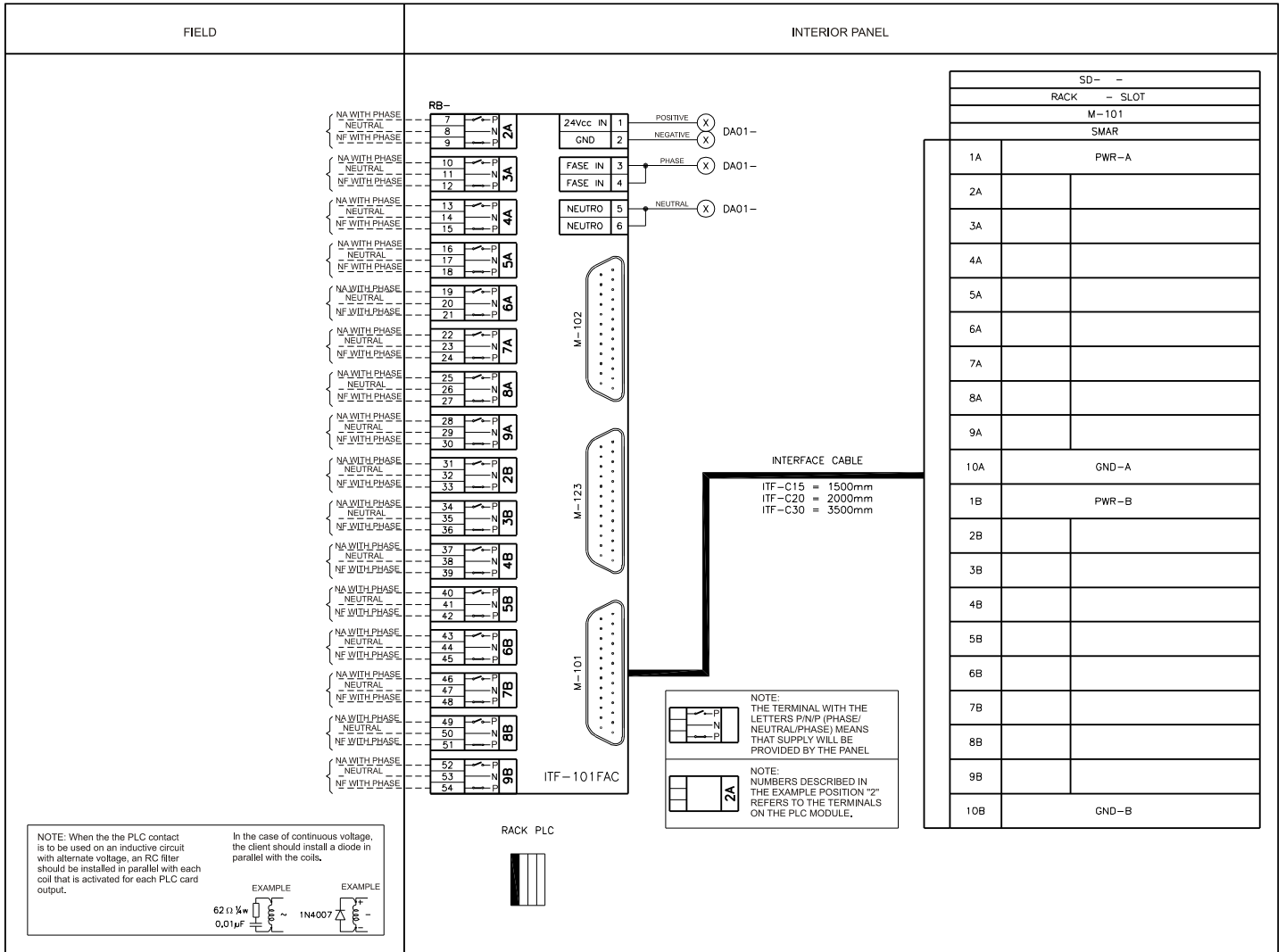

Figure 10 – ITF-101-FAC Interconnection Diagram

Interface for 8-point Analog Input/Output

Ordering Code

ITF - 401 - Interface for 8-point analog input/output compatible with M-401-R/DF44, M-401-DR/DF57, DF116 e DF117.

Description

The interface has 8-point analog input/output points to connect to M-401R/DF44, M-401-DR/DF57, DF116 e DF117.

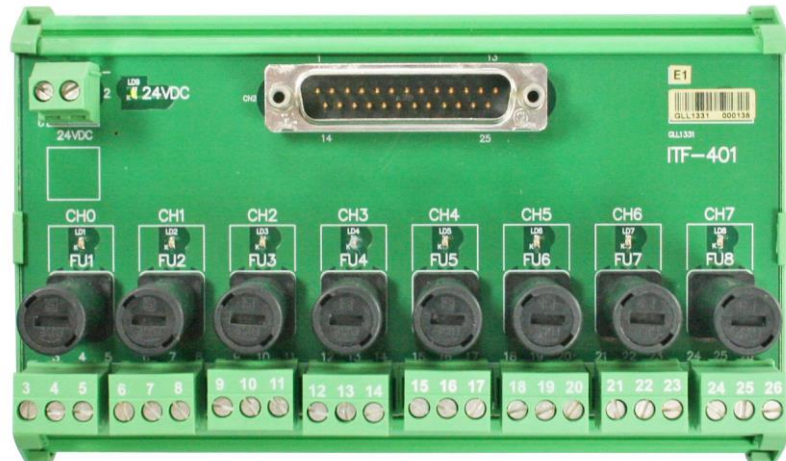

Figure 11 – ITF-401 Interface Panel

Technical Specifications

DC AUXILIARY SOURCE	
External source	20 – 30 Vdc (output) 22 - 30 Vdc (input)
Maximum consumption	200 mA @ 24 Vdc
Indication	Green LED
Protection	Polarity

INPUTS/OUTPUTS	
Current per point	22 mA @ 24 Vdc

VOLTAGE PROTECTION PROVIDED FOR SENSORS	
Fuse per point	100 mA
Burning fuse Indication *	Red LED

*For burning fuse indication the load must be connected.

CONNECTION FOR FIELD	
3 terminals: common, NC and NO.	
Up to 2 wires (1.5 mm ²) per terminal.	

MECHANICAL INFORMATION	
Mounting	DIN rail
Dimensions (L x W x H)*	(146 x 89.6 x 70) mm

* For more details see Figure 40.

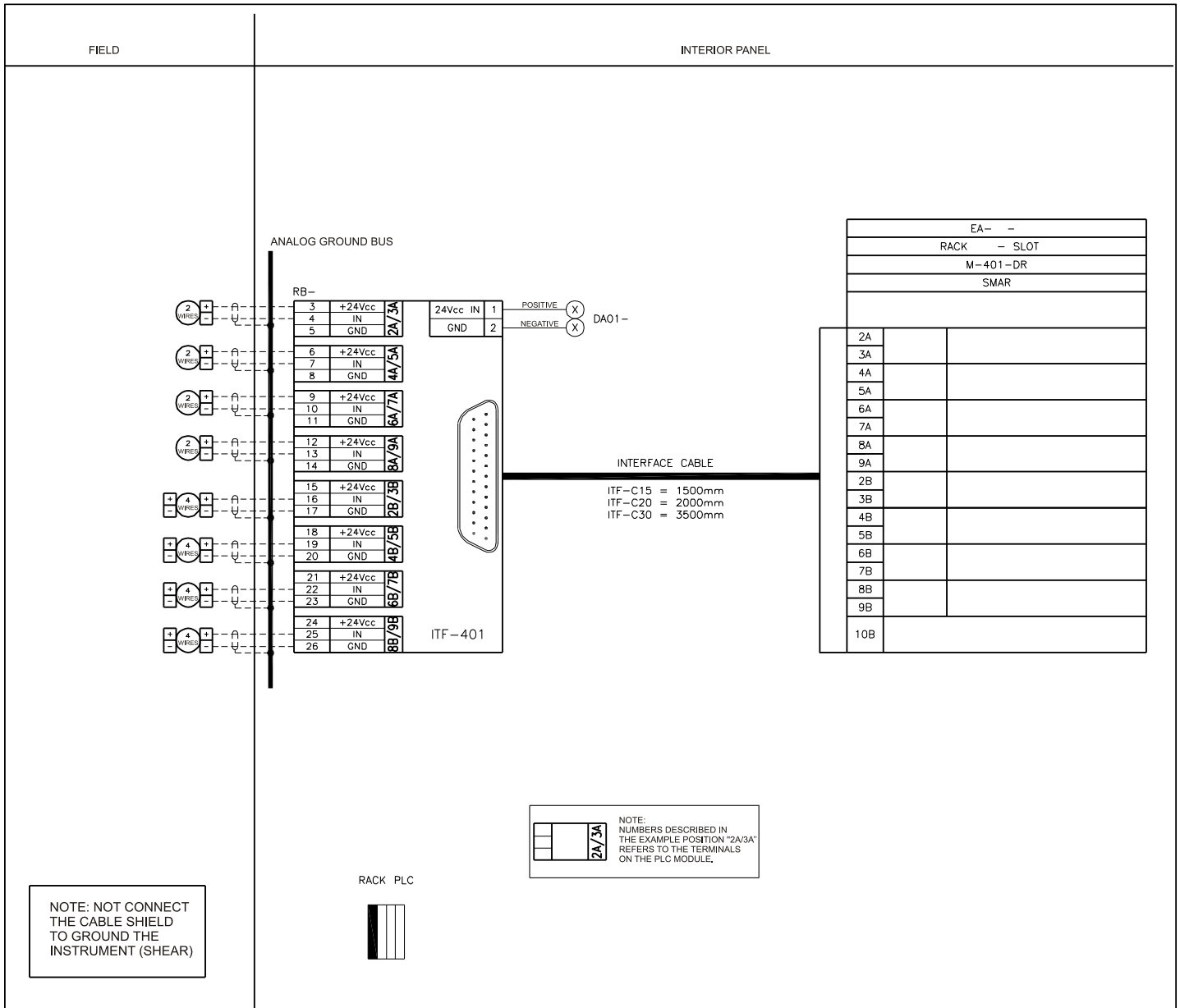

Figure 12 – ITF-401 Interconnection Diagram

Interface for 8-Point Analog Input (Low Level/Temperature Signals)

Ordering Code

ITF - 402 - Interface for 8-point analog input (low level/temperature) compatible with M-402/DF45.

Description

The interface has 8-point analog input to connect to M-402/DF45.

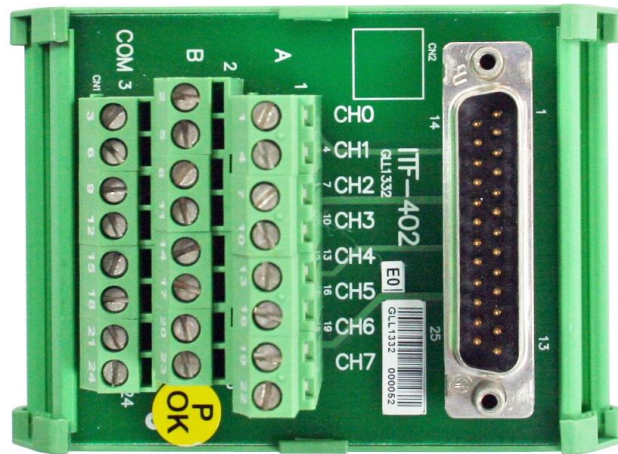

Figure 13 – ITF-402 Interface Panel

CONNECTION FOR FIELD	
Up to 2 wires (1.5 mm ²), 3 terminals per input.	
MECHANICAL INFORMATION	
Mounting	DIN rail
Dimensions (L x W x H)*	(290 x 89.6 x 70) mm

* For more details see Figure 40.

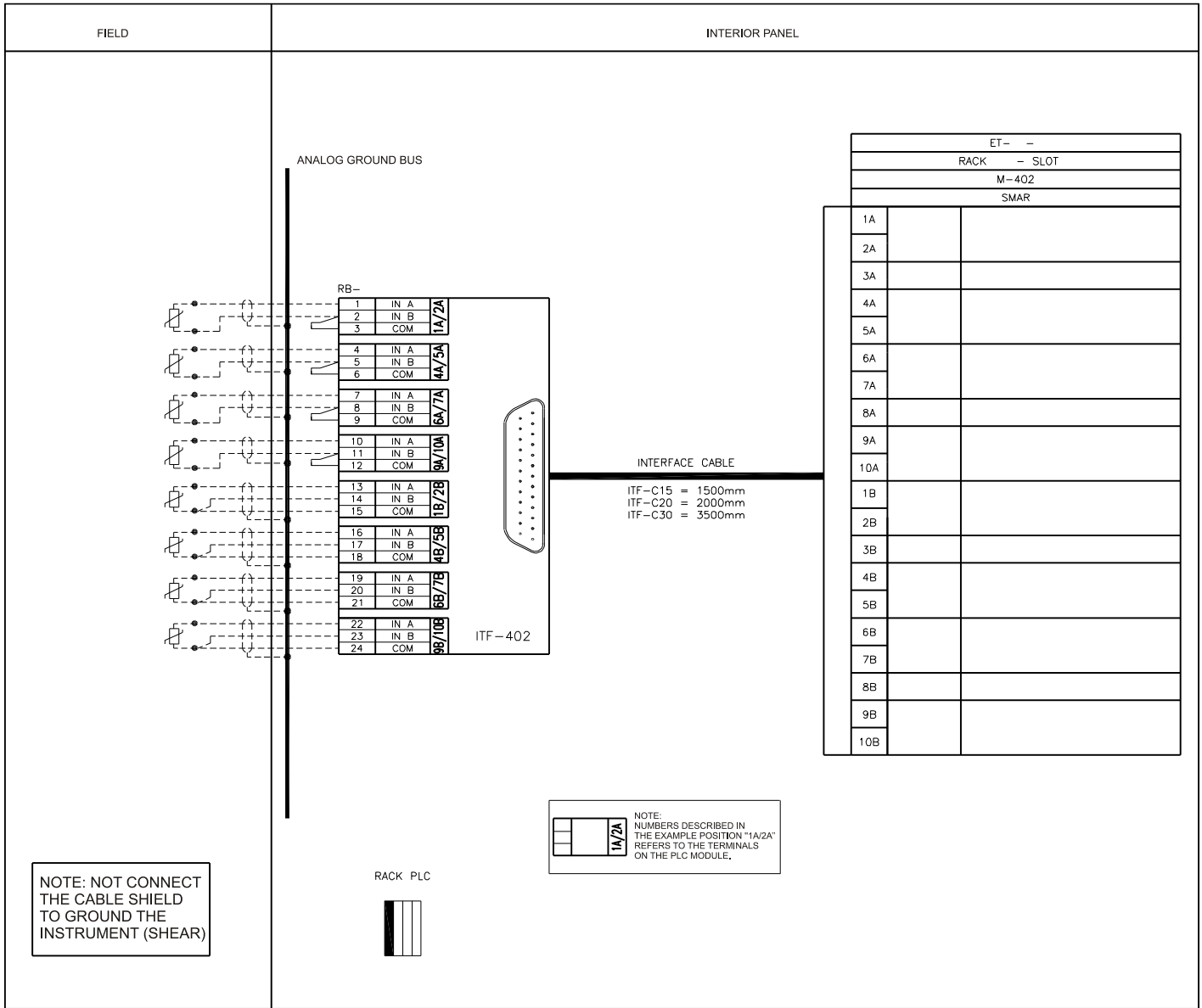

Figure 14 – ITF-402 Interconnection Diagram

Interface for 8-Point Analog Output (Voltage/Current)

Ordering Code

ITF - 501 - Interface for 8-point analog output (voltage/current) compatible with M-501/DF46.

Description

The interface has 8-point analog output to connect to M-501/DF46.

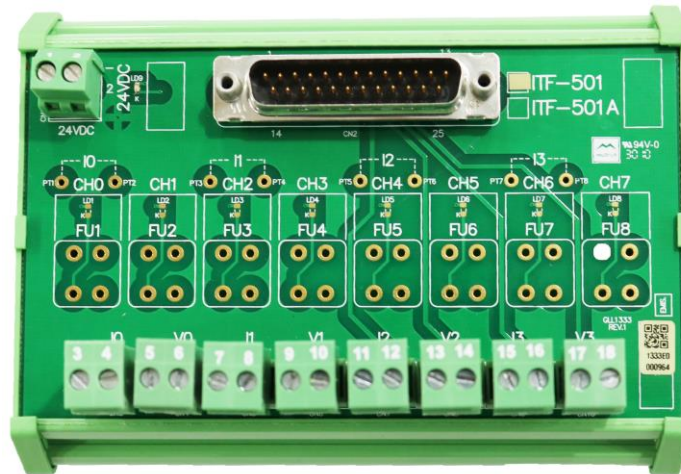

Figure 15 – ITF-501 Interface Panel

Technical Specifications

ARCHITECTURE	
Output Number	8
DC AUXILIARY SOURCE	
“In Rush” Current	2,3 A, 10ms (maximum) @ 24 Vdc
External Source	20 - 30 Vdc
Maximum Current	200 mA
Indication	Yes
Protection	Polarity
OUTPUTS	
Posts	Two terminals for each output.
Diode to measure the output current	Yes, in the current outputs
CONNECTION FOR FIELD	
Up to 2 wires (1.5 mm ²), 3 terminals per input.	
MECHANICAL INFORMATION	
Mounting	DIN rail
Dimensions (L x W x H)*	(290 x 89.6 x 70) mm

* For more details see Figure 40.

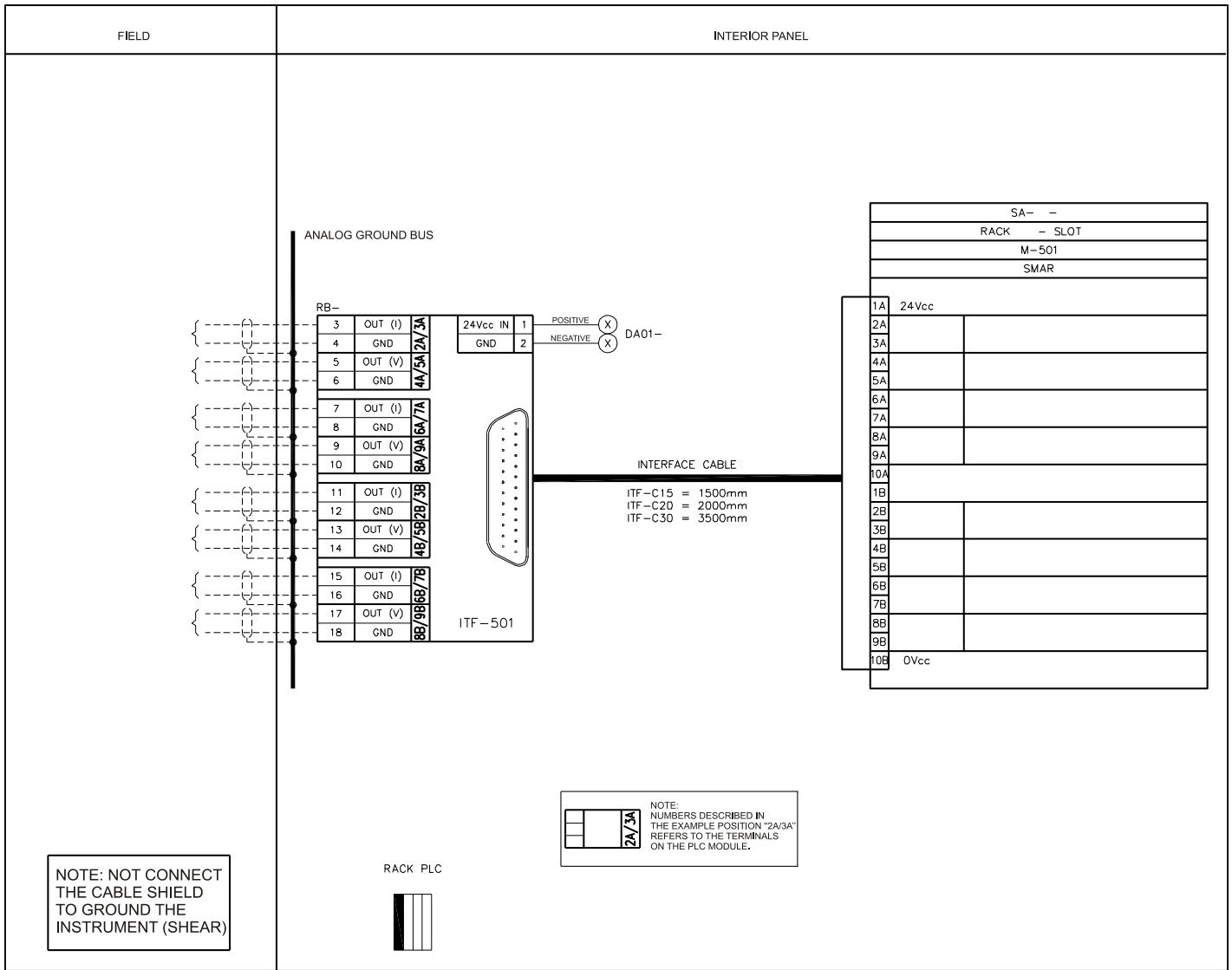

Figure 16 – ITF-501 Interconnection Diagram

Interface for 8-Point Digital Output Relay with NA and NF Contact with Fuse

Ordering Code

ITF - 120FAC - Interface for 8-point digital output relay to AC load compatible with M-120/DF25.
 ITF - 120FDC - Interface to 8-point digital output relay to AC load compatible with M-120/DF25.

Description

This interface connects the M-120/DF25 module outputs to the relay coil.



Figure 17 – ITF-120 Interface Panel

Technical Specifications

ARCHITECTURE	
Output Number	8

DC AUXILIARY SOURCE	
Power Supply	20 – 30 Vdc
Maximum Current	280 mA @ 24 Vdc
Indication	Green LED
Protection	Polarity

OUTPUTS	
2 NA contact posts – per output	2 NA contact, 2 NF contact, 2 commons
Vac range	20 – 250 Vac
Vdc range	20 – 110 Vdc
Maximum current for 250 Vac	2 A (resistive); 2 A (inductive)
Maximum current for 30 Vdc	2 A (resistive); 2 A (inductive)
Leakage	No M-127: 500 µA @ 100 Vac
Overload protection per output	Fuse (2A)
Burning fuse indication *	Red LED
Operation time	10 ms (maximum)
Mechanical Life - switching cycles	20.000.000 operations (min.) @ current (max).
Status indication	Yellow LED
Relay socket	Yes

*For burning fuse indication the load must be connected.

CONNECTION FOR FIELD
Up to 2 wires (1.5 mm ²), 3 terminals per input.

MECHANICAL INFORMATION	
Mounting	DIN rail
Dimensions (L x W x H)*	(290 x 89.6 x 70) mm

* For more details see Figure 40.

NOTE	
	<p>Note that there must be external protection against output overload. This protection is possible by inserting a fuse externally, as for example, terminals 7, 8 and 9 in the case of the left hand figure. The others already have internal protection.</p>

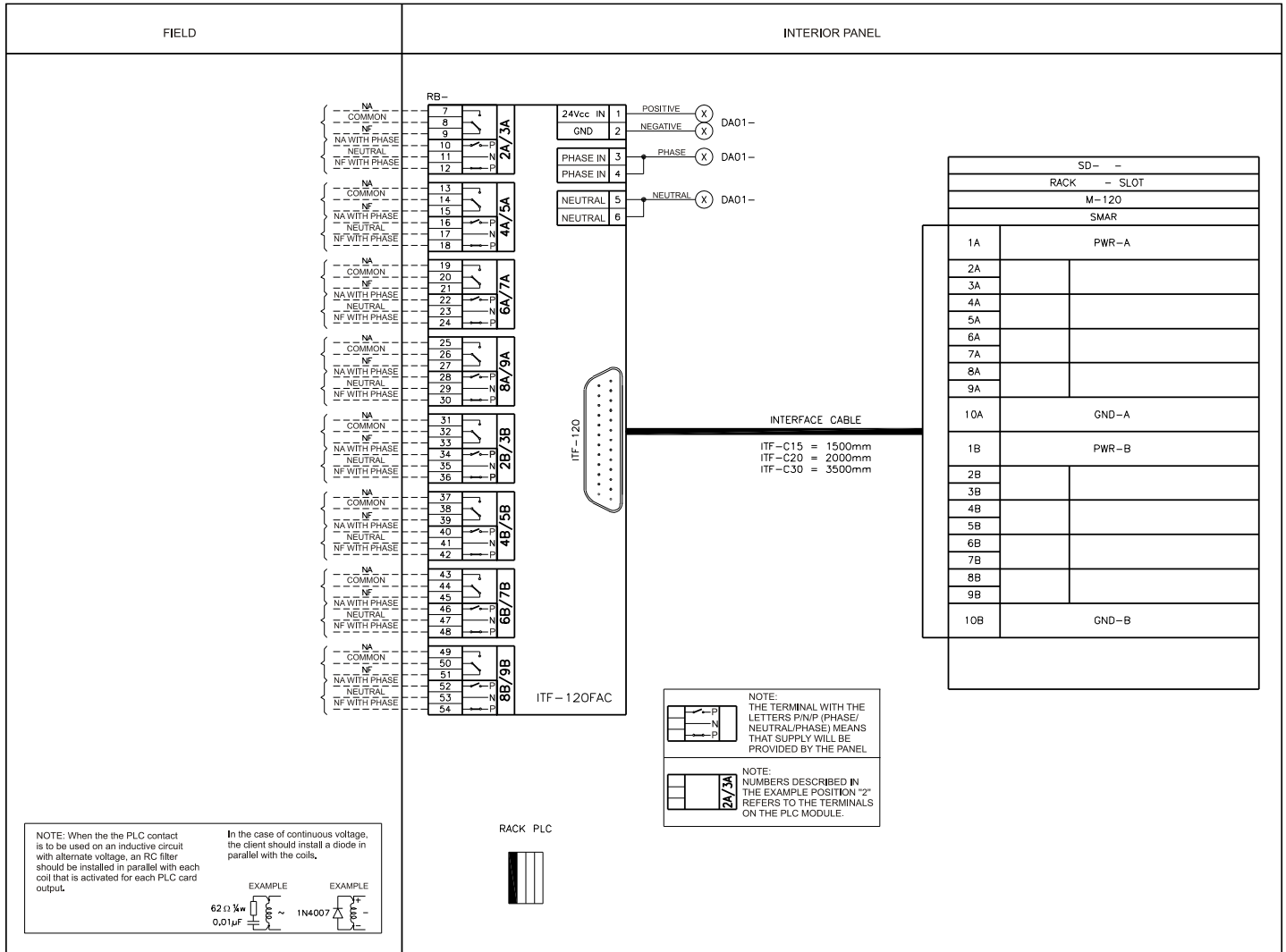

Figure 18 – ITF-120AC Interconnection Diagram

10-point Interface for Power Supply Distribution

Ordering Code

ITF - QDA-AC - Power supply distribution table for 10-point AC load 110/240 VAC @ 2A per point interface, 2 A per point.

ITF - QDA-DC - Power supply distribution table for 10-point DC load 24 Vdc @ 2A per point interface, 2 A per point.

Description

Interface for power supply distribution on panel.

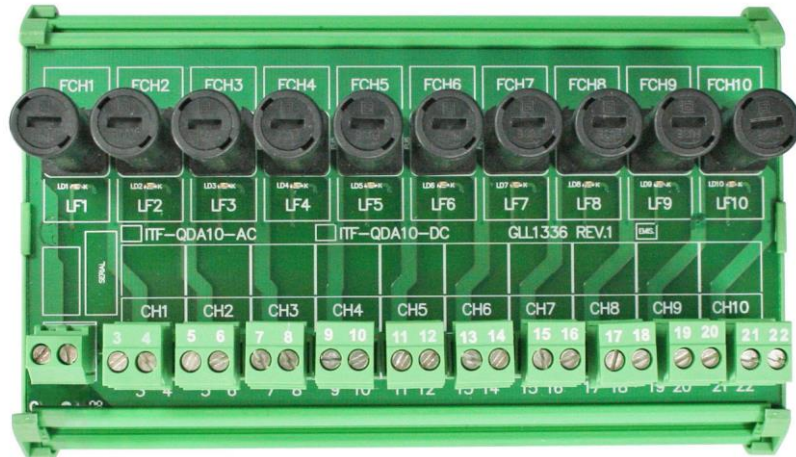

Figure 19 – ITF-QDA10-AC Interface Panel

Technical Specifications

ARCHITECTURE	
Output Number	10
Identification Plate	External Source and output tags

DC AUXILIARY SOURCE	
Maximum external source	ITF – QDA-AC: 264 Vac ITF - QDA-DC: 30 Vdc

OUTPUT	
Maximum Current per output	2 A
Terminals	2 terminals for each output
Protection	Fuse
Burning fuse Indication *	Red LED

*For burning fuse indication the load must be connected.

CONNECTION FOR FIELD	
2 terminals per output, up to 2 wires (1,5 mm ²) per terminal.	

MECHANICAL INFORMATION	
Mounting	DIN rail
Dimensions (L x W x H)*	(290 x 89.6 x 70) mm

* For more details see Figure 40.

Diode Matrix Interface

Ordering Code

ITF - D-12 - Diode Matrix Interface for 12 bulbs test

Description

Diode interface for lamp tests.

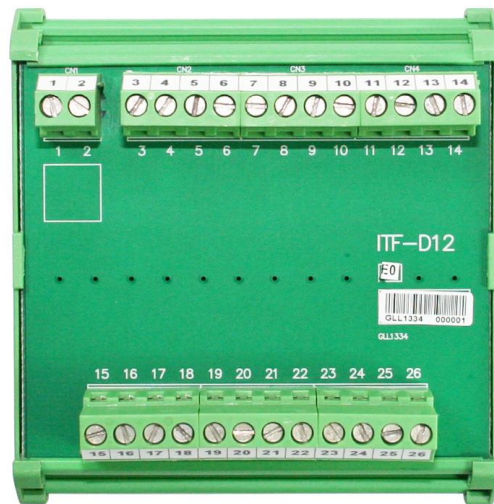

Figure 20 – ITF-D12 Interface Panel

Technical Specifications

ARCHITECTURE	
Channel Number	1 group with 12 diodes
CHANNEL	
Maximum external source	600 V
Maximum current per channel	800 mA
CONNECTION FOR FIELD	
2 terminals per output, up to 2 wires (1.5 mm ²) per terminal.	
MECHANICAL INFORMATION	
Mounting	DIN rail
Dimensions (L x W x H)*	(290 x 89.6 x 70) mm

* For more details see Figure 40.

Diode for Decoupling of Power Supply for Redundancy

Ordering Code

ITF-DR: Diode for Decoupling of Power Supply for Redundancy

Description

This interface can be used for decoupling of power supply, with the outputs in paralleled, with purpose of redundancy.

- Supports load up to 20A;
- Easy mounting in DIN rail.



Figure 21 – ITF-DR Interface Panel

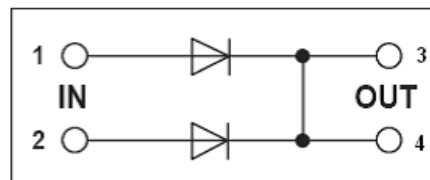

Figure 22 – Pinning the ITF-DR

Technical Specifications

FUNCTIONAL SPECIFICATIONS	
Input Voltage $U_n/U_{m\acute{a}x}$	24/30 Vdc
Maximum Input Current	1 x 20 A
*Using cable of 4mm ²	2 x 10 A
Transient Suppressor for Diode	Yes
Reverse Polarity Protection	Yes
Overcurrent Protection	No. Provision should be made at source or externally
Input/Output Voltage Drop	Approximately 0.5 V
Operation Temperature	0 °C to 60 °C
Storage Temperature	-20 °C to 80 °C

CONNECTION
4 terminals, maximum 4 mm ²

MECHANICAL INFORMATION	
Mounting	DIN rail
Dimensions (L x W x H)*	(81 x 45 x 132) mm

* For more details see Figure 40.

Installation

The installation of the interface should be made to facilitate the horizontal convection.

NOTE
To ensure good air convection, use a minimum spacing between interfaces ITF-DR: - 12 cm (4.724 in) vertically; - 3 cm (1.181 in) horizontally;

Mounting:

Attach the top rail and press to lock the module. See Figure 23(a).

Removing:

Loosen the lock using a screwdriver and then disconnect the rail. See Figure 23(b).

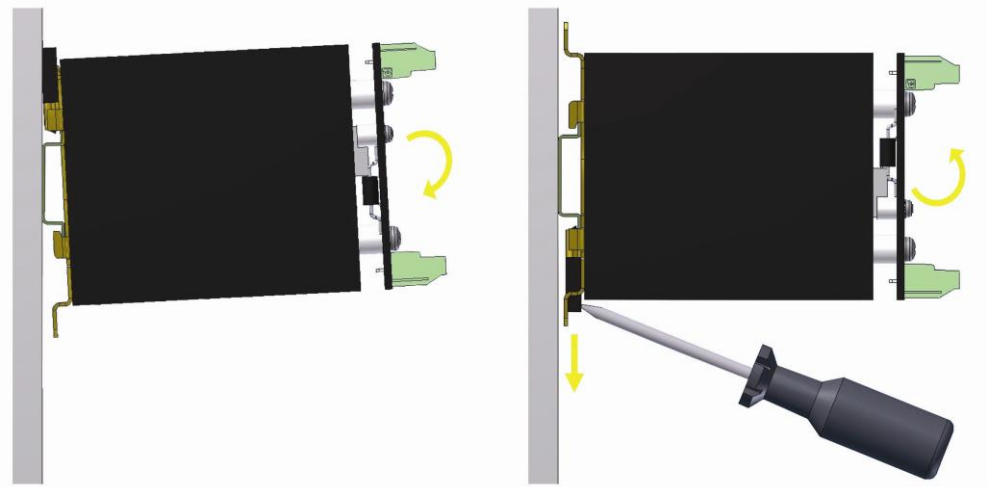

a) b)
Figure 23 – Assembly (a) and Disassembly (b) of the ITF-DR

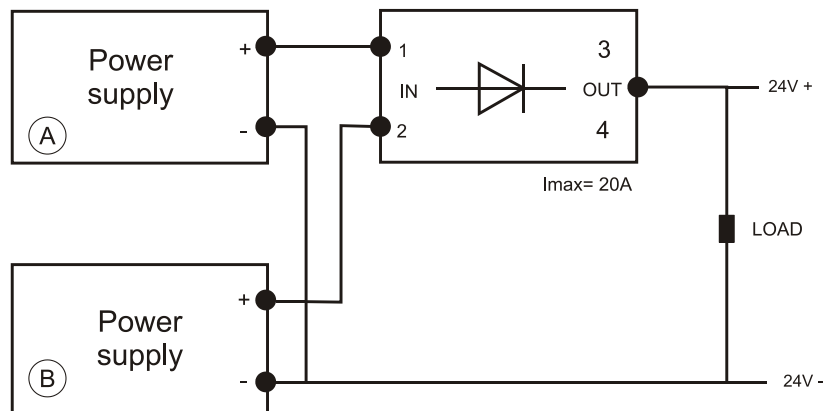

Figure 24 – ITF-DR Interconnection Diagram

Interface for 16-point Input/Output Digital 24 Vdc

Ordering Code

ITF-DIG - Interface for 16-point Input/Output Digital 24 Vdc, compatible only with DFI302 R-Series, modules DF111 and DF112.

Description

The interface for 16-point inputs/outputs digital DC is used together rack DF110-2, compatible only with DFI302 R-Series line, modules DF111 and DF112.



Figure 25 – ITF-DIG Interface for Panel

Technical Specifications

ARCHITECTURE	
Channel Number	16

DC AUXILIARY SOURCE	
External source (VEXT_A)	20 - 30 Vdc (output) 22 - 30 Vdc (input)
External source (VEXT_B)	20 - 30 Vdc (output) 22 - 30 Vdc (input)
Maximum consumption (VEXT_A)	850 mA @ 24 Vdc (output) 200 mA @ 24 Vdc (input)
Maximum consumption (VEXT_B)	850 mA @ 24 Vdc (output) 200 mA @ 24 Vdc (input)
External source indication	LED Green
Protection	Polarity

VOLTAGE PROTECTION PROVIDED TO SENSORS	
Fuse per point	100 mA
Burning fuse Indication *	Red LED

* For burning fuse indication the load must be connected.

INPUTS	
Input current per point	8 mA @ 24 Vdc

OUTPUTS	
Maximum output current per point	50 mA @ 24 Vdc

CONNECTION	
2 terminals supplying VEXT (positive and negative) and 1 for each input/output.	
Up to two wires (1.5 mm ²) per terminal.	

MECHANICAL INFORMATIONS	
Mounting	Trilho DIN
Dimensions (L x W x H)*	(290 x 89.6 x 70) mm

* For more details see Figure 40.

NOTE	
The power supply tension applied to the CN1 (VEXT-A) connector will power the redundant pair left I/O module, while the power supply tension applied to the CN2 (VEXT-B) will power the redundant pair right I/O module.	
For redundancy to be available on the level of the external power supply sources, the interface must be activated by two separate external power supply sources, one for the VEXT_A and the other for the VEXT_B.	
When to be used by only one external power supply source, activate both VEXT_A and VEXT_B connectors, so that both redundant pair modules will be powered.	

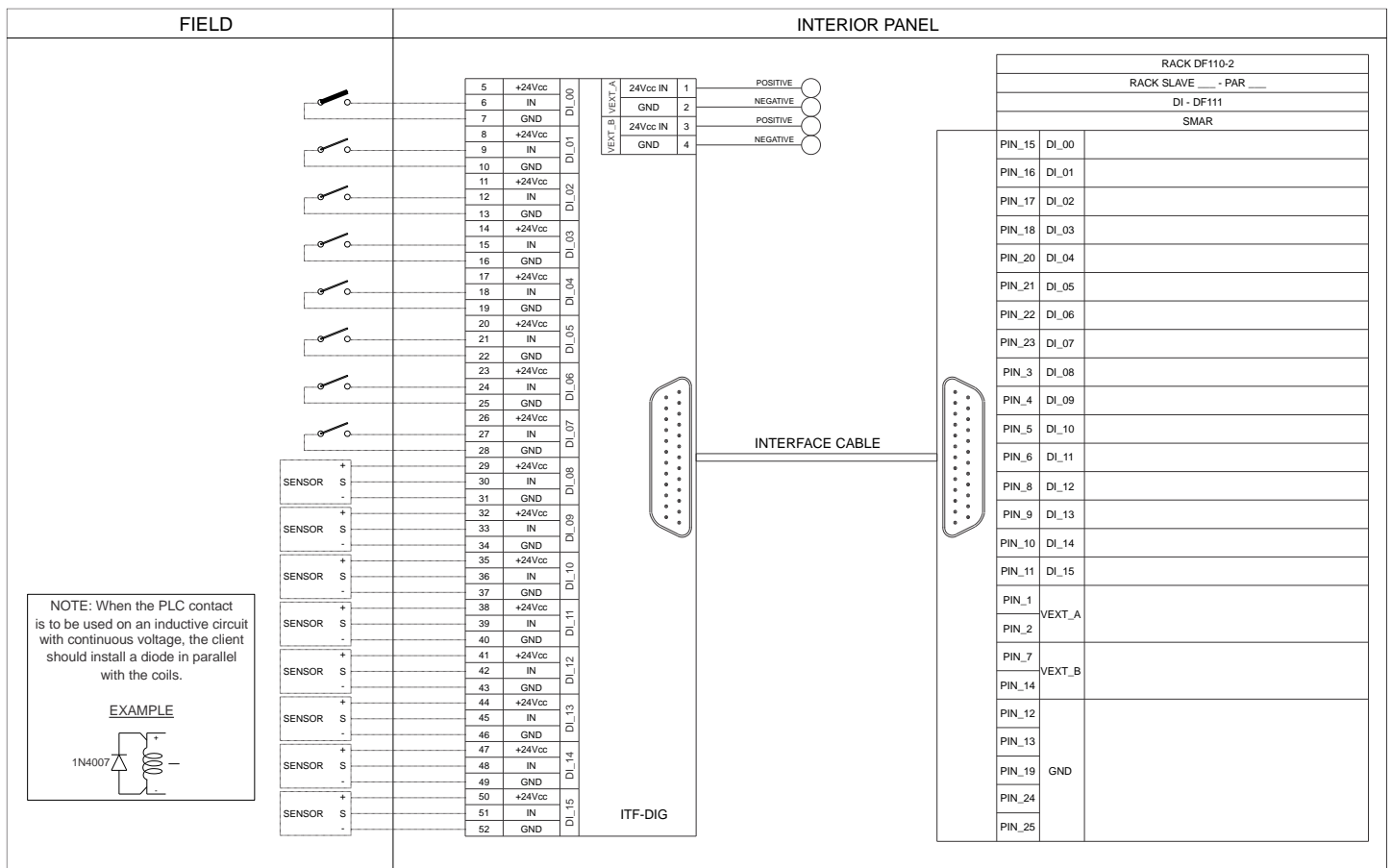

Figure 26 – ITF-DIG Interconnection Diagram with DF111 Module



Figura 27 – ITF-DIG Interconnection Diagram with DF112 Module

NOTE

Do not connect the cable shield to the device ground (clip it).

Interface for 8-points Analog Input/Output

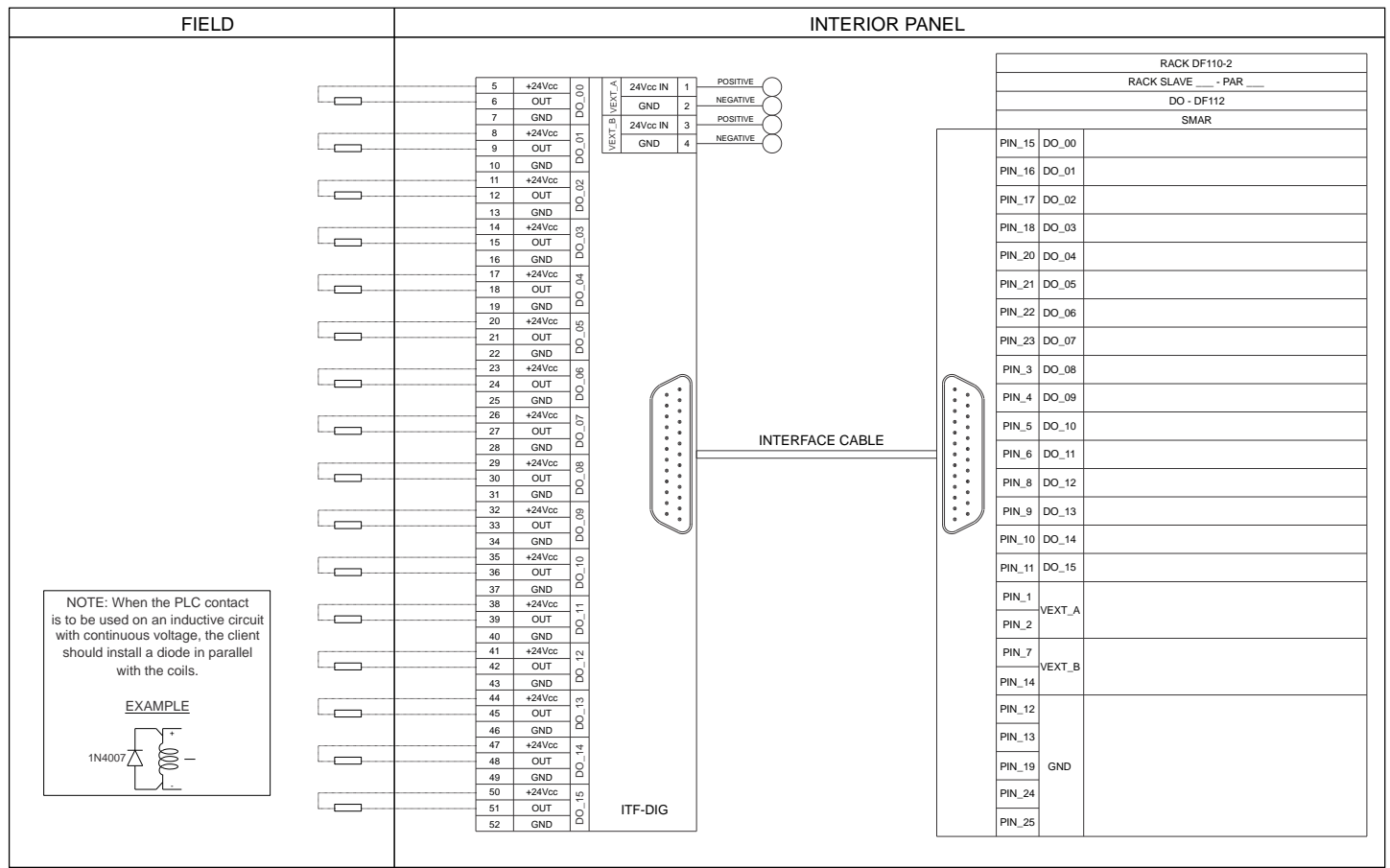
Ordering Code

ITF-AN-IOR - Interface for 8-point Analog Input/Output, compatible only with DFI302 R-Series, modules DF113 and DF114.

Description

The interface for 8-point analog input/output is used together rack DF110-2, compatible only with the DFI302 R-Series modules, DF113 and DF114.

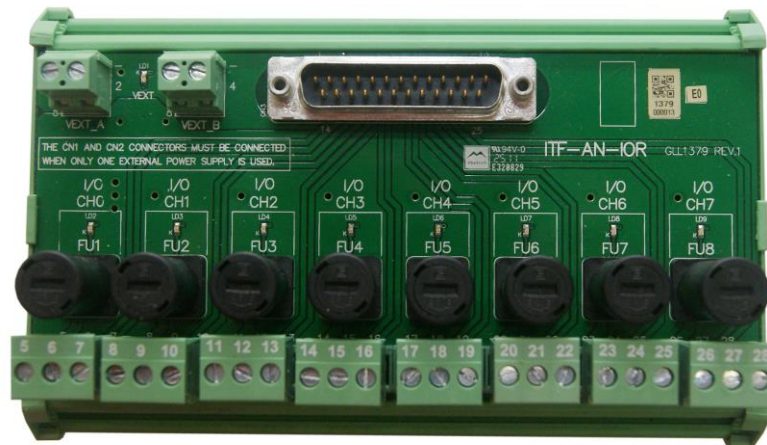

Figure 28 – ITF-AN-IOR Interface for Panel

Technical Specifications

ARCHITECTURE	
Channel Number	8

DC AUXILIARY SOURCE	
External source (VEXT_A)	20 - 30 Vdc (output) 22 - 30 Vdc (input)
External source (VEXT_B)	20 - 30 Vdc (output) 22 - 30 Vdc (input)
Maximum consumption (VEXT_A)	250 mA @ 24 Vdc (output) 250 mA @ 24 Vdc (input)
Maximum consumption (VEXT_B)	250 mA @ 24 Vdc (output) 250 mA @ 24 Vdc (input)
Indication	LED verde
Protection	Polaridade

INPUT/OUTPUT	
Maximum current per point	22 mA @ 24 Vdc

VOLTAGE PROTECTION PROVIDED TO SENSORS	
Fuse per point	100 mA
Burning fuse Indication *	Red LED

*For burning fuse indication the load must be connected.

CONNECTION	
2 terminals supplying VEXT (positive and negative) and 1 for each input/output.	
Up to two wires (1.5 mm ²) per terminal.	

MECHANICAL INFORMATIONS	
Mounting	DIN rail
Dimensions (L x W x H)*	(146 x 89.6 x 70) mm

* For more information see Figure 40.

NOTE
The power supply tension applied to the CN1 (VEXT-A) connector will power the redundant pair left I/O module, while the power supply tension applied to the CN2 (VEXT-B) will power the redundant pair right I/O module.
For redundancy to be available on the level of the external power supply sources, the interface must be activated by two separate external power supply sources, one for the VEXT_A and the other for the VEXT_B.
When to be used by only one external power supply source, activate both VEXT_A and VEXT_B connectors, so that both redundant pair modules will be powered.

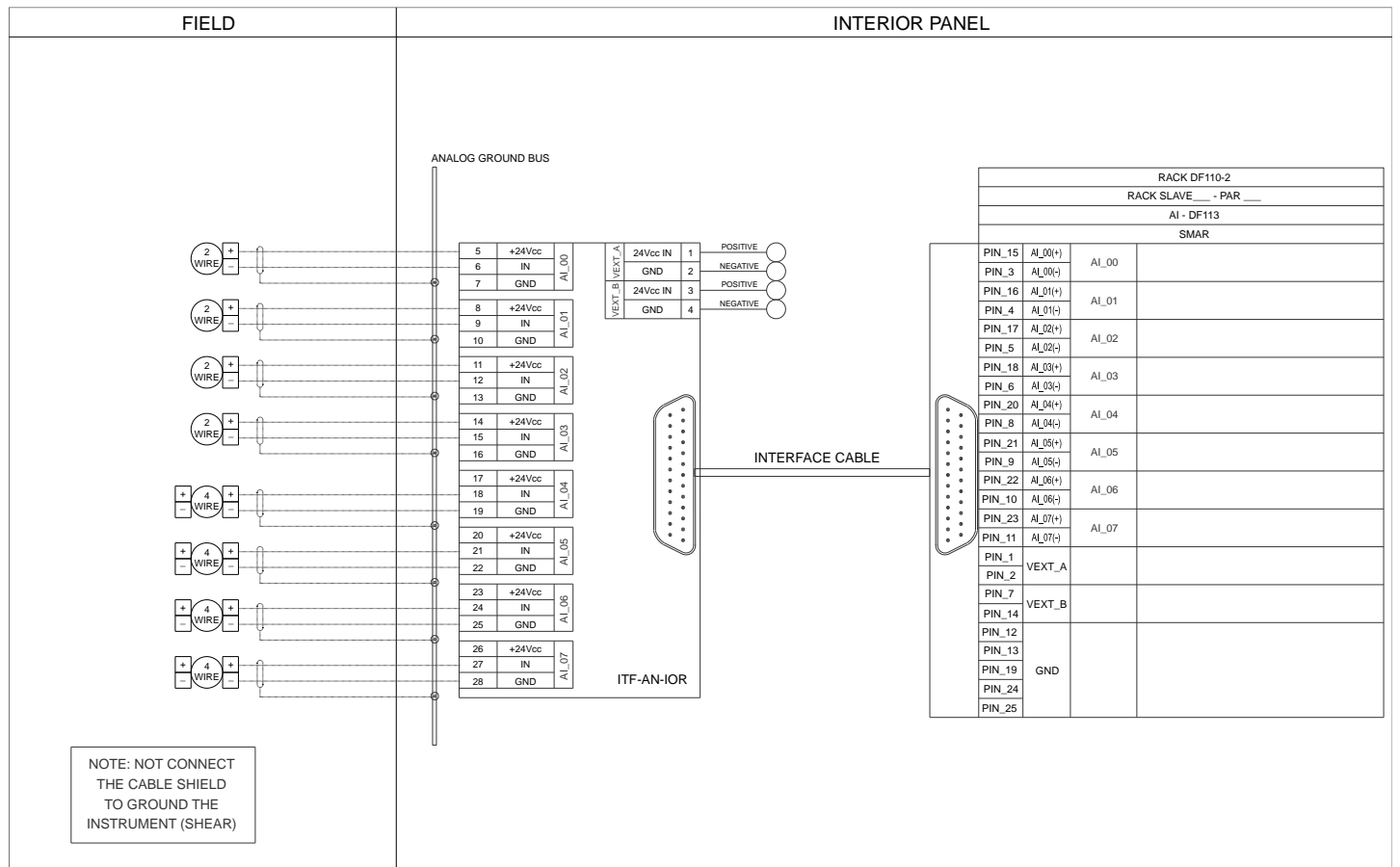

Figure 29 – ITF-AN-IOR Interconnection Diagram with DF113 Module

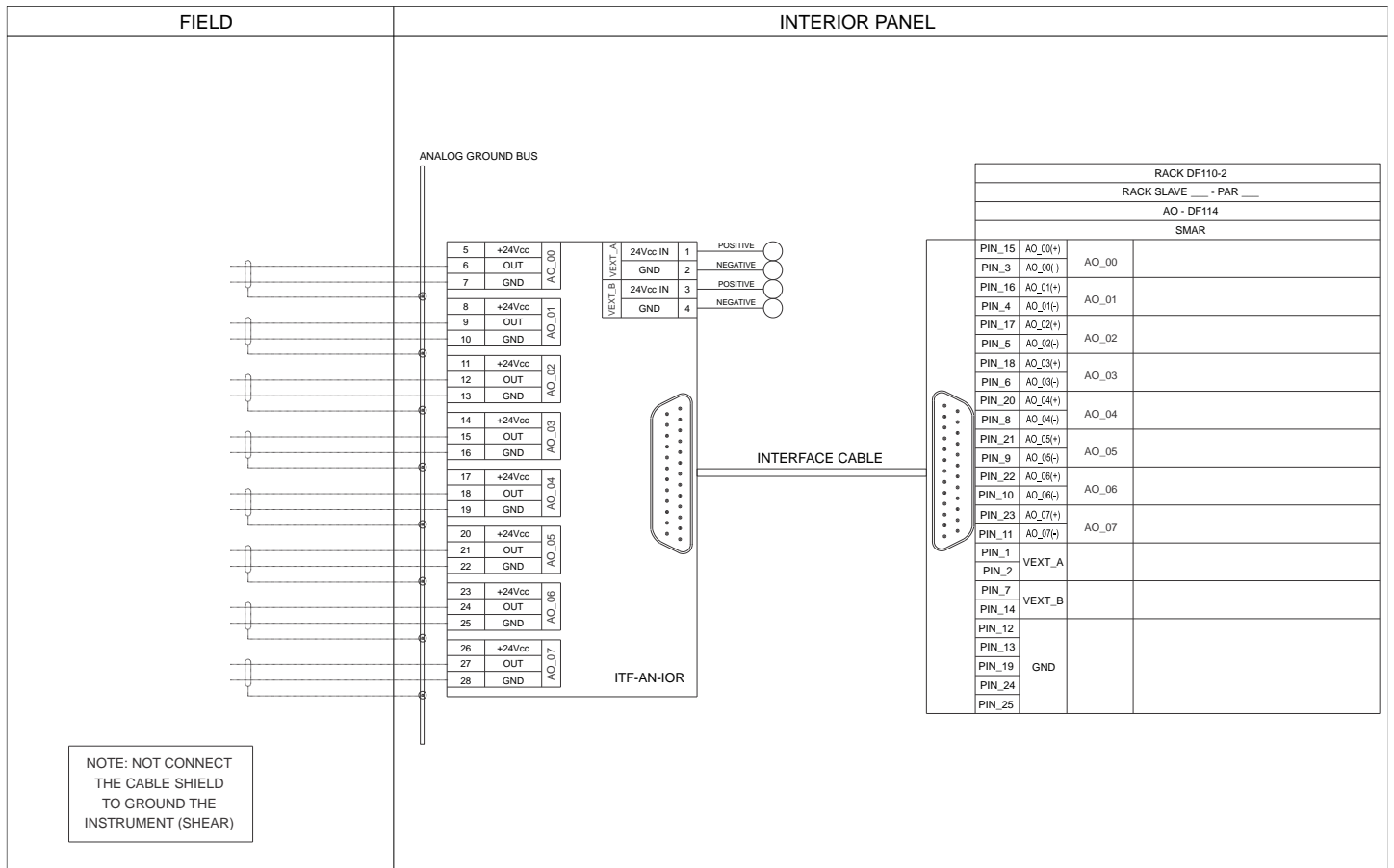

Figure 30 – ITF-AN-IOR Interconnection Diagram with DF114 Module

NOTA
Do not connect the cable shield to the device ground (clip it).

Interface for CD600plus

Ordering Code

ITF-CD-0: Interface for CD600plus, digital outputs without fuse;
 ITF-CD-A: Interface for CD600plus, digital outputs with fuse, for AC load;
 ITF-CD-D: Interface for CD600plus, digital outputs with fuse, for DC load.



Figure 31 – ITF-CD-0 Interface for Panel (Digital outputs without fuse)

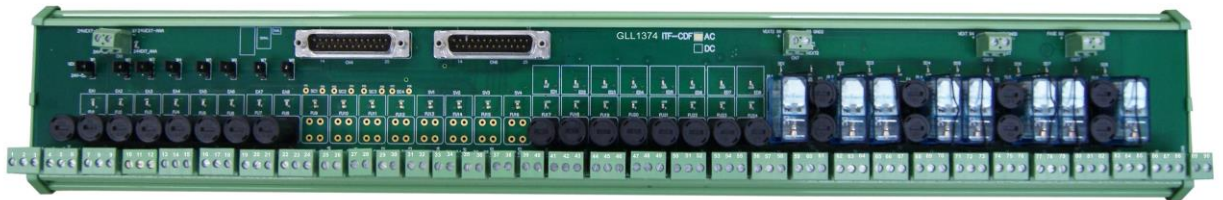

Figure 32 – ITF-CD-A Interface for Panel (Digital outputs with fuse)

Technical Specifications for Analog Input 8-Point Interface

This interface has 8 inputs that are compatible with the controller 8 analog inputs.

VOLTAGE PROVIDE FOR SENSORS	
Voltage selection for sensors, external power supply or controller power supply	Using jumpers
Individual protection by input	Fuse 100 mA
Burning fuse Indication*	Red LED

*For burning fuse indication the load must be connected.

DC AUXILIARY SOURCE	
Power Supply	22 - 30 Vdc
Maximum Current	200 mA @ 24 Vdc
Indication	Green LED
Protection	Polarity

INPUTS	
Maximum per-point current input	22 mA @ 24 Vdc

CONNECTION	
3 terminals: auxiliary 24 Vdc input and ground.	
Up to two wires (1.5 mm ²) per terminal.	

Technical Specifications for Analog Output 8-Point Interface

This interface has 8 outputs that are compatible with the controller analog outputs.

ARCHITECTURE	
Output Number	8

SAÍDAS	
Terminals	Two terminals for each output
Diode to measure the output current	Yes, on the output currents

CONNECTION	
2 terminals: analog output and ground	
Up to two wires (1.5 mm ²) per terminal.	

Technical Specifications for Digital 8-Input Interface

This interface has 8 inputs that are compatible with the controller digital inputs.

ARCHITECTURE	
Output Number	8

DC AUXILIARY SOURCE	
Power Supply	22 - 30 Vdc
Maximum Current	200 mA @ 24 Vdc
Indication	Green LED
Protection	Polarity

VOLTAGE PROTECTION PROVIDE FOR SENSORS	
Fuse for input	100 mA
Burning Fuse Indication *	Red LED

*For burning fuse indication the load must be connected.

INPUTS	
Input current per point	2 mA @ 24 Vdc
Status LED	Yellow LED

CONNECTION	
3 terminals: 2 terminals supplying power to the positive and negative sensors and 1 for input.	
Up to two wires (1.5 mm ²) per terminal.	

Technical Specifications for 24 Vdc Digital Output 8-Point Interface Compatible with NA and NF Contact Relay without Fuse for the ITF-CD-0

Digital output 8-points interface to relay with NA and NF contacts, compatible with the controller digital outputs.

ARCHITECTURE	
Output number	8

DC AUXILIARY SOURCE	
Power Supply	20 - 30 Vdc
Maximum Current	225 mA @ 24 V
Indication	Green LED
Protection	Polarity

OUTPUTS	
1 NA contact, 1 NF contact, 3 terminal / output	1 NA contact, 1 NF contact
Vac range	20 – 250 Vac
Vdc range	20 – 110 Vdc
Maximum current for 250 Vac	2 A (resistive); 2 A (inductive)
Maximum current for 30 Vdc	2 A (resistive); 2 A (inductive)
Leakage current	None M-127: 500 μ A @ 100 Vac
Overload protection per output	Must be provided externally
Burning Fuse Indication	Red LED
Operation time	10 ms (maximum)
Mechanical life – switching cycles	20.000.000 operations (min.) @ current (max).
Status indication	Yellow LED
Relay sockets	Yes

CONNECTION
3 terminals: common, NA contact and NF contact.
Up to two wires (1.5 mm ²) per terminal.

Technical Specifications for 24 Vdc Digital Output 8-Point Interface Compatible with NA and NF Contact Relay with Fuse for the ITF-CD-A/C

Digital output 8-points interface for NA and NF contact relay, compatible with the controller digital outputs.

ARCHITECTURE	
Output number	8

DC AUXILIARY SOURCE	
Power Supply	20 - 30 Vdc
Maximum Current	280 mA @ 24 Vdc
Indication	Green LED
Protection	Polarity

OUTPUT	
1 NA contact, 1 NF contact, 3 terminal / output	1 NA contact, 1 NF contact
Vac range	20 – 250 Vac
Vdc range	20 – 110 Vdc
Maximum current for 250 Vac	2 A (resistive); 2 A (inductive)
Maximum current for 30 Vdc	2 A (resistive); 2 A (inductive)
Leakage current	None M-127: 500 μ A @ 100 Vac
Overload protection per output	Fuse (2A)
Burning Fuse Indication*	Red LED
Operation time	10 ms (maximum)
Mechanical life – switching cycles	20.000.000 operations (min.) @ current (max).
Status indication	Yellow LED
Relay sockets	Yes

*For burning fuse indication the load must be connected.

CONNECTION
3 terminals: NF contact phase , NA contact phase and neutral.
Up to two wires (1.5 mm ²) per terminal.

MECHANICAL INFORMATION	
Mounting	DIN rail
Dimensions (L x W x H)*	(542.7 x 89.6 x 75.6) mm

* For more details see Figure 40.

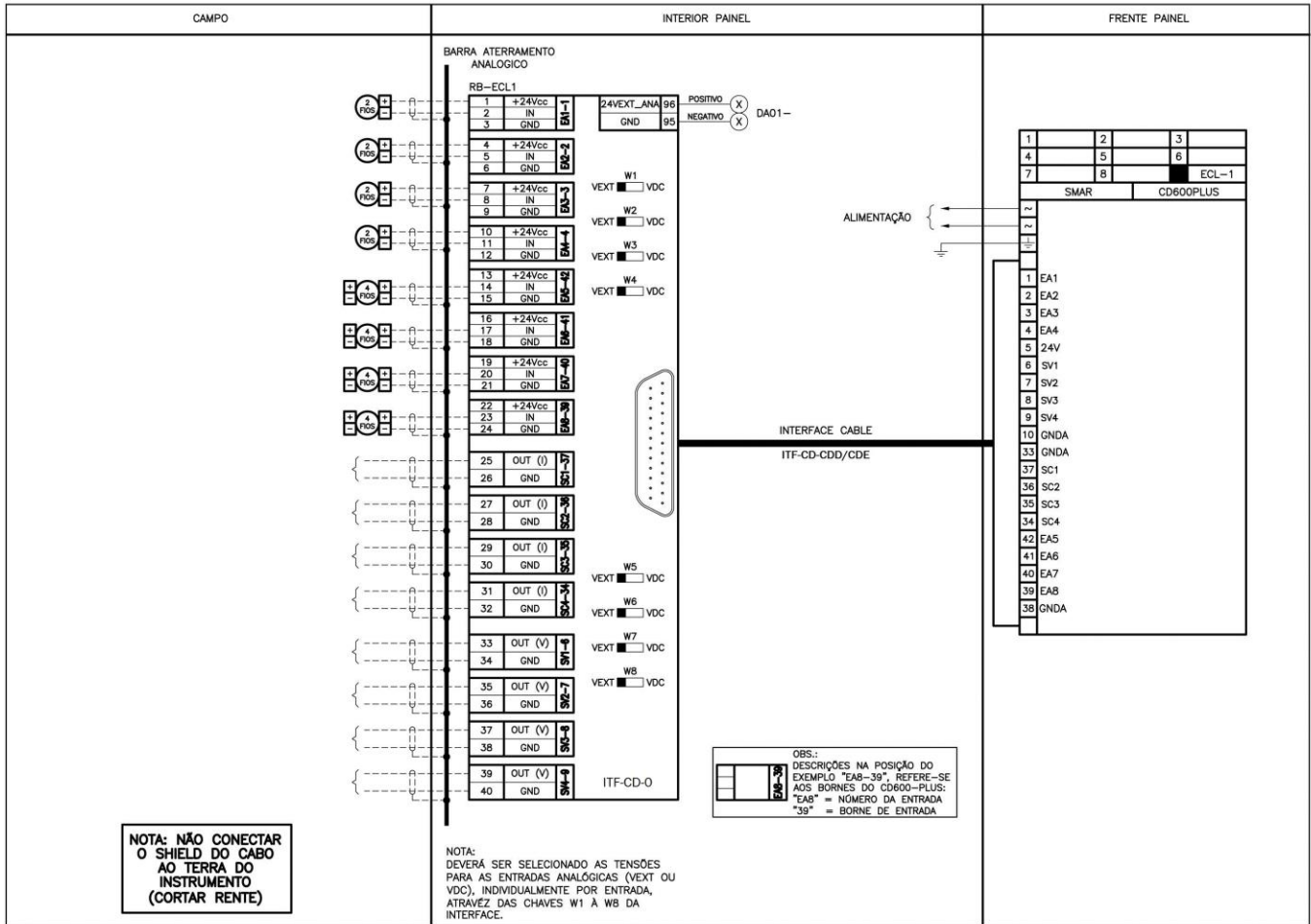

Figure 33 –ITF-CD-0 Analog Interconnection Diagram

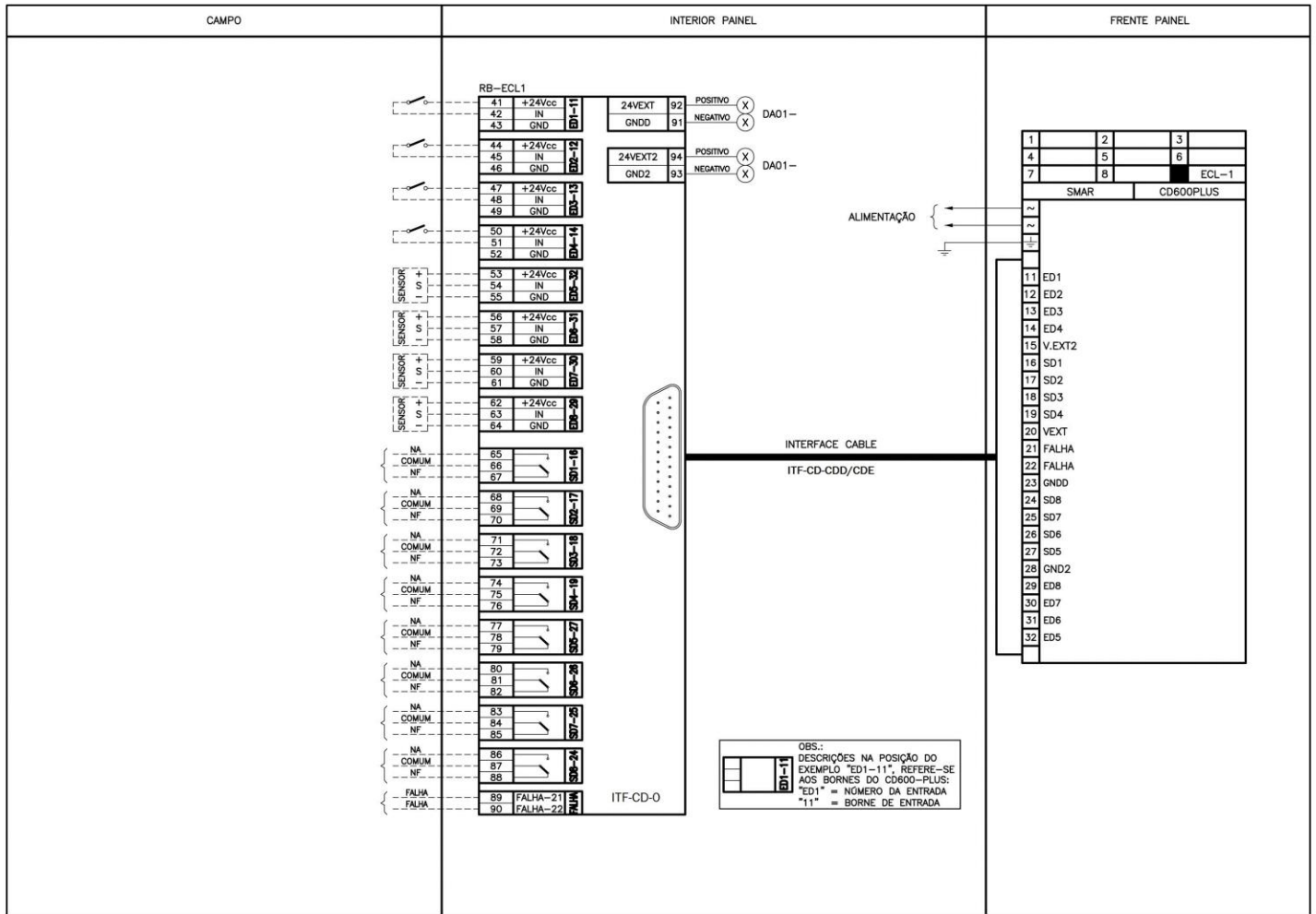

Figure 34 – ITF-CD-0 Digital Interconnection Diagram

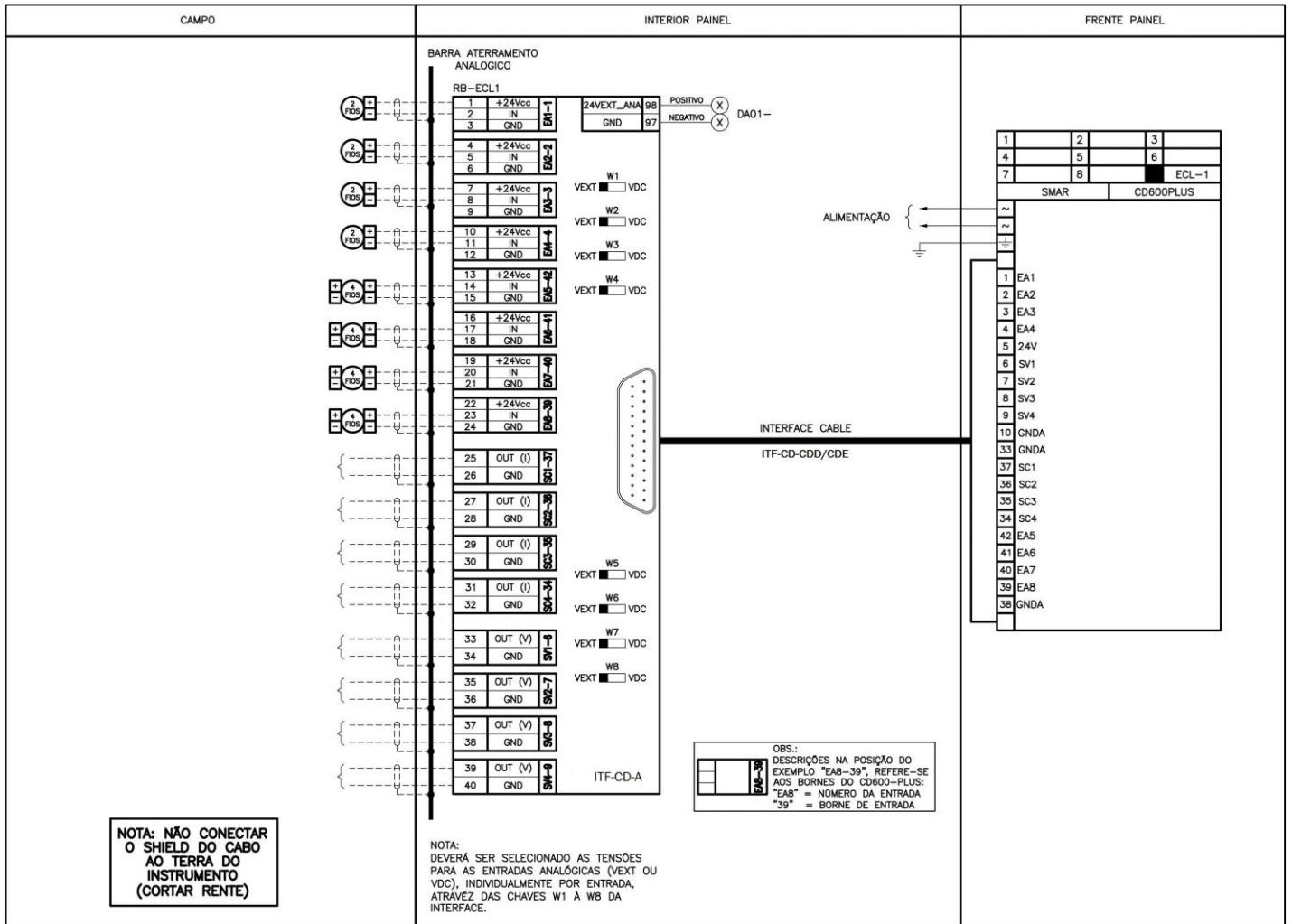

Figure 35 –ITF-CD-A Analog Interconnection Diagram

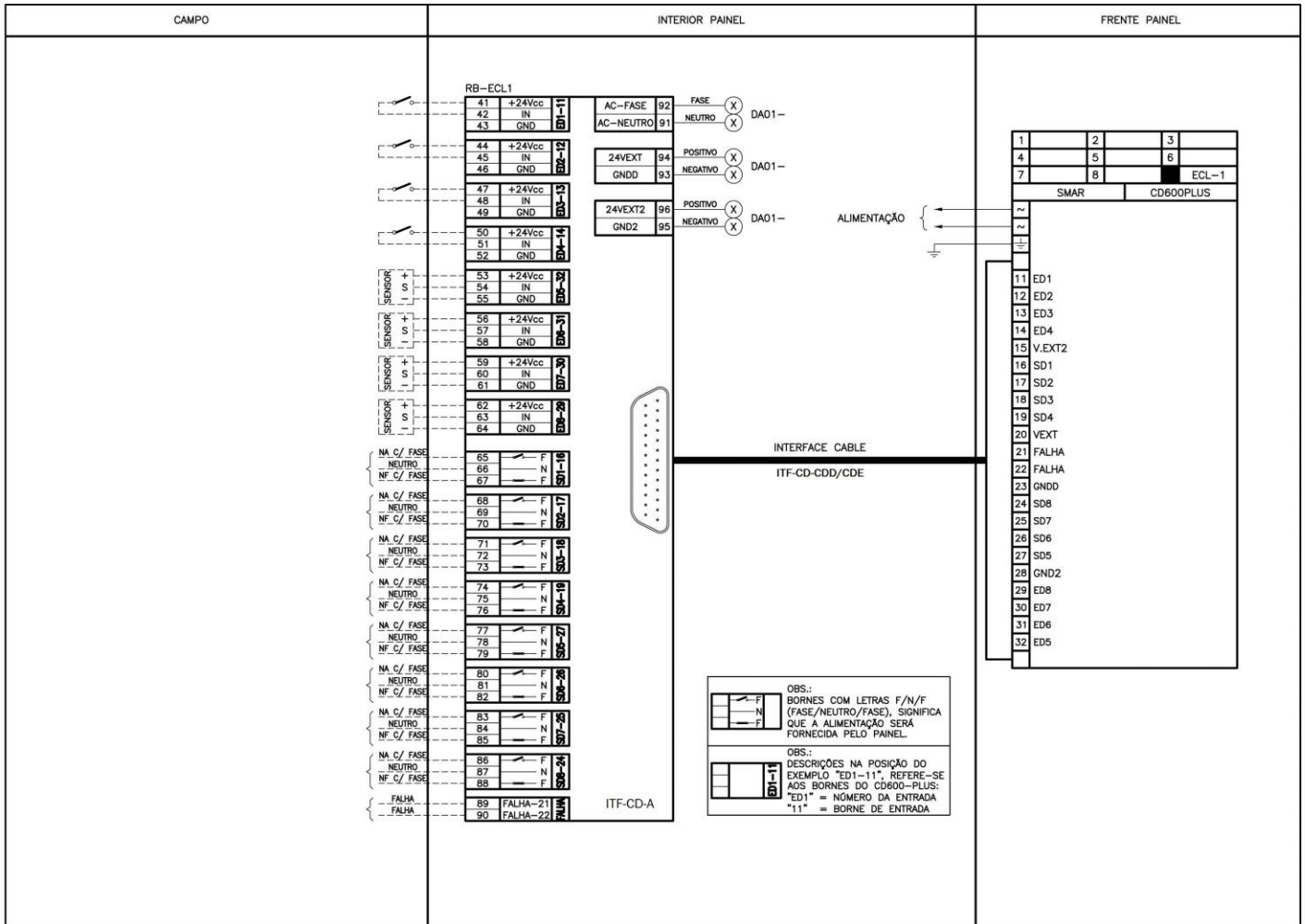

Figure 36 –ITF-CD-A Digital Interconnection Diagram

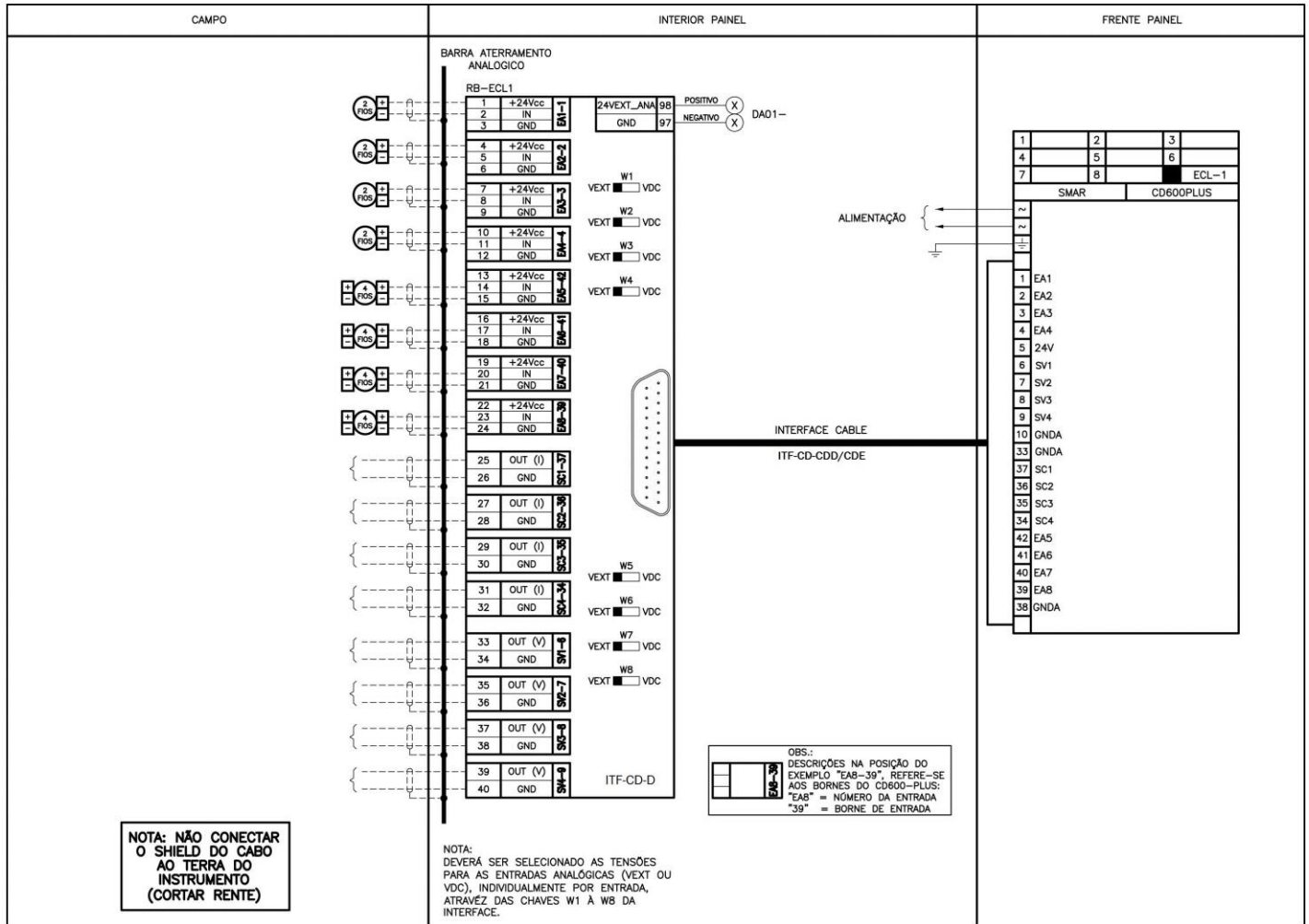

Figure 37 –ITF-CD-D Analog Interconnection Diagram

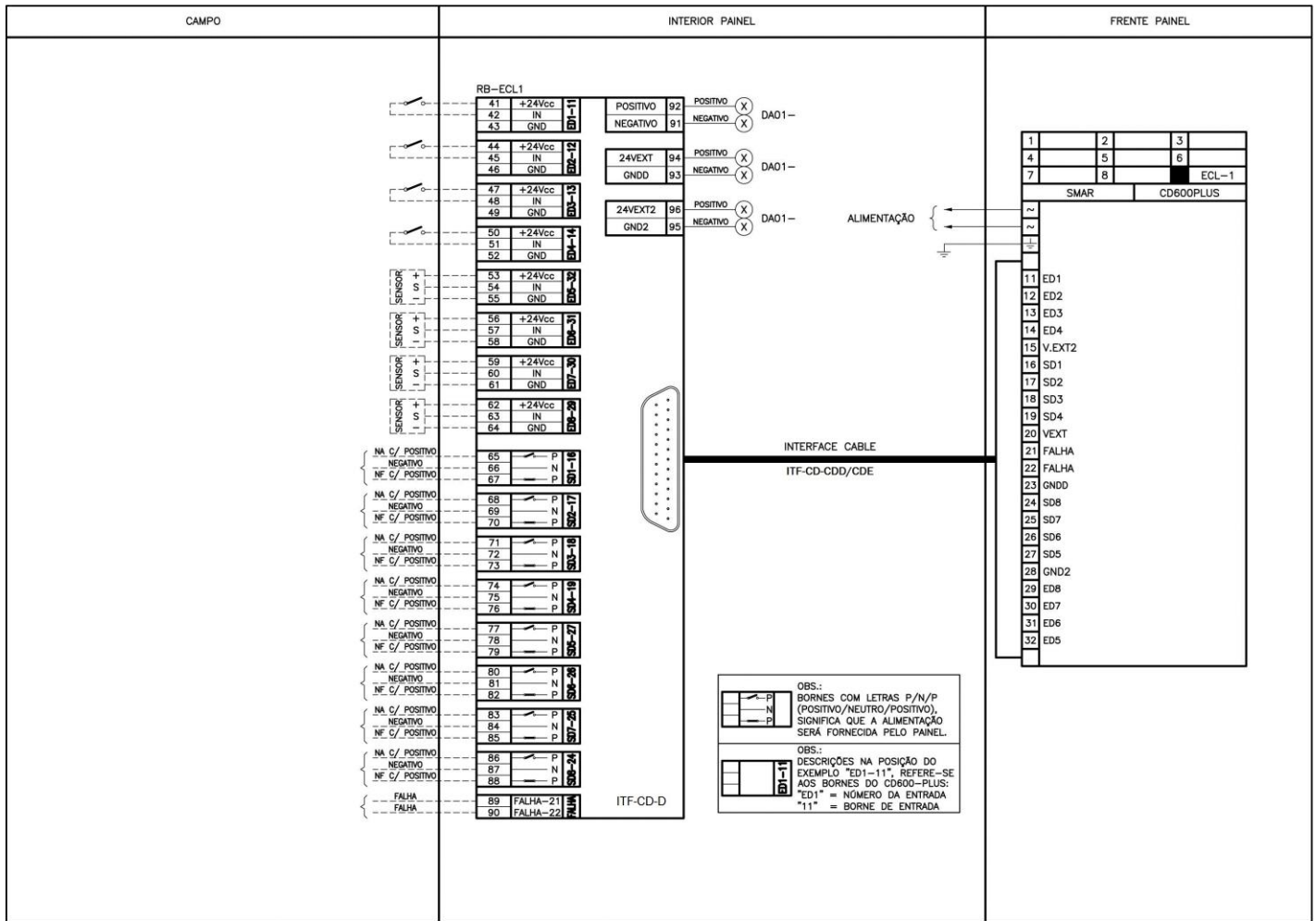

Figure 38 – ITF-CD-D Digital Interconnection Diagram

Spart Part Components

LIST OF SPARE PARTS	
COMPONENTS DESCRIPTION	CODE
Relay with 1 pole (package with 10 pieces); ITF-101/ITF-102/ITF-123-7	400-1123
Relay with 2 poles (package with 10 pieces); ITF-120	400-1124
Fuse 5 x 20 mm – 2A (package with 10 pieces); ITF	400-1125
Fuse 5 x 20 mm – 100 mA (package with 10 pieces); ITF	400-1126
Terminal block with 3 terminals (package with 10 pieces); ITF	400-1127
Terminal block with 2 terminals (package with 10 pieces); ITF	400-1128
Fuse carrier (package with 5 pieces); ITF	400-1129

Connection Cables

Ordering Code

ITF - C-10 - Connection cable between LC700/DFI302 modules and ITF interfaces - 1.0 m length
ITF - C-15 - Connection cable between LC700/DFI302 modules and ITF interfaces - 1.5 m length
ITF - C-20 - Connection cable between LC700/DFI302 modules and ITF interfaces - 2.0 m length
ITF - C-25 - Connection cable between LC700/DFI302 modules and ITF interfaces - 2.5 m length
ITF - C-30 - Connection cable between LC700/DFI302 modules and ITF interfaces - 3.0 m length
ITF - C-35 - Connection cable between LC700/DFI302 modules and ITF interfaces - 3.5 m length
ITF - C-40 - Connection cable between LC700/DFI302 modules and ITF interfaces - 4.0 m length
ITF - C-45 - Connection cable between LC700/DFI302 modules and ITF interfaces - 4.5 m length
ITF - C-50 - Connection cable between LC700/DFI302 modules and ITF interfaces - 5.0 m length
ITF - CDE-0 - Connection cable between CD6000plus (left) and interfaces ITF – 0.5 m length
ITF - CDE-1 - Connection cable between CD6000plus (left) and interfaces ITF – 1.0 m length
ITF - CDE-2 - Connection cable between CD6000plus (left) and interfaces ITF – 1.5 m length
ITF - CDE-3 - Connection cable between CD6000plus (left) and interfaces ITF – 2.0 m length
ITF - CDE-4 - Connection cable between CD6000plus (left) and interfaces ITF – 2.5 m length
ITF - CDE-5 - Connection cable between CD6000plus (left) and interfaces ITF – 3.0 m length
ITF - CDE-6 - Connection cable between CD6000plus (left) and interfaces ITF – 3.5 m length
ITF - CDE-7 - Connection cable between CD6000plus (left) and interfaces ITF – 4.0 m length
ITF - CDE-8 - Connection cable between CD6000plus (left) and interfaces ITF – 4.5 m length
ITF - CDE-9 - Connection cable between CD6000plus (left) and interfaces ITF – 5.0 m length
ITF - CDD-0 - Connection cable between CD6000plus (right) and interfaces ITF – 0.5 m length
ITF - CDD-1 - Connection cable between CD6000plus (right) and interfaces ITF – 1.0 m length
ITF - CDD-2 - Connection cable between CD6000plus (right) and interfaces ITF – 1.5 m length
ITF - CDD-3 - Connection cable between CD6000plus (right) and interfaces ITF – 2.0 m length
ITF - CDD-4 - Connection cable between CD6000plus (right) and interfaces ITF – 2.5 m length
ITF - CDD-5 - Connection cable between CD6000plus (right) and interfaces ITF – 3.0 m length
ITF - CDD-6 - Connection cable between CD6000plus (right) and interfaces ITF – 3.5 m length
ITF - CDD-7 - Connection cable between CD6000plus (right) and interfaces ITF – 4.0 m length
ITF - CDD-8 - Connection cable between CD6000plus (right) and interfaces ITF – 4.5 m length
ITF - CDD-9 - Connection cable between CD6000plus (right) and interfaces ITF – 5.0 m length
ITF - CR-10 - Connection cable between DFI302 R-Series modules and Interfaces ITF – 1.0 m length
ITF - CR-15 - Connection cable between DFI302 R-Series modules and Interfaces ITF – 1.5 m length
ITF - CR-20 - Connection cable between DFI302 R-Series modules and Interfaces ITF – 2.0 m length
ITF - CR-25 - Connection cable between DFI302 R-Series modules and Interfaces ITF – 2.5 m length
ITF - CR-30 - Connection cable between DFI302 R-Series modules and Interfaces ITF – 3.0 m length
ITF - CR-35 - Connection cable between DFI302 R-Series modules and Interfaces ITF – 3.5 m length
ITF - CR-40 - Connection cable between DFI302 R-Series modules and Interfaces ITF – 4.0 m length
ITF - CR-45 - Connection cable between DFI302 R-Series modules and Interfaces ITF – 4.5 m length
ITF - CR-50 - Connection cable between DFI302 R-Series modules and Interfaces ITF – 5.0 m length

Description

Cables for interconnecting the interfaces to the Smar I/O modules.

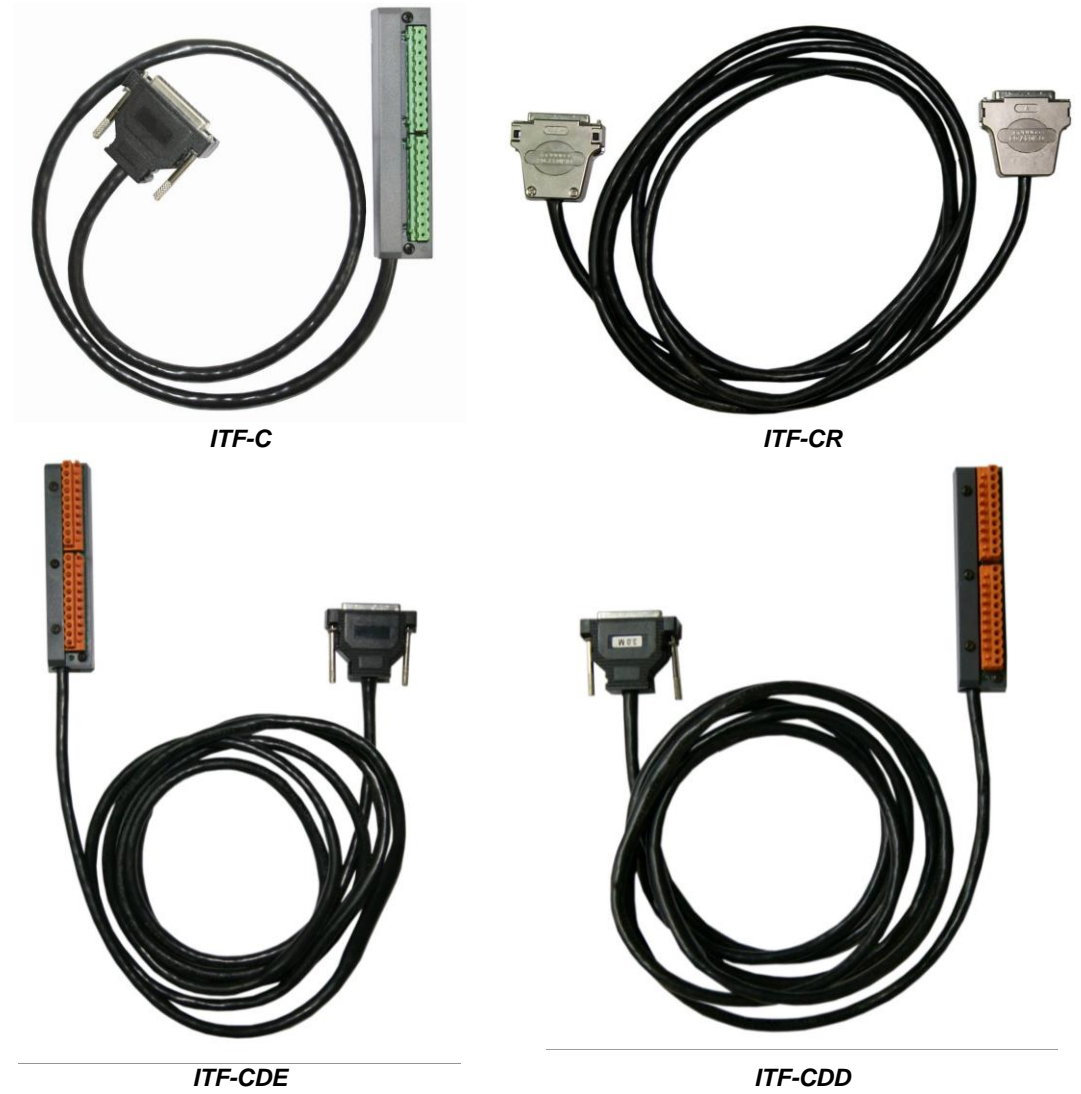

Figure 39 – Connection Cable for Interfaces

Technical Specifications

CHANNELS	
Isolation	300 V
Conductors Gauge	28 AWG
Maximum Current per Channel	500 mA

Basic Rules for Panel Mounting

Installation Condition

Ambient: 0 to 60 °C, 20 to 90% RH non-condensing.

Dimensions

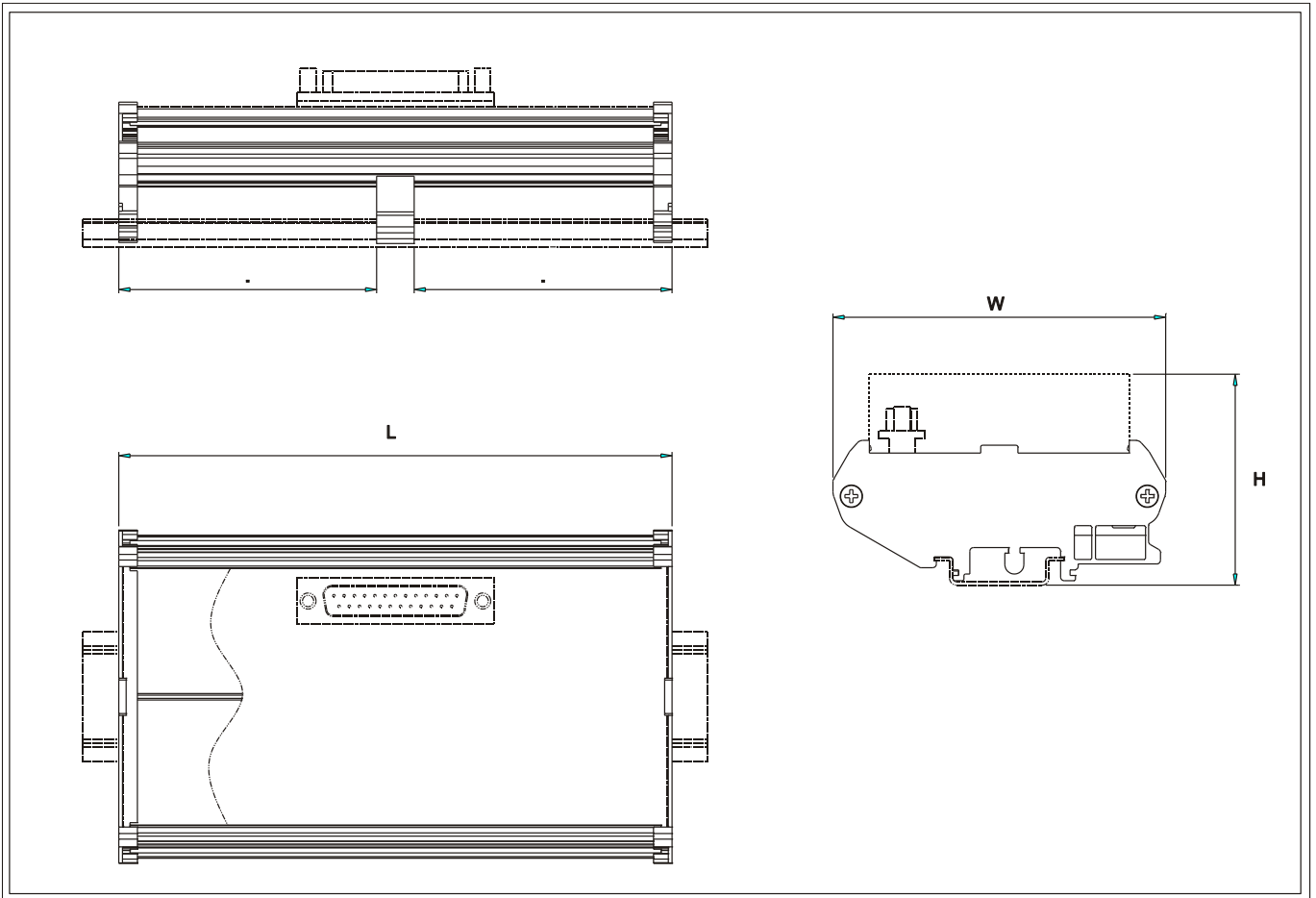

Figure 40 – Dimensional Drawings

