

# HCC301

# smar

DEC / 08  
HCC301

## INSTALLATION GUIDE

### Hart to Current Converter

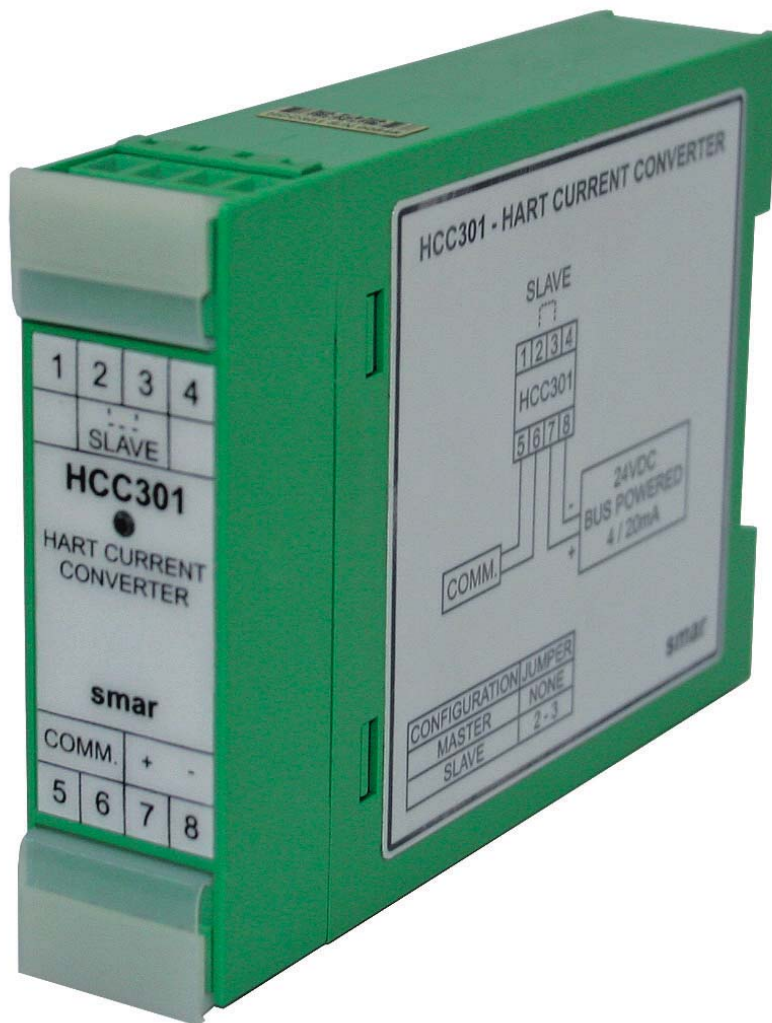

HCC301ME

smar  
www.smar.com

Specifications and information are subject to change without notice.  
Up-to-date address information is available on our website.

web: [www.smar.com/contactus.asp](http://www.smar.com/contactus.asp)

## 1 - Introduction

The HCC301 is a HART to Current Converter and it converts a digital variable from the HART communication in an analog current signal, allowing that this variable is monitored and controlled. It is an interface that helps the communication between the field and the control room.

## 2 - Functionality

The HCC301 supports master or slave behavior. To choose one of the options, use the configuration jumper.

### 2.1 - Configuration Jumper

Master - No jumper  
Slave - Using jumper

### 2.2 - Master

When the HCC301 is set as master, it is responsible to convert the digital variable obtained through HART communication in an analog current signal. Available variables are presented below:

- PV% (First Variable) - Accessible through the command #2 of the “**Universal Command**” from the HART protocol.
- PV (First Variable) – Accessible through the command #1 of the “**Universal Command**” from the HART protocol.
- SV (Second Variable) - Accessible through the command #3 of the “**Universal Command**” from the HART protocol.
- TV (Third Variable) - Accessible through the command #3, of the “**Universal Command**” from the HART protocol.
- QV (Fourth Variable) - Accessible through the command #3, of the “**Universal Command**” from the HART protocol.
- Others - Accessible through the command #33, “**Common Practice**” of the HART protocol.

For the PV, SV, TV, QV variables and Others it is necessary to set the variable working range, i.e., the lower value (0% of the range) related to the 4 mA and the upper value (100% of the range) related to the 20 mA.

For the option “Others”, it is necessary to configure the variable index that should be read. To each device there are many different indexes according to the #33 command. Each index relates to a device variable.

The HCC301 sends the command and the slave device responds to the command relative to the desired variable that will be later converted in an analog current signal. The HCC301 may work with only one of these variables per time.

The next table shows the index list for the #33 command of a few devices.

Variables Command List #33 for the LD301 Device	
Index	Variable
0	Output in mA
1	Output in Percentage
2	Pressure (First variable)
3	Process variable in percentage – PV%
4	Process variable – PV
5	Temperature (Second variable)

Variables Command List #33 for the TT301 Device	
Index	Variable
0	Output in mA
1	Output in Percentage
2	Temperature – PV
3	Ambient temperature
4	Process variable in percentage – PV%

Variables Command List #33 for the FY301 Device		Variables Command List #33 for the FY400 Device	
Index	Variable	Index	Variable
0	Current input in mA	0	SetPoint in percentage
1	Process variable in percentage	1	Current input in milliampere
2	Setpoint current in percentage	2	SetPoint current in percentage
6	Setpoint in percentage	3	Process variable in percentage
9	Temperature in °C	9	Temperature in °C
11	Temperature in °F	10	Temperature in °F

Variables Command List #33 for the DT301 Device	
Index	Variable
0	Current output in mA
1	Concentration variable in percentage
2	Pressure in mmh20
3	Used concentration unit in %%
4	Used concentration unit
5	Temperature in °C
6	Temperature in °C or °F

Several devices may be connected through a multidrop configuration. The HCC301 is the primary master of this bus. It is also possible to connect a secondary master in this bus or a device working in the Burst mode. The HCC301 communicates with one device (slave) of the line and to accomplish this communication, it is necessary to previously put it in the slave mode. In this state, to set its address and the address of the device participating in the communication.

There are some conditions in which the current will go to FailSafe, they are shown below:  
 If there is loss of communication for a pre determinate time, then the current will assume the values of 3.6/21 mA;  
 Response Code with the status “Field device Malfunction” or “Busy” or “Command not implement”, the current will assume the values 3.6/21 mA;  
 Invalid check Sum, the current will be 3.6/21 mA;  
 Response Code with the status “PV out of limits” or “non PV out of limits”, the current will go to 3.8/20.5 mA. (This condition is possible only if the parameter status checking is enabled)

### 2.3 - Slave

When the HCC301 works as slave, it assumes the default address 1. The following configurations are possible in this condition. These configurations show how the HCC301 works when it is not in the master mode: Information, Configuration, Calibration and Maintenance.

### 3 - Info (Information)

**Tag** - 8 alphanumeric characters field to identify the HCC301.

**Service** - 16 alphanumeric characters field to additional identification of the HCC301.

**Modification Date** - The data used to identify a relevant date.

**Message** - 32 alphanumeric characters field to any other extra information.

### 4 - Conf (Configuration)

**Range** - This option allows to change the working range of the HCC301 when it is working as a master. The bottom value is equal to 0 % of the range and the upper value is equal to 100% of the range. The unit is according to the working variable.

**Safety** - The output current may be configured to go to the lower value of 3.6 mA or to the upper value of 21 mA, in case there is a communication failure, or any bad state.

**Variable** - This option sets the variable that the HCC301 will monitor when it is working as a master. Available variables are:

“PV%”, “PV”, “SV”, “TV”, “QV” and “Others”- For all these variables with the exception of “%PV” , it will be necessary to set the working range, i.e., values for the lower value (0%/4mA) and the upper value (100%/20mA) of the range.

For the “Others” option it is necessary to set the index required to work. For each device there is a different index list for the #33 command. Each of them relates to a device variable.

**Retries**- This option sets the number of communication retries for the HCC301 performs when there is no answer from the slave device before it is necessary to go to the value configured in FailSafe.

**Address** - This option sets the address of the slave device that will communicate with the HCC301 when it is working as a master. The valid multidrop addresses are from 0 to 15. The HCC301 address must be different from the device to whom it is connected.

**Status Cheching** – This option enables on disables the cheching of the following status on the HCC301 “PV out of limits” and “non-PV out of limits”.

**Model**- The model described the HCC301 code, according to the technical specifications.

Figure 1- Setting the range

Figure2- Setting Safety

### 5 - Trim (Calibration)

When the microprocessor sends a 0 % signal to the output, the Digital/Analog converter (DAC) and the associated electronic components supply a 4mA output. For a 100 % the output will be 20 mA.

To make the HCC301 trim, it is necessary to use a precision ammeter in series with the power supply. Whenever the value indicated is different from the desired value, it is required to insert the value indicated in the ammeter so that the HCC301 can make the current correction. If the current still is not correct, it is necessary to insert again the value displayed in the ammeter until the value is correct.

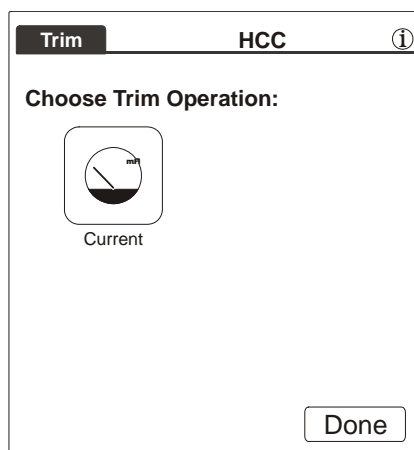

Figure 3 - The trim operation

## 6 - Manut (Maintenance)

**Identification** - This option sets the model and serial number. The model describes the HCC301 code according to the technical specifications. The serial number is the number written in the identification label of the HCC301. This number must be changed whenever the board is replaced.

**Password** - Passwords may be set for all programming tree branches. If the password is enabled, it is possible to read the configuration in INFO, CONF, TRIM, MANUT without the password.

There are three levels of passwords. They are used to restrict the access to certain operations in the programming tree. The 3\_level password is in a superior hierarchy level compared to the level\_2 password, that is superior to the level\_1 password.

**Conf\_Level** - This option allows to change the password level to each type of operation (1 to 3). The configuration of the password levels is stored in the EEPROM of the HCC301.

**Prot\_Written** - This characteristic is used to protect the HCC301 configuration from changes through communication.

## 7 - Applications

The HCC301 continuously polls one variable from another HART device and converts it to a dynamically updated 4-20 mA according to a pre-configured range. The polled variable may be the primary variable, primary variable in percentage or one of the dynamic variables: secondary, tertiary and fourth.

The HCC301 can also read any device variable available from most devices. The real-time information that now can be extracted from these smart devices can be very valuable.

For example, the HCC301 can be used with the DT301 multivariable density transmitter to get a current output for process temperature.

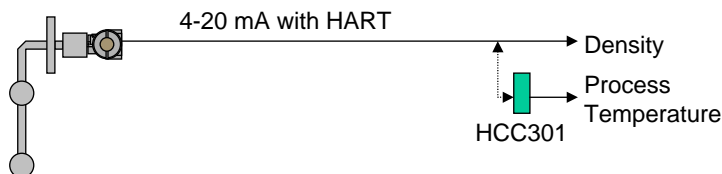

Figure 4- Using the HCC301 with the DT301 transmitter.

The HCC301 can be also used with the FY301 control valve positioner to get an actual valve position feedback current signal for the DCS or PLC. The control strategy can therefore detect a stuck control valve improving safety, provide bumpless transfer all the way down to the valve minimizing process upsets, can be used to detect hunting or sluggish valve performance etc.

Most conventional electro-pneumatic valve positioners do not have any actual valve position feedback and traditionally require installation of a second device, a position transmitter, with its own set of levers and wires etc. to provide feedback to the control room. In fact, a vast majority of control valves have no feedback at all, so operators are unaware if the valve is moving as it is supposed to, is stuck, or is otherwise misbehaving. FY301 with HCC301 makes it possible for the operator at the DCS or PLC to know that the controller output is actually taking effect.

The safety of the control loop is greatly improved. Some positioners indeed have an optional analog feedback output board. However, this output requires additional wires, effectively doubling the number of wires required. Adding position feedback as an afterthought is very difficult with such positioner. Feedback through HCC301 is easily added to an FY301 already installed.

The HCC301 mounts in the control room panel and requires no running of additional wires into the field and no modification whatsoever to the FY301.

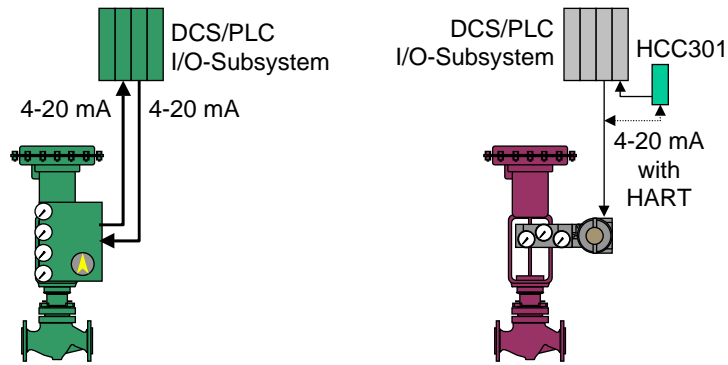

**Figure 5: In the past feedback required additional wires (left) but not using HCC301 (right)**

The HCC301 can also be used with the TT301 or LD301 when these are in controller mode, in order to simultaneously also get the process variable to display in a panel meter. The fast 4-20 mA signal goes to the control valve while HCC301 polls the transmitter for the process value and converts it to a reading displayed in a regular panel meter.

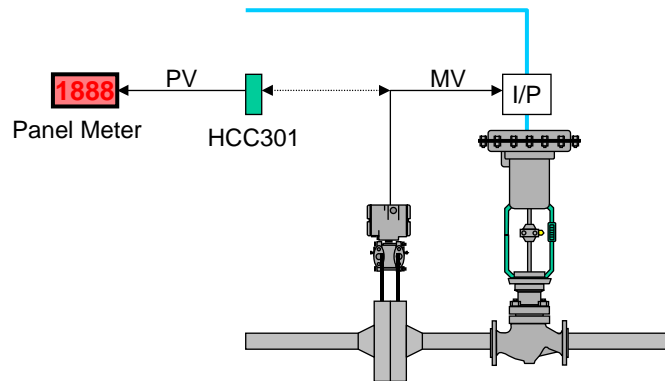

**Figure 6- Using the HCC301 with the TT301 and LD301 transmitters.**

## 8 - Technical Specifications

**Accuracy:**

The accuracy of the variable converted will be 0.040 % of the span.

**Temperature Effect:**

0.2 % in the output current from -40°C to +85°C.

**Power Supply:**

12 to 45 Vdc in the 4 to 20 mA. This voltage will supply the HCC301.

**Communication:**

Via HART, passive MAU and isolation of 1500 Vdc.

**Response time:**

Updating of the read variable within 120 ms.

The next figures show the connecting scheme, terminal board and HCC301 dimensions.

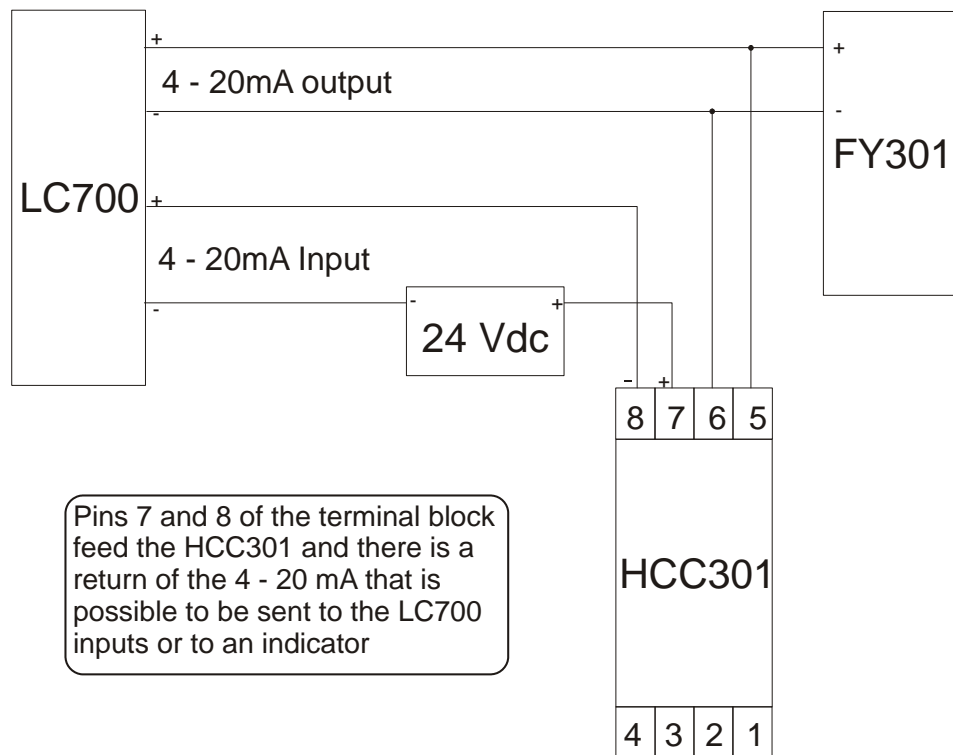



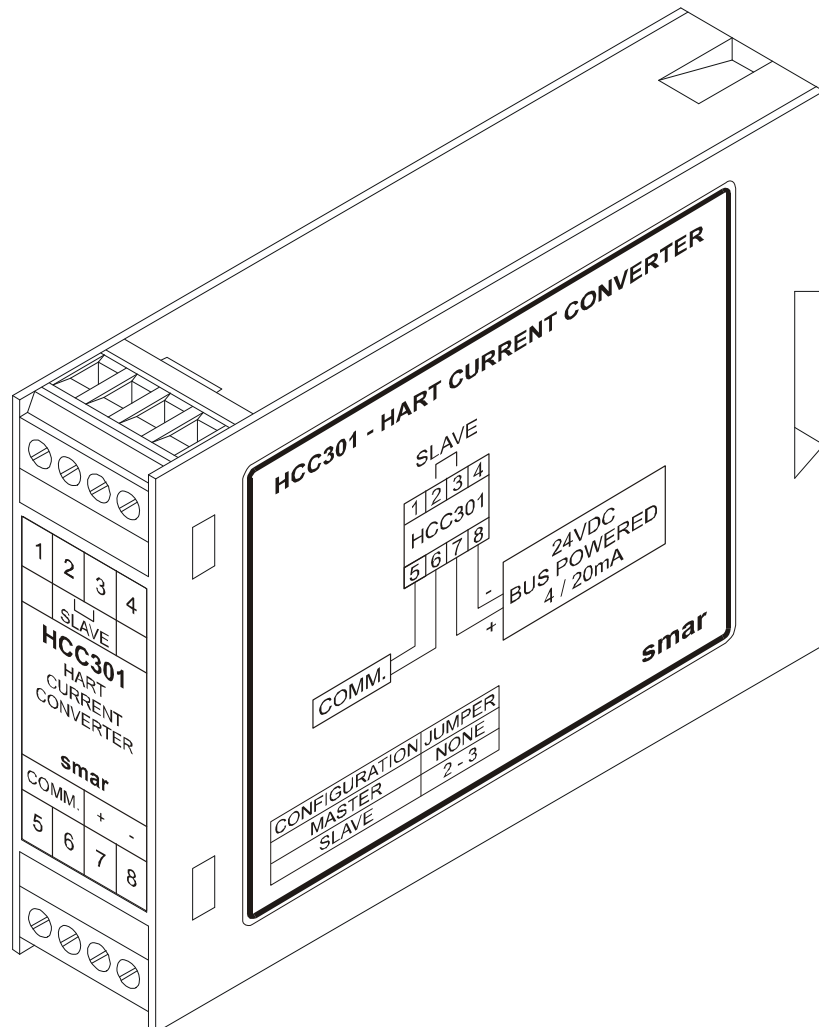
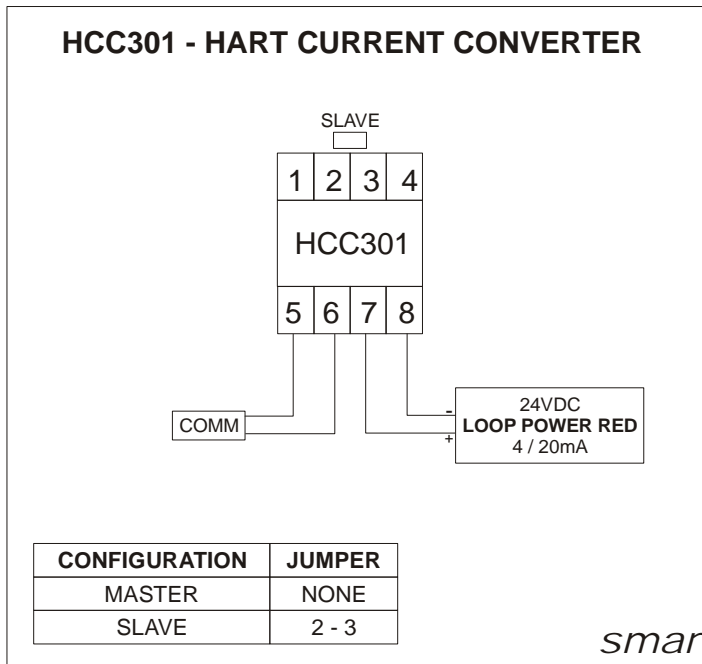

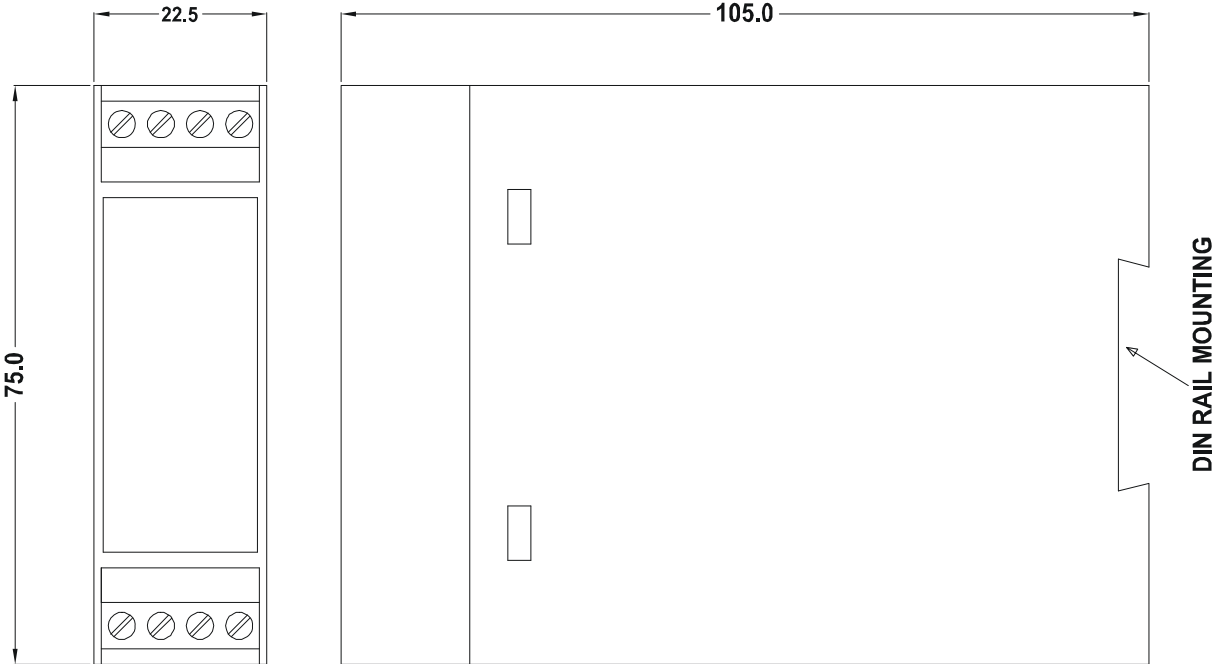

# Appendix A



## SRF – Service Request Form

HCC301 - Converter from HART® to 4-20mA

### GENERAL DATA

**Model:** HCC301 ( )      **Firmware Version:** \_\_\_\_\_  
**Serial Number:** \_\_\_\_\_  
**TAG:** \_\_\_\_\_  
**Calibration**      **Range:** \_\_\_\_\_      **Variable:** \_\_\_\_\_      **Unit:** \_\_\_\_\_  
**Configuration:** PC ( )      **Software:** \_\_\_\_\_      **Version:** \_\_\_\_\_

### PROCESS DATA

**Types of Interference presents in the area:**      Without interference ( )      Temperature ( )      Vibration ( )      Others: \_\_\_\_\_  
**Ambient Temperature:**      From \_\_\_\_\_°C up to \_\_\_\_\_°C.  
**Others:** \_\_\_\_\_

### SITUATION DESCRIPTION

\_\_\_\_\_  
\_\_\_\_\_  
\_\_\_\_\_  
\_\_\_\_\_

### SERVICE SUGGESTION

Adjustment ( )      Cleaning ( )      Preventive Maintenance ( )      Update / Up-grade ( )  
**Other:** \_\_\_\_\_

### USER INFORMATION

**Company:** \_\_\_\_\_  
**Contact:** \_\_\_\_\_  
**Title:** \_\_\_\_\_  
**Section:** \_\_\_\_\_  
**Phone:** \_\_\_\_\_      **Extension:** \_\_\_\_\_  
**E-mail:** \_\_\_\_\_      **Date:** \_\_\_\_/\_\_\_\_/\_\_\_\_

For warranty or non-warranty repair, please contact your representative.  
Further information about address and contacts can be found on [www.smar.com/contactus.asp](http://www.smar.com/contactus.asp).

## ***Returning Materials***

Should it become necessary to return the converter and/or configurator to SMAR, simply contact our office, informing the defective instrument serial number, and return it to our factory.

In order to speed up analysis and solution of the problem, the defective item should be returned with a description of the failure observed, with as much details as possible. Other information concerning the instrument operation, such as service and process conditions, is also helpful.

Instruments returned or to be revised outside the guarantee term should be accompanied by a purchase order or a quote request.

## SMAR WARRANTY CERTIFICATE

1. SMAR guarantees its products for a period of 24 (twenty four) months, starting on the day of issuance of the invoice. The guarantee is valid regardless of the day that the product was installed.
2. SMAR products are guaranteed against any defect originating from manufacturing, mounting, whether of a material or manpower nature, provided that the technical analysis reveals the existence of a quality failure liable to be classified under the meaning of the word, duly verified by the technical team within the warranty terms.
3. Exceptions are proven cases of inappropriate use, wrong handling or lack of basic maintenance compliant to the equipment manual provisions. SMAR does not guarantee any defect or damage caused by an uncontrolled situation, including but not limited to negligence, user imprudence or negligence, natural forces, wars or civil unrest, accidents, inadequate transportation or packaging due to the user's responsibility, defects caused by fire, theft or stray shipment, improper electric voltage or power source connection, electric surges, violations, modifications not described on the instructions manual, and/or if the serial number was altered or removed, substitution of parts, adjustments or repairs carried out by non-authorized personnel; inappropriate product use and/or application that cause corrosion, risks or deformation on the product, damages on parts or components, inadequate cleaning with incompatible chemical products, solvent and abrasive products incompatible with construction materials, chemical or electrolytic influences, parts and components susceptible to decay from regular use, use of equipment beyond operational limits (temperature, humidity, etc.) according to the instructions manual. In addition, this Warranty Certificate excludes expenses with transportation, freight, insurance, all of which are the customer's responsibility.
4. For warranty or non-warranty repair, please contact your representative.

Further information about address and contacts can be found on [www.smar.com/contactus.asp](http://www.smar.com/contactus.asp)

5. In cases needing technical assistance at the customer's facilities during the warranty period, the hours effectively worked will not be billed, although SMAR shall be reimbursed from the service technician's transportation, meals and lodging expenses, as well dismounting/mounting costs, if any.
6. The repair and/or substitution of defective parts do not extend, under any circumstance, the original warranty term, unless this extension is granted and communicated in writing by SMAR.
7. No Collaborator, Representative or any third party has the right, on SMAR's behalf, to grant warranty or assume some responsibility for SMAR products. If any warranty would be granted or assumed without SMAR's written consent, it will be declared void beforehand.
8. Cases of Extended Warranty acquisition must be negotiated with and documented by SMAR.
9. If necessary to return the equipment or product for repair or analysis, contact us.  
See item 4.
10. In cases of repair or analysis, the customer must fill out the Revision Requisition Form (FSR) included in the instructions manual, which contains details on the failure observed on the field, the circumstances it occurred, in addition to information on the installation site and process conditions. Equipments and products excluded from the warranty clauses must be approved by the client prior to the service execution.
11. In cases of repairs, the client shall be responsible for the proper product packaging and SMAR will not cover any damage occurred in shipment.

12. Responsibility: Except for the above-mentioned general warranty conditions for SMAR products, SMAR will not assume any responsibility before the customer, without limitation, for damages, consequences, indemnity claims, loss of earnings, service expenses and other costs caused by the non-observation of the installation, operation and maintenance instructions included in SMAR manuals. Furthermore, the buyer also agrees to exempt the supplier for indemnity of damages (with exception to costs for repairs or the reposition of defective products above described) directly or indirectly caused by inadequate tests, application, operation or repair of SMAR products.
13. It is the customer's responsibility to clean and decontaminate products and accessories prior to shipping them for repair, and SMAR and its dealer reserve themselves the right to refuse the service in cases not compliant to those conditions. It is the customer's responsibility to tell SMAR and its dealer when the product was utilized in applications that contaminate the equipment with harmful products during its handling and repair. Any other damages, consequences, indemnity claims, expenses and other costs caused by the lack of decontamination will be attributed to the client. Kindly, fill out the Declaration of Decontamination prior to shipping products to SMAR or its dealers, which can be accessed at [www.smar.com/doc/declarationofcontamination.pdf](http://www.smar.com/doc/declarationofcontamination.pdf) and include in the packaging.
14. This warranty certificate is valid only when accompanying the purchase invoice.