

smar - FRI303

smar

DEC / 12
FRI303
VERSION 3



OPERATION & MAINTENANCE
INSTRUCTIONS MANUAL

Profibus-PA Remote I/O



FRI 303 ME



Specifications and information are subject to change without notice.
Up-to-date address information is available on our website.

[web: www.smar.com/contactus.asp](http://www.smar.com/contactus.asp)

INTRODUCTION

The **FRI303** is a Profibus-PA device that has two built-in relays making integration of Profibus-PA to conventional devices such as solenoids, on/off valves, electrical actuators, motors, pumps, starters, etc. The **FRI303** also has two dry contact inputs. The **FRI303** Profibus-PA Remote I/O can be located in the field, mounted close to the conventional devices without the need to run the conventional wiring to the control room. The **FRI303** is an integral part of SYSTEM302 but also integrates into other systems that support Profibus-PA.

The **FRI303** allows that conventional discrete outputs be available, in order to make the control strategy configuration easy. Using standard Profibus-PA Function blocks, these outputs appear as regular Profibus-PA devices, thus making the system homogenous. Control loops are implemented consistently.

Function blocks for input and output are available for **FRI303** and provide great flexibility in the control strategy. The **FRI303** is fully configured from SYSTEM302 or any other Profibus-PA configuration tool.

The **FRI303** may be installed close to the discrete devices, thereby eliminating long wire runs, associated marshaling panels and cable trays for the conventional output. With subsequent savings further reducing overall system costs. The use of **FRI303** makes it possible to distribute outputs at various locations in the field and connect them via the Profibus-PA.

Get the best result of the FRI303 by carefully reading these instructions.

WARNING

This Manual is compatible with version 3.XX, where 3 denotes software version and XX software release. The indication 3.XX means that this manual is compatible with any release of software version 3.

Waiver of responsibility

The contents of this manual abides by the hardware and software used on the current equipment version. Eventually there may occur divergencies between this manual and the equipment. The information from this document are periodically reviewed and the necessary or identified corrections will be included in the following editions. Suggestions for their improvement are welcome.

Warning

For more objectivity and clarity, this manual does not contain all the detailed information on the product and, in addition, it does not cover every possible mounting, operation or maintenance cases.

Before installing and utilizing the equipment, check if the model of the acquired equipment complies with the technical requirements for the application. This checking is the user's responsibility.

If the user needs more information, or on the event of specific problems not specified or treated in this manual, the information should be sought from Smar. Furthermore, the user recognizes that the contents of this manual by no means modify past or present agreements, confirmation or judicial relationship, in whole or in part.

All of Smar's obligation result from the purchasing agreement signed between the parties, which includes the complete and sole valid warranty term. Contractual clauses related to the warranty are not limited nor extended by virtue of the technical information contained in this manual.

Only qualified personnel are allowed to participate in the activities of mounting, electrical connection, startup and maintenance of the equipment. Qualified personnel are understood to be the persons familiar with the mounting, electrical connection, startup and operation of the equipment or other similar apparatus that are technically fit for their work. Smar provides specific training to instruct and qualify such professionals. However, each country must comply with the local safety procedures, legal provisions and regulations for the mounting and operation of electrical installations, as well as with the laws and regulations on classified areas, such as intrinsic safety, explosion proof, increased safety and instrumented safety systems, among others.

The user is responsible for the incorrect or inadequate handling of equipments run with pneumatic or hydraulic pressure or, still, subject to corrosive, aggressive or combustible products, since their utilization may cause severe bodily harm and/or material damages.

The field equipment referred to in this manual, when acquired for classified or hazardous areas, has its certification void when having its parts replaced or interchanged without functional and approval tests by Smar or any of Smar authorized dealers, which are the competent companies for certifying that the equipment in its entirety meets the applicable standards and regulations. The same is true when converting the equipment of a communication protocol to another. In this case, it is necessary sending the equipment to Smar or any of its authorized dealer. Moreover, the certificates are different and the user is responsible for their correct use.

Always respect the instructions provided in the Manual. Smar is not responsible for any losses and/or damages resulting from the inadequate use of its equipments. It is the user's responsibility to know and apply the safety practices in his country.

TABLE OF CONTENTS

SECTION 1 - INSTALLATION	1.1
GENERAL	1.1
MOUNTING	1.1
ELECTRIC WIRING	1.2
TOPOLOGY AND NETWORK CONFIGURATION	1.7
GENERAL SYSTEM	1.9
SECTION 2 - OPERATION	2.1
FUNCTIONAL DESCRIPTION – ELECTRONICS	2.1
(CPU) CENTRAL PROCESSING UNIT, RAM AND FLASH	2.1
COMMUNICATION CONTROLLER	2.1
POWER SUPPLY	2.1
INPUT LATCHES	2.1
OUTPUT LATCHES	2.1
LOCAL ADJUSTMENT	2.1
OPTICAL ISOLATION	2.1
SECTION 3 - CONFIGURATION	3.1
CONNECTING PHYSICAL SIGNALS TO DI (DIGITAL INPUT) BLOCK AND DO (DIGITAL OUTPUT) BLOCK	3.1
APPLICATION EXAMPLES	3.2
FRI303 CYCLICAL CONFIGURATION	3.4
CYCLICAL DIAGNOSIS	3.6
SECTION 4 - MAINTENANCE PROCEDURES	4.1
GENERAL	4.1
DISASSEMBLY PROCEDURE	4.1
REASSEMBLY PROCEDURE	4.2
FIRMWARE UPDATE PROCEDURE	4.2
ACCESSORIES	4.2
EXPLODED VIEW	4.3
SPARE PARTS	4.3
SECTION 5 - TECHNICAL SPECIFICATIONS	5.1
GENERAL	5.1
FRI303 OUTPUT RELAYS	5.1
TECHNICAL SPECIFICATIONS FOR NORMALLY CLOSED RELAYS	5.1
TECHNICAL SPECIFICATIONS FOR NORMALLY OPENED RELAYS	5.2
TECHNICAL SPECIFICATIONS FOR DRY CONTACT INPUT	5.2
ORDERING CODE	5.3
APPENDIX A - SRF – SERVICE REQUEST FORM	A.1
SERVICE REQUEST FORM	A.2

Installation Flowchart

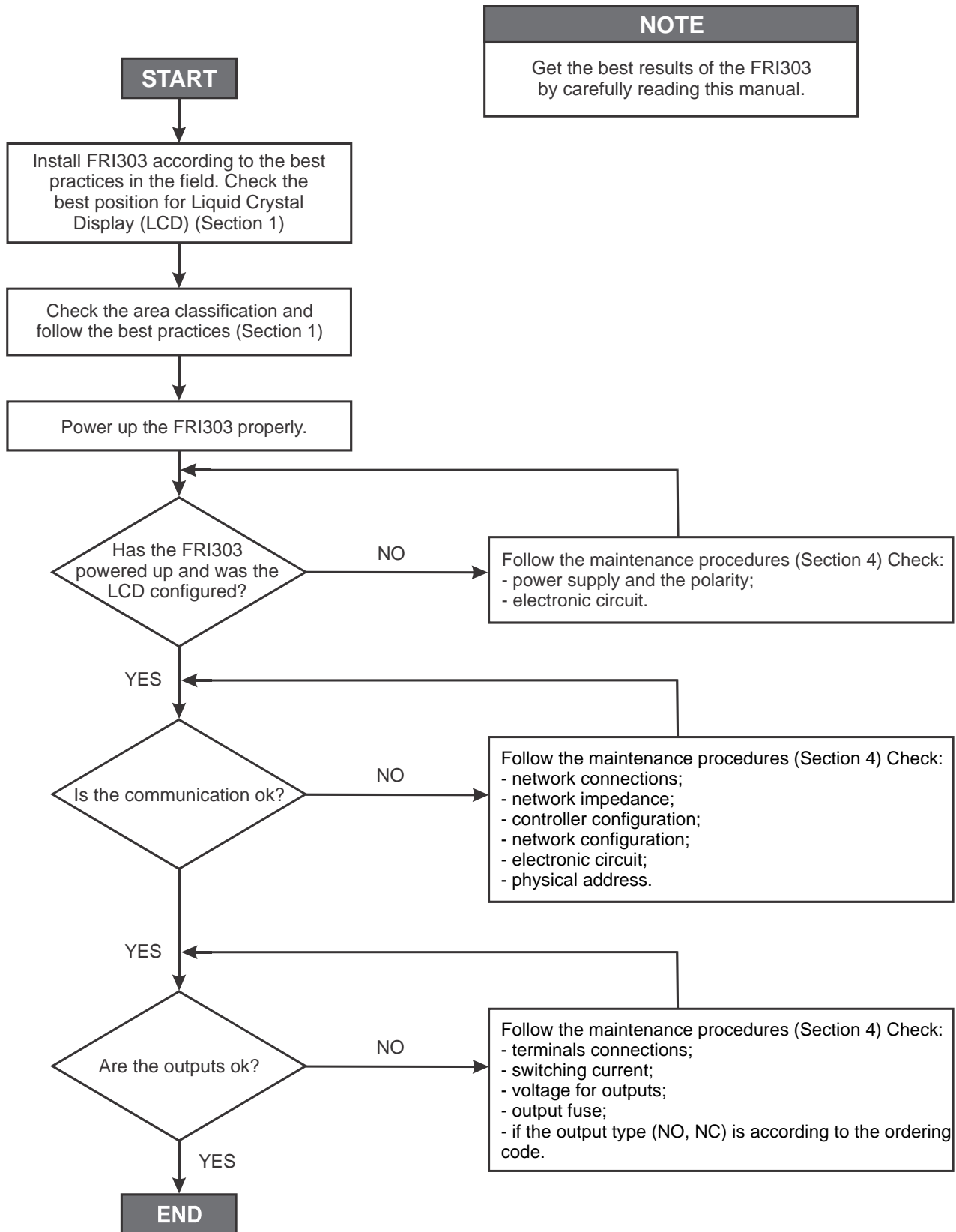

*More information in Section 1 of **FRI303**. Operation, Maintenance and Instructions Manual.

Section 1

INSTALLATION

General

The overall reliability of actuation and control depends on several variables. Although the **FRI303** has an outstanding performance, proper installation is essential in order to maximize its performance.

Among all factors, which may affect the accuracy, the environmental conditions are the most difficult to control. There are, however, ways of reducing the effects of temperature, humidity and vibration. Locating the **FRI303** in areas protected from extreme environmental changes can improve its performance.

In warm environments, the **FRI303** should be installed to avoid, as much as possible, direct exposure to the sun. Installation close to lines and vessels subjected to high temperatures also should be avoided.

The use of sunshades or heat shields to protect the **FRI303** from external heat sources should be considered, when necessary.

Humidity can be fatal to electronic circuits. A humidity proof coating protects the electronic circuit, but frequent exposures to humidity may affect the protection provided. It is also important to keep the covers tightened in place. Every time they are removed, the threads are exposed to corrosion, since painting cannot protect these parts. Code-approved sealing methods on conduit entering the converter should be employed.

For details of mounting, please, refer to Figure 1.1.

Mounting

Using the bracket, the mounting may be done in several positions, as shown on Figure 1.1 - Dimensional Drawing and Mounting Positions.

For better visibility, the digital indicator may be rotated in steps of 90° (See Section 4 – Maintenance Procedures).

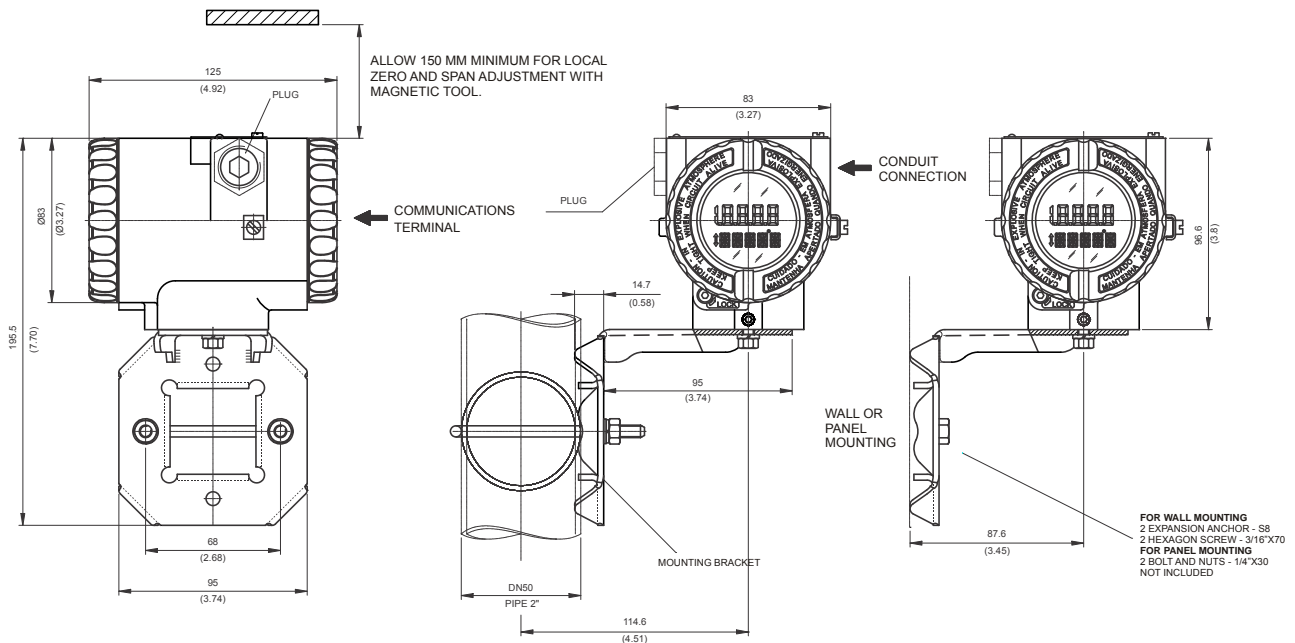

Figure 1.1 - Dimensional Drawing and Mounting Positions

Electric Wiring

Access the wiring block by removing the Electrical Connection Cover. This cover can be locked closed by the cover locking screw (See Figure 1.2 - Cover Locking). To release the cover, rotate the locking screw clockwise.

Cable access to wiring connections is obtained by one of the two conduit outlets. Conduit threads should be sealed by means of code-approved sealing methods. The unused outlet port should be plugged accordingly.

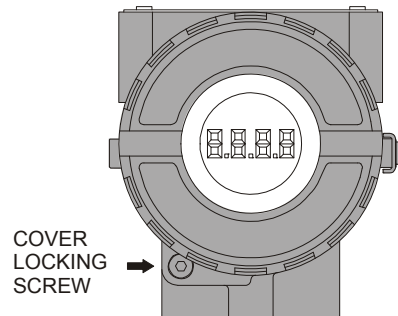

Figure 1.2 - Cover Locking

The wiring block has screws, on which fork or ring type terminals can be fastened. See Figure 1.3 – Terminal Block.

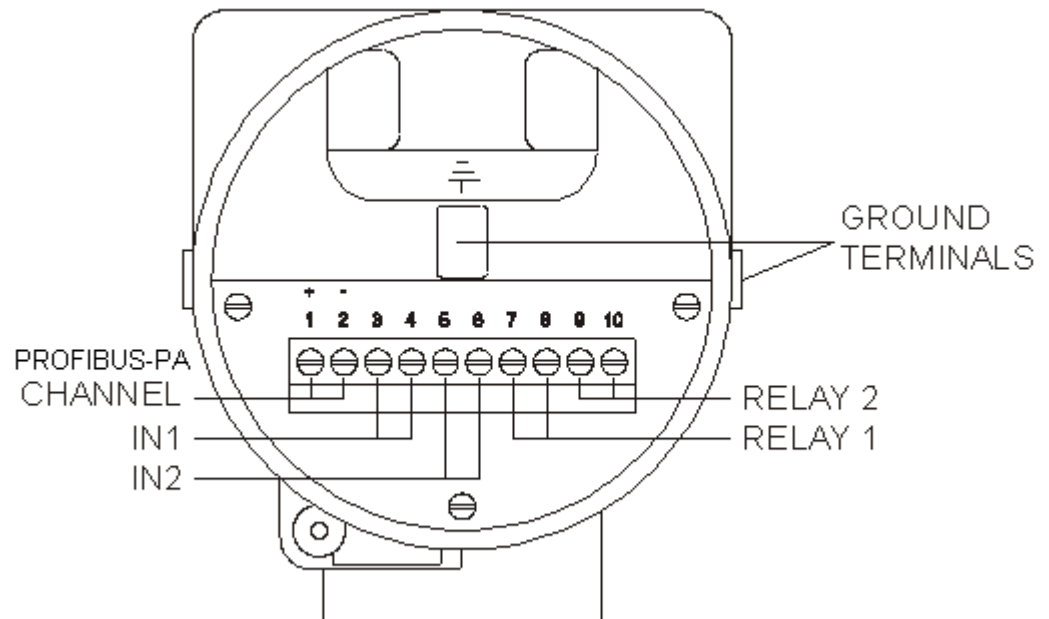

Figure 1.3 – Terminal Block

For convenience there are three ground terminals: one inside the cover and two externals, located close to the conduit entries.

The unused port should be plugged accordingly. In Figure 1.4 you can see an example of output connections.

FRI303

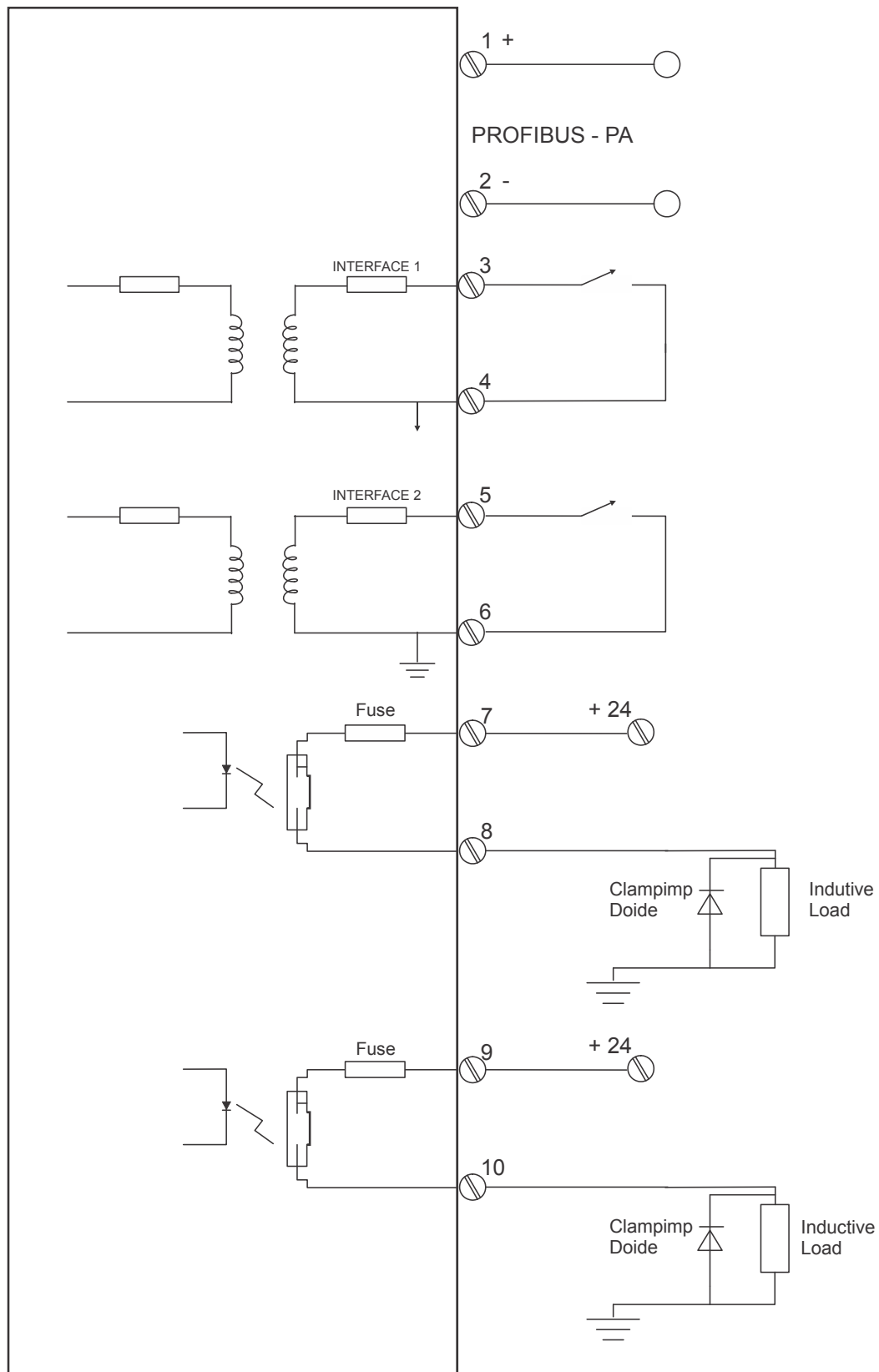

Figure 1.4 - Example of Output and Input Connections

The FRI303 is a bus-powered device.

The FRI303 uses the 31.25 kbit/s voltage mode option for the physical signaling. Various types of Profibus-PA devices may be connected on the same bus being bus-powered or non-bus-powered.

When bus-powered, the devices must use the same signaling.

In hazardous areas, the number of devices may be limited by intrinsically safe restrictions.

The FRI303 is protected against reverse polarity, and can withstand ± 35 VDC without damage.



NOTE

For a DC connection it is recommended to use a protection diode and for an AC connection it is recommended to use a snubber, mainly for inductive loads.

Surge Suppression

Transient EMI (electric noise) can be generated during the commutation of every inductive electric load. In many cases, the noise interferes directly on the origin of the commutation command and until may damage electronic components. Those transient peaks have a time of ascent very fast, generating a high induced tension where the automation wiring system works as the signal transmitter and receiver due to their capacitance.

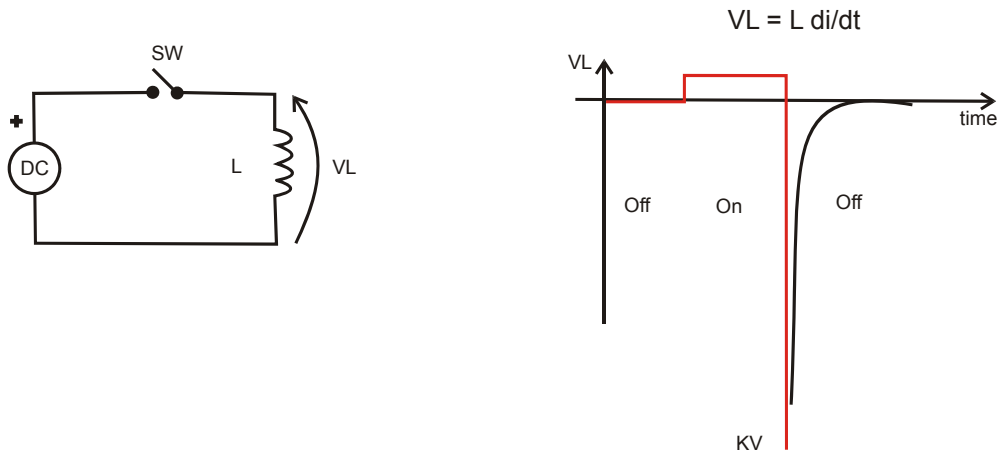

Figure1.5 – Reverse Voltage Peak

Some alternatives may avoid this interference, like optical couplers, Zero Crossing Switching, indirect startups that prevent the arrival of the noise to the command, but the noise generated by the commuted device continues existing and many times it is induced in the wiring system, reaching other automation electronic points, causing intermittent defects in the system. Therefore, those ways of treating the noise are not effective. It should be eliminated exactly in the noise source, in other words, in order to obtain a filter with better performance, it should be mounted the closest possible to the commuted load.

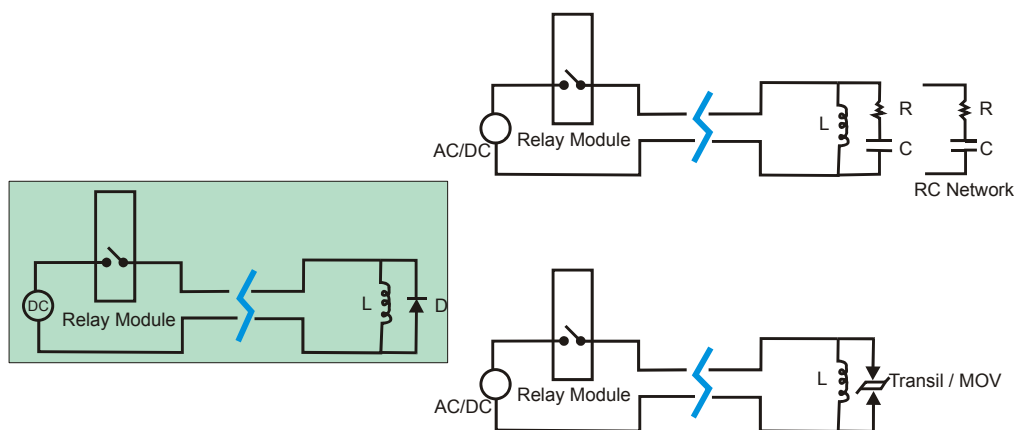

Figure 1.6 – Filters for AC and DC loads

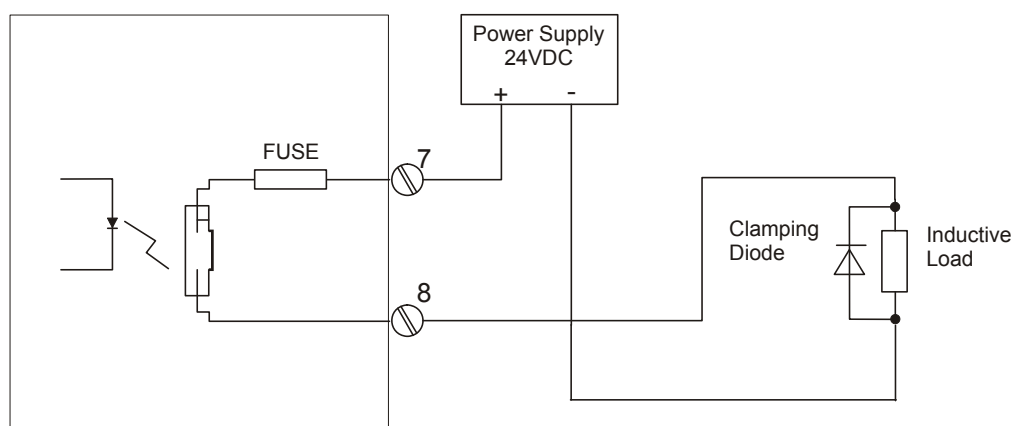

Figure 1.7 – Protection Diode in Parallel to DC Load

- **Inductive AC Load:** In FRI303 it is recommended to insert snubber circuit in parallel to the load and close to them. This will avoid the noise coupling in other cables that are in the same conduit.

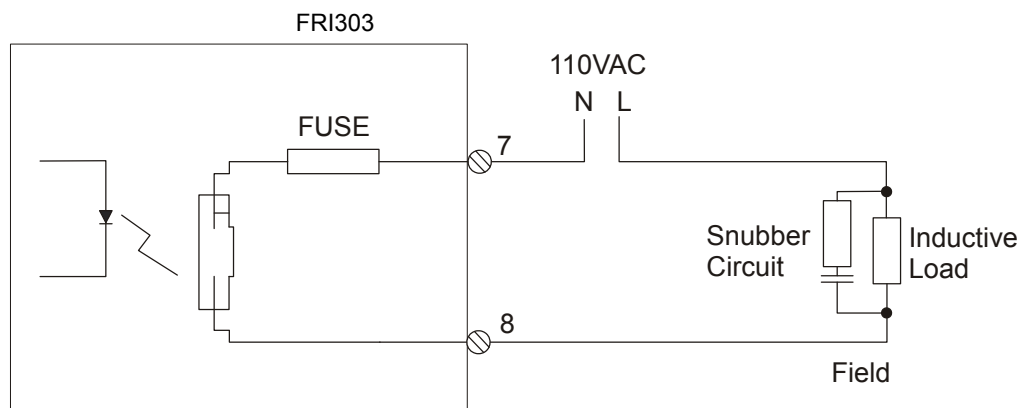

Figure 1.8 – Snubber Circuit in parallel to the AC Load

Suggestion for the RC network components and the clamping diode

The maximum current of the clamping diode should be greater or equal to the load maximum current, and the maximum tension should be 3-4 times greater than the circuit source in 24VDC and 8-10 times greater than the circuit source in 110VDC.

The RC circuit (AC) capacitor should have a tension 2-3 times greater than the power supply voltage. Recommended values:

LOAD INDUCTANCE	CAPACITOR
25-70 mH	0.50 μ F
70-180 mH	0.250 μ F
180 mH - 10H	0.10 μ F

For loads up to 100 Ω , the RC circuit resistor should be 1 - 3 Ω , 2 Watts.
 For loads that exceed 100 Ω , the resistor value should be increased until 47 Ω , 1/2 Watt.

Several manufacturers supply RC filters ready to be mounted in contactors, valves and other inductive loads. One of them is Murr Elektronik (www.murrelektronik.com) or ICOS (www.icos.com.br).

Ferrite Beads

Ferrite beads can supply additional suppression for EMI transients. The Ferrite of Fair-Rite Products Corporation (ordering code 2643626502) can be used in category 2 and 3 conductors. We can install them using fastening belts. With a ferrite located close to the cable termination, EMI transients induced on the cable can be suppressed by the ferrite, before entering in the equipment.

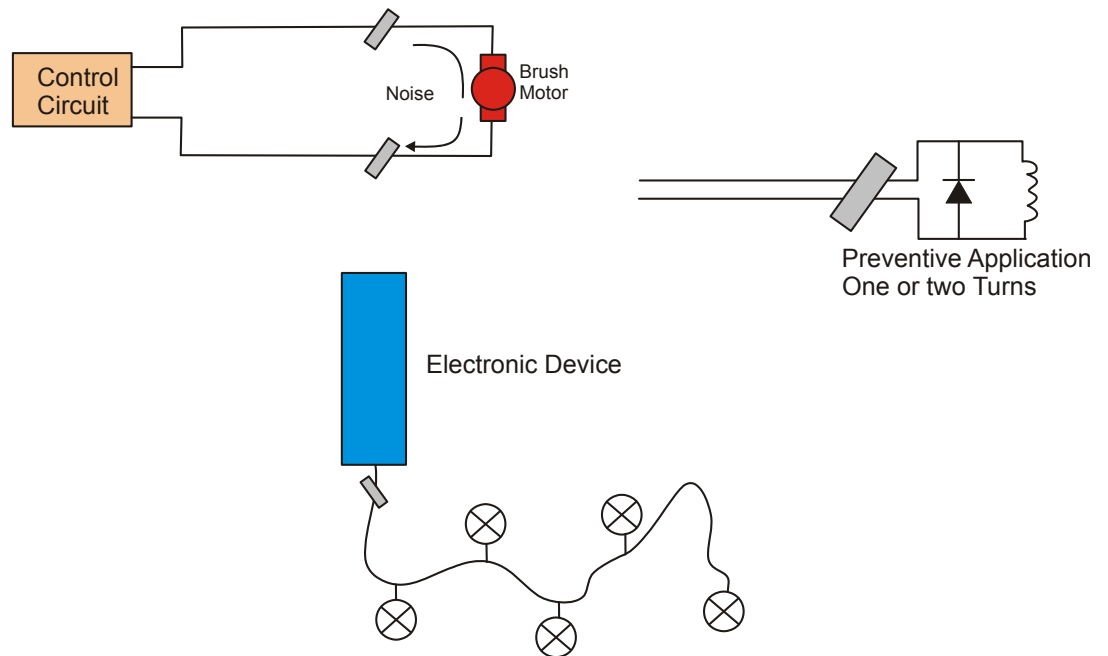

Figure 1.9 – Ferrite Application on Control Lines

NOTE

Please refer to the General Installation, Operation and Maintenance Manual for more details.

WARNING

In hazardous areas with explosion proof requirements, the covers must be tightened at least 8 turns. In order to avoid the penetration of moisture or corrosive gases, tighten the O-ring until it touches the housing. Then, tighten 1/3 turn (120°) more to guarantee sealing. Lock the covers using the locking screw.

In hazardous zones with intrinsically safe or non incandive requirements, the circuit entity parameters and applicable installation procedures must be observed.

Cable access to wiring connections is obtained by one of the two conduit outlets. Conduit threads should be sealed by means of code-approved sealing methods. The unused outlet connection should be plugged and sealed accordingly.

Explosion proof, non incandive and intrinsic safety Factory Mutual certification are standard for **FRI303**.

Should other certifications be necessary, refer to the certification or specific standard for installation limitations.

The Figure 1.10 - Conduit Installation Diagram, shows the correct installation of the conduit, in order to avoid penetration of water, or other substance, which may cause malfunctioning of the equipment.

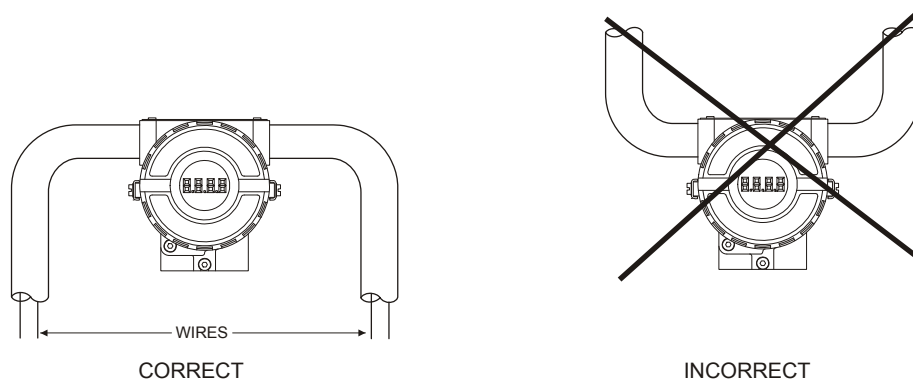

Figure 1.10 - Conduit Installation Diagram

Topology and Network Configuration

Bus topology (See Figure 1.11 - Bus Topology) and tree topology (See Figure 1.12 - Tree Topology) are supported. Both types have a trunk cable with two terminations. The devices are connected to the trunk via spurs. The spurs may be integrated in the device giving zero spur length. A spur may connect more than one device, depending on the length. Active couplers may be used to extend spur length.

Active repeaters may be used to extend the trunk length.

The total cable length, including spurs, between any two devices in the Profibus-PA should not exceed 1900 m.

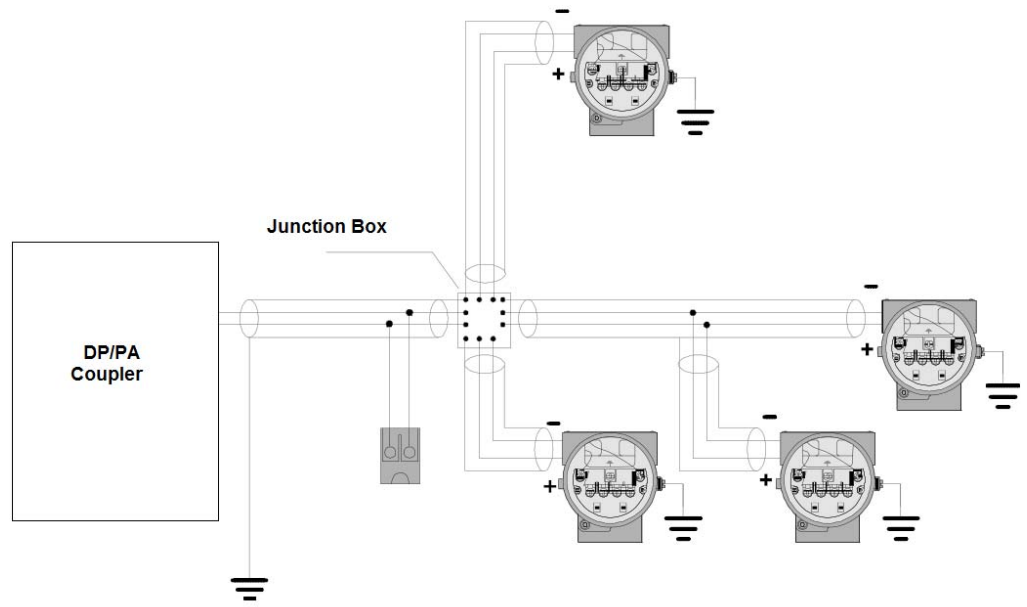

Figure 1.11 - Bus Topology

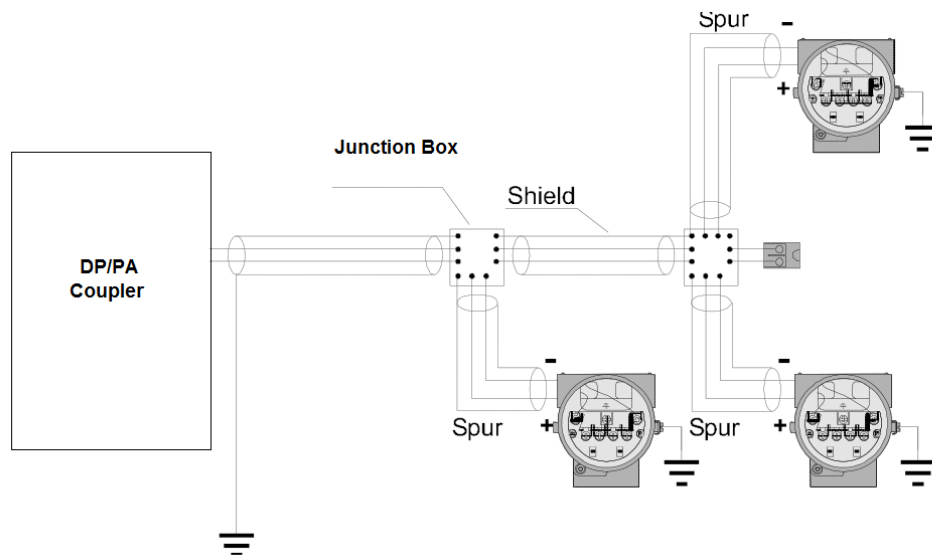

Figure 1.12 - Tree Topology

General System

According to the figure below, a general network topology can be seen where the **FRI303** is integrated into a simple Profibus-PA network.

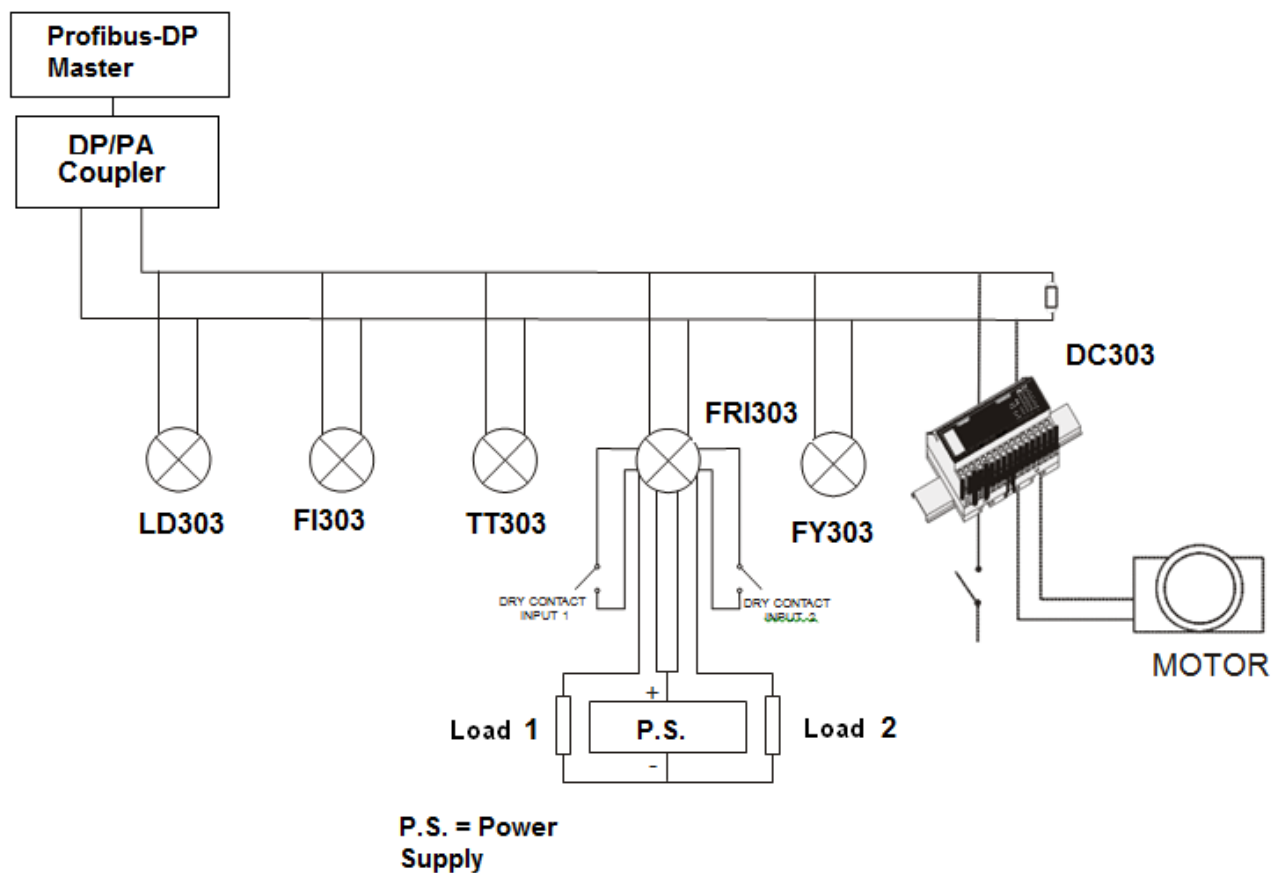

Figure 1.13 – FRI303 and a general Profibus-PA System

OPERATION

The **FRI303** has 2 isolated built-in relay outputs and two dry contact inputs. It is therefore ideal for interfacing existing discrete devices to a Profibus-PA system.

Output function blocks include standard Profibus-PA safety mechanisms in case of failures. Outputs are isolated from each other.

NOTE

For each output there is a 250mA protection fuse. To access them, please, remove the main electronic board and in the Relay board see the reference FU1 and FU2. The code for them is LIT 251.250 – 0.250 A – from Littelfuse.

Functional Description – Electronics

Refer to the block diagram (See Figure 2.1 – **FRI303** Block Diagram). The function of each block is described below.

(CPU) Central Processing Unit, RAM and FLASH

The CPU is the intelligent portion of the Profibus-PA Relay and dry contact Input, being responsible for the management and operation of block execution, self-diagnostics and communication. The program is stored in Flash memory. For temporary storage of data there is a RAM. The data in the RAM is lost if the power is switched off. However, the device also has a nonvolatile EEPROM where data that must be retained are stored. Examples of such data are configuration and identification data.

Communication Controller

It monitors line activity, modulates and demodulates the signal from the network.

Power Supply

Takes power of the loop-line to power the converter circuitry.

Display Controller

Receives data from the CPU and drives the Liquid Crystal Display.

Input Latches

Store the information of the inputs' conditions.

Output Latches

Store the information of the outputs' conditions.

Local Adjustment

There are two switches that are magnetically activated. They can be activated by the magnetic tool without mechanical or electrical contact.

Optical Isolation

Optical isolation is for outputs and inputs.

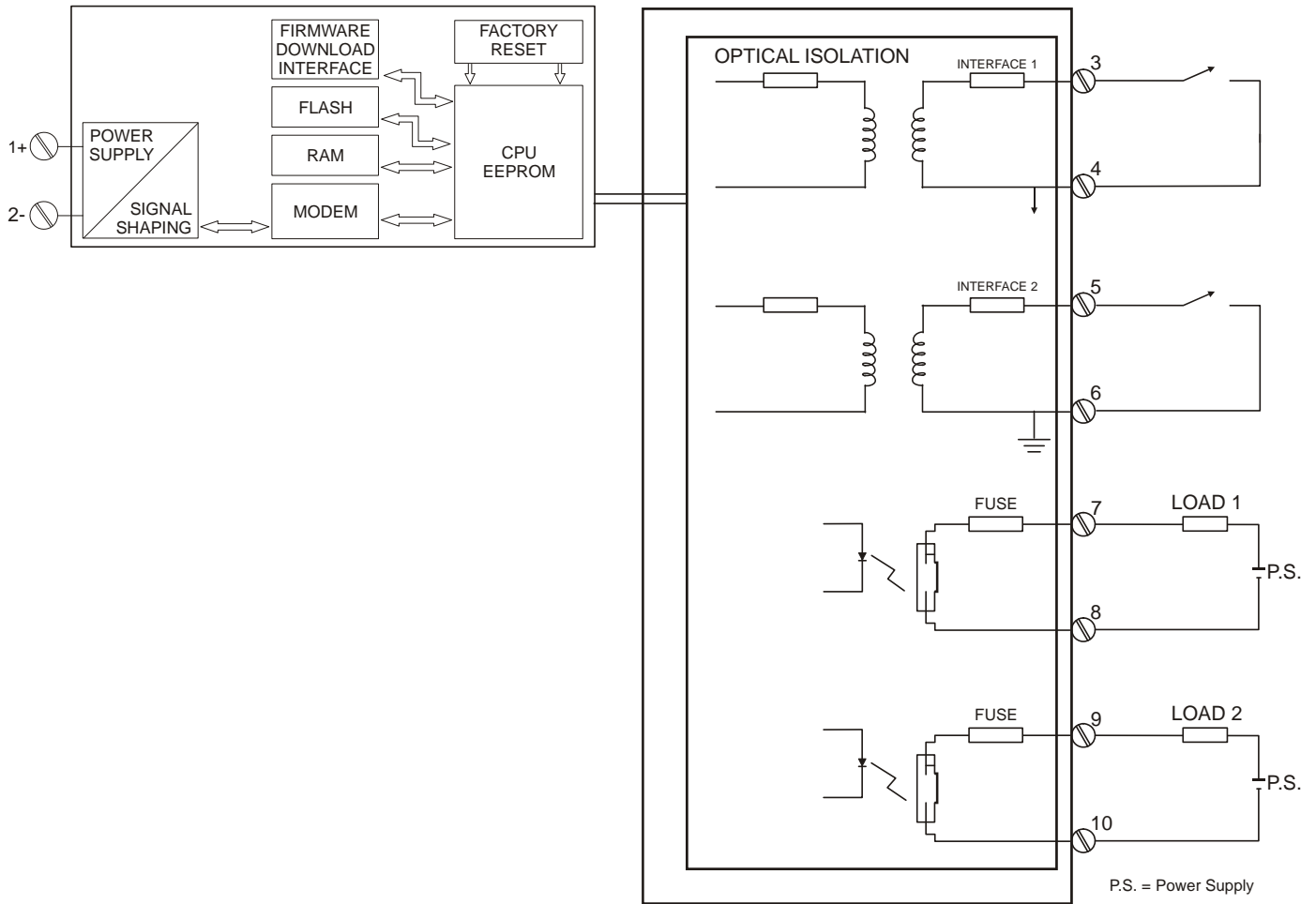

Figure 2.1 – FRI303 Block Diagram

NOTE

When the FRI303 has a N.O. relay and a N.C. relay, the N.O. relay is connected to terminals 7-8 and the N.C. relay in the terminals 9-10.

CONFIGURATION

One of the many advantages of Profibus-PA is that device configuration is independent of the configuration tool. The **FRI303** may be configured by a third party host computer using the EDDL (Device Description) or FDT/DTM tools.

The **FRI303** has 02 DIs (Discrete Input) and 02 DOs (Discrete Output) blocks.

Function Blocks are not covered in this manual. For explanation and details of function blocks, see the *Function Blocks Manual*.

Connecting physical signals to DI (Digital Input) Block and DO (Digital Output) Block

The DI block takes the discrete input data, selected by channel number, and makes it available to other function blocks at its output. The DO block converts the value in SP_D to something useful for the hardware through the CHANNEL selection.

For details, please see the Function Blocks Manual.

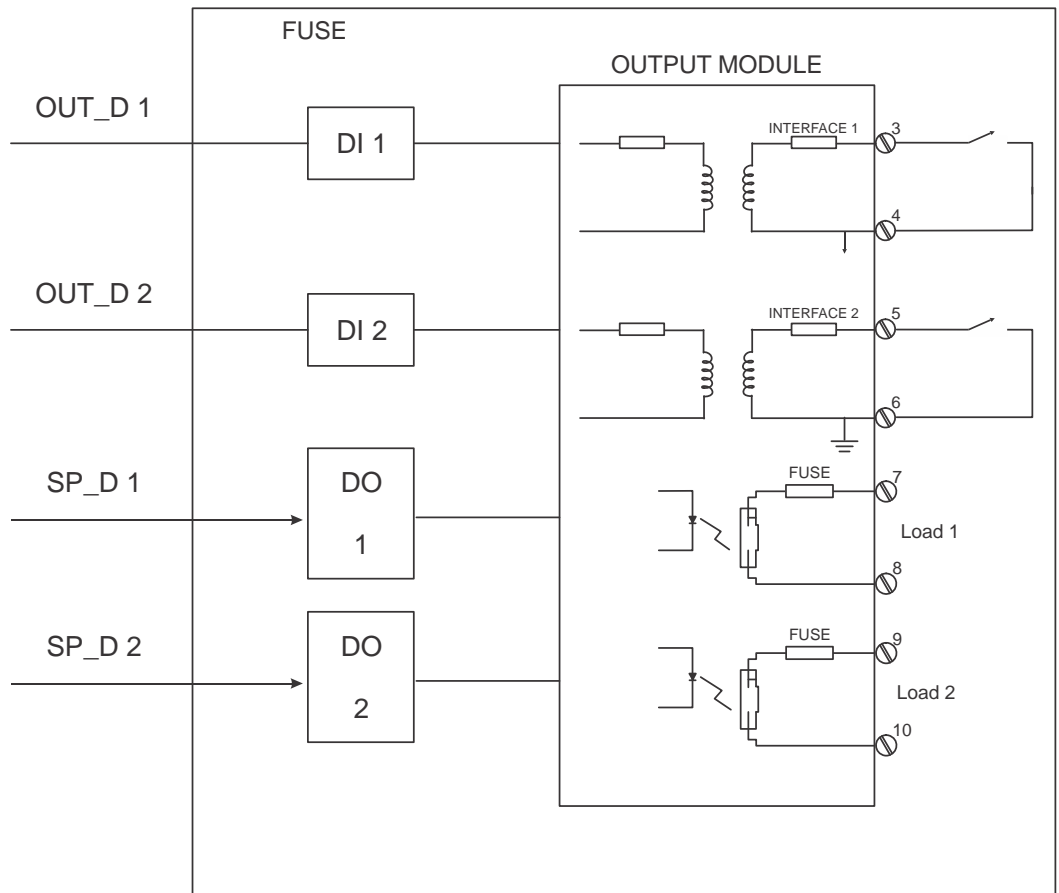

Figure 3.1 – FRI303 - Connections with the DI and DO Blocks.

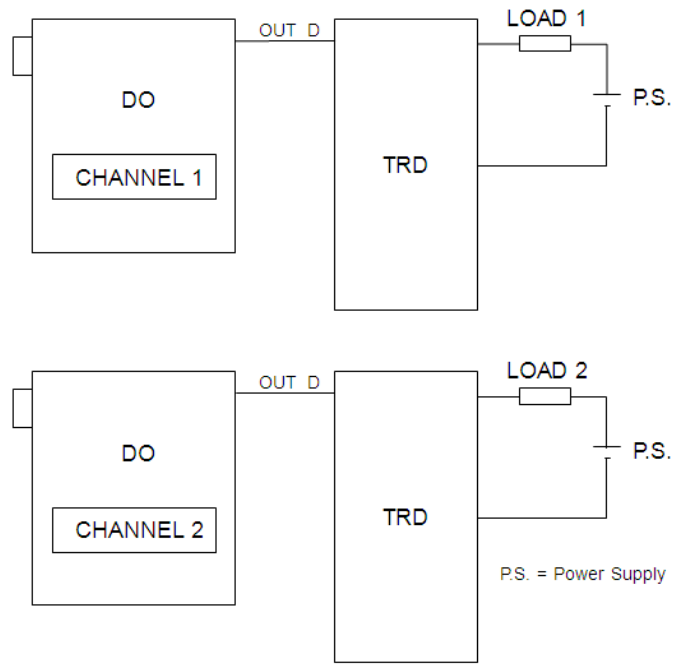

Figure 3.2 - FRI303 and DO Block connections

Application Examples

Application 1: the outputs can be manipulated via Profibus-PA network.

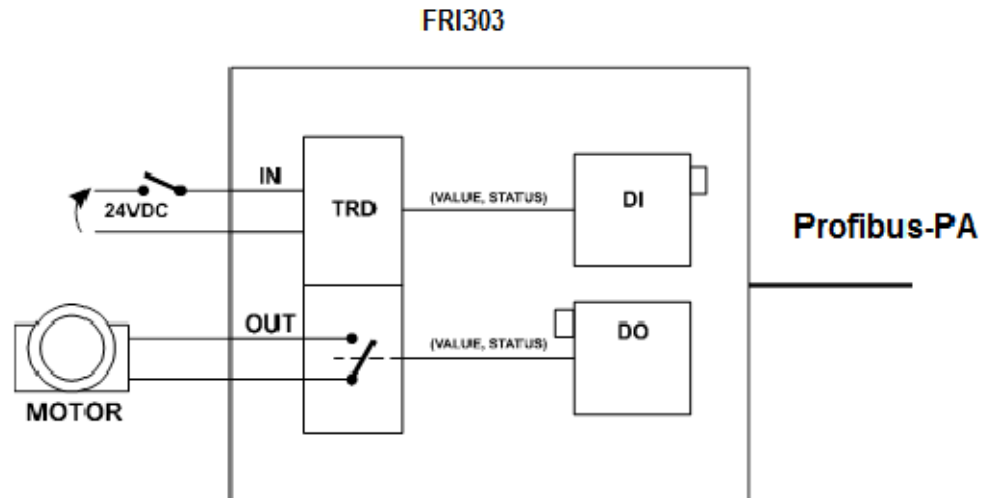

Figure 3.3 - Aplicação 1- FRI303

Application 2: generic application with sensors and actuation.

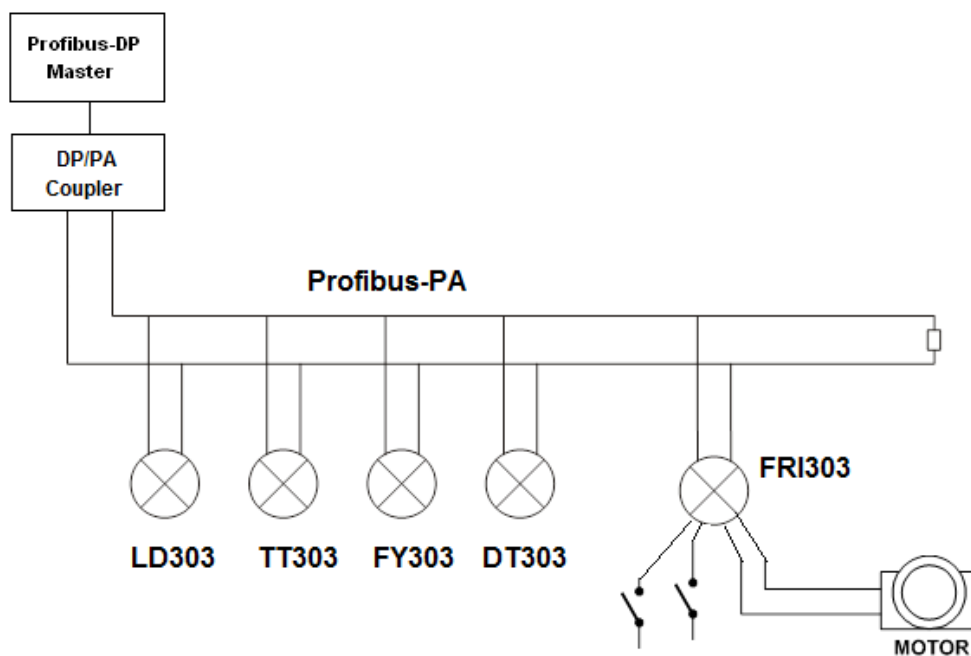

Figure 3.4 - FRI303 – Application 2

Application 3: Level Control (The level limits will trigger the actuation in motor, pump or a valve on / off).

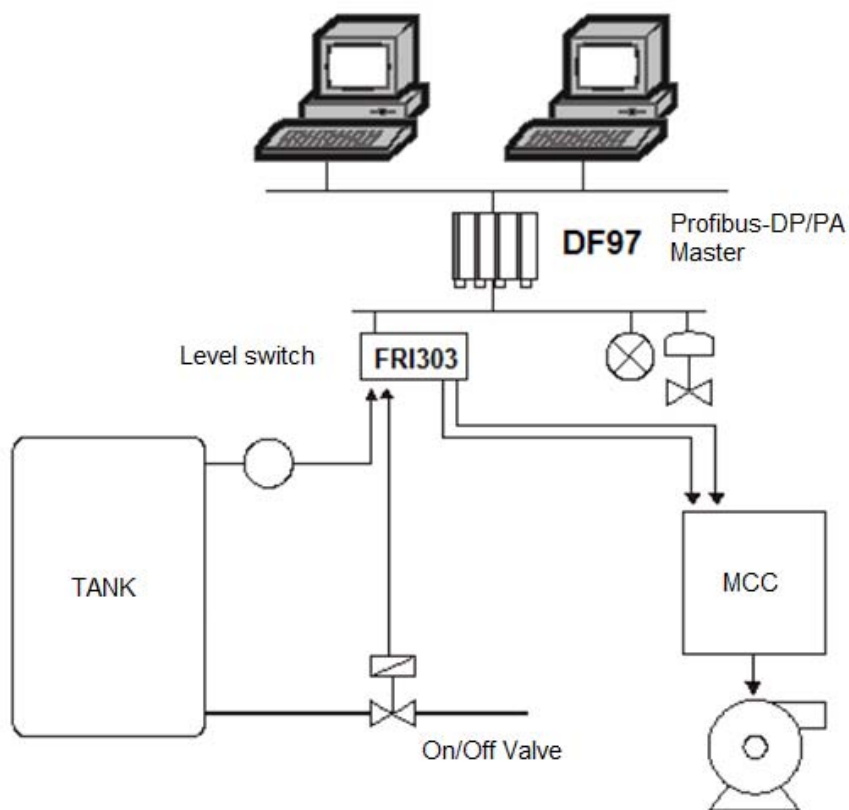

Figure 3.5 – FRI303 – Application 3

FRI303 Cyclical Configuration

PROFIBUS-DP as well as PROFIBUS-PA foresees protocol mechanisms against communication failures and errors and, as an example, during the initialization, several errors sources are verified. After the power up the field equipments (slaves) are ready for the cyclical data exchange with the Class1 master, but, for that, the master parameterization for the correspondent slave must be correct. This information is obtained through the GSD files, which should be one for each device.

Through the commands below, the master executes every initialization process with PROFIBUS-PA devices:

- **Get_Cfg:** carries the slaves' configuration and verifies the net configuration;
- **Set_Prm:** writes in the slaves' parameters and executes net parameterization services;
- **Set_Cfg:** configures the slaves according to inputs and outputs;
- **Get_Cfg:** a second command, where the master will verify the slaves' configuration.

All these services are based on the information obtained of GSD slaves' files. The GSD file of **FRI303** presents details of hardware revision and software, bus timing of the device and information on cyclical data exchange.

The **FRI303** has 2 DI and 2 DO blocks. Most of the PROFIBUS configurators use 2 directories. These directories must have the GSD's and bitmap's files of several manufacturers. The GSD and bitmap's files for Smar devices can be purchased via internet in www.smar.com.

See below a typical example with the necessary steps to the integration of a **FRI303** device in a PA system and that can be extended for any device:

- Copy the GSD file of the device for the search directory of the PROFIBUS configurator, usually named GSD.
- Copy the bitmap file of the device for the search directory of the PROFIBUS configurator, usually named BMP.
- Once the master is chosen, the communication rate must be chosen, remembering that when we had the couplers, we can have the following rates: 45.45 kbits/s (Siemens), 93.75 kbits/s (P+F) and 12 Mbits/s (P+F, SK2) .If we had the link device, it can be up to 12 Mbits/s. Add the **FRI303**, specifying the address in the bus.
- Choose the cyclical configuration via parameterization with the GSD file, dependent of the application. For each DO and DI block, the **FRI303** provides two bytes to the Profibus DP Master, one the discrete value and one status byte. Please see the cyclic options for **FRI303**:

```

;Empty module
Module = "EMPTY_MODULE"          0x00;
EndModule
;
;
;Modules for Discrete Output Block
Module = "SP_D"                   0xA1;

EndModule

Module = "SP_D+RB_D"              0xC1, 0x81, 0x81, 0x83;

EndModule
Module = "SP_D+CB_D"              0xC1, 0x81, 0x82, 0x92 ;

EndModule
Module = "SP_D+RB_D+CB_D"         0xC1, 0x81, 0x84, 0x93;

EndModule
Module = "RIN_D+ROUT_D"          0xC1, 0x81, 0x81, 0x8C;

EndModule
Module = "RIN_D+ROUT_D+CB_D"     0xC1, 0x81, 0x84, 0x9C;

EndModule
Module = "SP_D+RB_D+RIN_D+ROUT_D+CB_D" 0xC1, 0x83, 0x86, 0x9F;

EndModule

;Modules for Discrete Input Block

Module = "OUT_D"                  0x91;

```

EndModule

- The watchdog condition can also be activate, where after the communication loss detection for the slave device with the master, the equipment can change to a fail-safe condition.

The **FRI303** also has the Empty module for application where is not necessary all function blocks. There is an order for cyclic communication as follow:
DO_1, DO_2, DI_, DI_2.

For example, where is necessary to work only with DOs blocks, we have:
DO_1, DO_2, EMPTY_MODULE, EMPTY_MODULE

Suppose now the application will work with one DOs blocks and one DI2:
DO_1, EMPTY_MODULE, DI_2 , EMPTY_MODULE

```

;Empty module
Module = "EMPTY_MODULE"           0x00;
EndModule
;
;
;Modules for Discrete Output Block
Module = "SP_D"                   0xA1;

EndModule

Module = "SP_D+RB_D"              0xC1, 0x81, 0x81, 0x83;

EndModule
Module = "SP_D+CB_D"              0xC1, 0x81, 0x82, 0x92;

EndModule
Module = "SP_D+RB_D+CB_D"         0xC1, 0x81, 0x84, 0x93;

EndModule
Module = "RIN_D+ROUT_D"           0xC1, 0x81, 0x81, 0x8C;

EndModule
Module = "RIN_D+ROUT_D+CB_D"      0xC1, 0x81, 0x84, 0x9C;

EndModule
Module = "SP_D+RB_D+RIN_D+ROUT_D+CB_D" 0xC1, 0x83, 0x86, 0x9F;

EndModule

;Modules for Discrete Input Block

Module = "OUT_D"                   0x91;

EndModule

```

- The watchdog condition can also be activate, where after the communication loss detection for the slave device with the master, the equipment can change to a fail safe condition.

If the DO blocks are in AUTO, then the device will receive the value and status of the discrete setpoint of the class 1 master and the user will also be able to write in this value via class 2 master. In this case, the setpoint status should always be equal to 0x80 ("good") and the following configurations can be chosen:

- SP_D
- SP_D+RB_D
- SP_D+RB_D+CB_D

If the DO blocks are in RCAS, then the device will receive the value and status of the discrete setpoint only via class 1 master. In this case, the setpoint status should always be equal to 0xc4 ("IA"). The following configurations can be chosen:

- SP_D
- SP_D+RB_D
- SP_D+RB_D+CB_D
- RIN_D+ROUT_D
- RIN_D+ROUT_D+CB_D
- SP_D+RB_D+RIN_D+ROUT_D+CB_D

Cyclical Diagnosis

Via cyclic communication is possible to verify diagnostics from the **FRI303** using the Profibus Master Class 1 or even via acyclic communication via Master Class 2. The Profibus-PA devices provide up to 4 bytes standard diagnoses via Physical Block (See figure 3.6. and 3.7) and when the most significant bit of the fourth Byte is "1", the diagnose will extend the the information in more 6 bytes. These Diagnosis bytes can also be monitored via cyclic tools.

Len of status bytes	Status Type	Physical Block Slot	Status		Standard Diagnostic	Extended Diagnostic
			Appears	Dissappears		
08 - Standard Diag 0E - Ext Diag	FE	01	01 - Appears	02- Dissappears	4 bytes	6 bytes veedor specific

From Physical Block

When bit 55 (byte 4, MSB) is "1":
the device has extended diagnostic.

Figure 3.6 – Cyclical Diagnosis

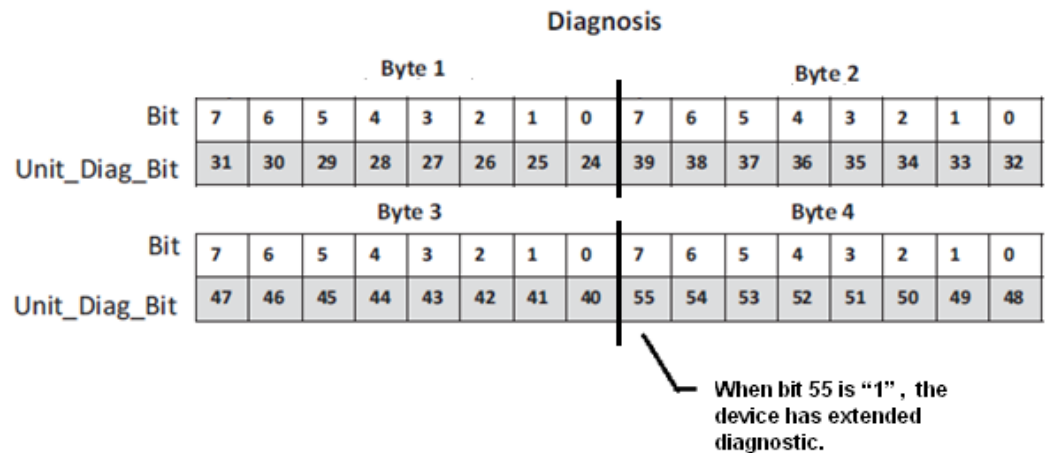

Figure 3.7 – Cyclic Diagnosis mapping for 4 bytes of Physical Block.

Unit_Diag_bit is described in the GSD file Profibus-PA device.

See below a description part of a GSD file for the 4 bytes and more detail:

```

;----- Description of device related diagnosis: -----
;
Unit_Diag_Bit(16) = "Error appears"
Unit_Diag_Bit(17) = "Error disappears"
;
;Byte 01
Unit_Diag_Bit(24) = "Hardware failure electronics"
Unit_Diag_Bit(25) = "Not used 25"
Unit_Diag_Bit(26) = "Not used 26"
Unit_Diag_Bit(27) = "Not used 27"
Unit_Diag_Bit(28) = "Memory error"
Unit_Diag_Bit(29) = "Not used 29"
Unit_Diag_Bit(30) = "Device not initialized"
Unit_Diag_Bit(31) = "Device initialization failed"

;Byte 02
Unit_Diag_Bit(32) = "Not used 32"
    
```



```

Unit_Diag_Bit(33) = "Not used 33"
Unit_Diag_Bit(34) = "Configuration invalid"
Unit_Diag_Bit(35) = "Restart"
Unit_Diag_Bit(36) = "Coldstart"
Unit_Diag_Bit(37) = "Maintenance required"
Unit_Diag_Bit(38) = "Not used 38"
Unit_Diag_Bit(39) = "Ident_Number violation"

;Byte 03
Unit_Diag_Bit(40) = "Not used 40"
Unit_Diag_Bit(41) = "Not used 41"
Unit_Diag_Bit(42) = "Not used 42"
Unit_Diag_Bit(43) = "Not used 43"
Unit_Diag_Bit(44) = "Not used 44"
Unit_Diag_Bit(45) = "Not used 45"
Unit_Diag_Bit(46) = "Not used 46"
Unit_Diag_Bit(47) = "Not used 47"

;byte 04
Unit_Diag_Bit(48) = "Not used 48"
Unit_Diag_Bit(49) = "Not used 49"
Unit_Diag_Bit(50) = "Not used 50"
Unit_Diag_Bit(51) = "Not used 51"
Unit_Diag_Bit(52) = "Not used 52"
Unit_Diag_Bit(53) = "Not used 53"
Unit_Diag_Bit(54) = "Not used 54"
Unit_Diag_Bit(55) = "Extension Available"

; Extended Diag
Unit_Diag_Bit(56) = "Transducer Block in Out of Service"
Unit_Diag_Bit(57) = "Not used 57"
Unit_Diag_Bit(58) = "Not used 58"
Unit_Diag_Bit(59) = "Not used 59"
Unit_Diag_Bit(60) = "Not used 60"
Unit_Diag_Bit(61) = "Not used 61"
Unit_Diag_Bit(62) = "Not used 62"
Unit_Diag_Bit(63) = "Device is writing lock"

;
Unit_Diag_Bit(64) = "Simulation Active in DI 1 Block"
Unit_Diag_Bit(65) = "Simulation Active in DI 2 Block"
Unit_Diag_Bit(66) = "Not used 66"
Unit_Diag_Bit(67) = "Not used 67"
Unit_Diag_Bit(68) = "Not used 68"
Unit_Diag_Bit(69) = "Not used 69"
Unit_Diag_Bit(70) = "Not used 70"
Unit_Diag_Bit(71) = "Not used 71"

;
Unit_Diag_Bit(72) = "Fail Safe Active in DI 1 Block"
Unit_Diag_Bit(73) = "Fail Safe Active in DI 2 Block"
Unit_Diag_Bit(74) = "Not used 74"
Unit_Diag_Bit(75) = "Not used 75"
Unit_Diag_Bit(76) = "Not used 76"
Unit_Diag_Bit(77) = "Not used 77"
Unit_Diag_Bit(78) = "Not used 78"
Unit_Diag_Bit(79) = "Not used 70"

;
Unit_Diag_Bit(80) = "Fail Safe Active in DO 1 Block"
Unit_Diag_Bit(81) = "Fail Safe Active in DO 2 Block"
Unit_Diag_Bit(82) = "Not used 82"
Unit_Diag_Bit(83) = "Not used 83"
Unit_Diag_Bit(84) = "Simulation Active in DO 1 Block"
Unit_Diag_Bit(85) = "Simulation Active in DO 2 Block"
Unit_Diag_Bit(86) = "Not used 86"

```

```
Unit_Diag_Bit(87) = "Not used 87"

;
Unit_Diag_Bit(88) = "DI 1 Block: Out of Service"
Unit_Diag_Bit(89) = "DI 2 Block: Out of Service"
Unit_Diag_Bit(90) = "Not used 90"
Unit_Diag_Bit(91) = "Not used 91"
Unit_Diag_Bit(92) = "Not used 92"
Unit_Diag_Bit(93) = "Not used 93"
Unit_Diag_Bit(94) = "Not used 94"
Unit_Diag_Bit(95) = "Not used 95"

;
Unit_Diag_Bit(96) = "DO 1 Block: Out of Service"
Unit_Diag_Bit(97) = "DO 2 Block: Out of Service"
Unit_Diag_Bit(98) = "Not used 98"
Unit_Diag_Bit(99) = "Not used 99"
Unit_Diag_Bit(100) = "Not used 100"
Unit_Diag_Bit(101) = "Not used 101"
Unit_Diag_Bit(102) = "Not used 102"
Unit_Diag_Bit(103) = "Not used 103"
```

NOTE

If the FIX flag is active on LCD, the **FRI303** is configured to "Profile Specific". When in "Manufacturer Specific", the Identifier Number is 0x0dcb. Once the Identifier_Number_Selector is changed from "Profile Specific" to "Manufacturer Specific" or vice-versa, you must wait 5 seconds while it is saved and then turn off the **FRI303** and then the identifier is updated in the level of communication. If the equipment is in "Profile Specific" and using the GSD file Identifier Number equals 0x0dcb, the acyclic communication will work well with tools based on EDDL, FDT/DTM, but no cyclic communication with the Profibus-DP master will get success.

Section 4

MAINTENANCE PROCEDURES

General

SMAR **FRI303** is extensively tested and inspected before delivery to the end user. Nevertheless, during their design and development, consideration has been given to the possibility of repairs by the end user, when necessary.

In general, it is recommended for the end user not to try to repair printed circuit boards. Instead, spare circuit boards should be available, which may be ordered from SMAR when necessary.

TROUBLESHOOTING	
SYMPTOM	PROBABLE SOURCES OF TROUBLE
NO QUIESCENT CURRENT	<p>Connections: Check wiring polarity and continuity.</p> <p>Power Supply: Check power supply output. The voltage at the FRI303 Profibus-PA terminals must be between 9 and 32 Vdc.</p> <p>Electronic Circuit Failure: Check the boards for defects by replacing them with spare ones.</p>
NO COMMUNICATION	<p>Network Connections Check the network connections: devices, power supply, and terminators.</p> <p>Network Impedance Check the network impedance (power supply impedance and terminators).</p> <p>Controller Configuration Check configuration of communication parameters of the controller</p> <p>Physical address Check the device address and make sure the configuration at the Profibus Master has the same address.</p> <p>Network Configuration Check communication configuration of the network.</p> <p>Electronic Circuit Failure Check the boards for defects by replacing them with spare ones.</p>
INCORRECT OUTPUTS	<p>Output Terminals Connection Check wiring and continuity.</p> <p>Switching Current and voltage for Outputs Check limits for the connected load according to the model for relay connections.</p> <p>Output Fuse Check the condition Of the output Fuses by removing the main electronic board.</p>

Disassembly Procedure

See Figure 4.1 – **FRI303** Exploded View. Make sure to disconnect the power supply before disassembling the converter.

To remove the circuit boards (**5** and **6**) and display (**4**), first loosen the cover locking (**7**) on the side not marked “Field Terminals”, then unscrew the cover (**1**).

WARNING
The boards have CMOS components, which may be damaged by electrostatic discharges. Observe correct procedures for handling CMOS components. It is also recommended to store the circuit boards in electrostatic-proof cases.

Loosen the two screws (**3**) that anchor the display and the main circuit board. Gently pull out the display (**4**), and then the main board (**5**). To remove the input board (**6**), first unscrew the two screws that anchor it to the housing (**15**), and gently pull out the board.

Reassembly Procedure

- Place the input board (6) into housing (15);
- Place the main board (5) into the housing (15), ensuring all inter connecting pins are connected;
- Place the display (4) into the housing, note the four mounting positions. "_" should point in the direction desired as UP;
- Anchor main board (5) and display with their screws (3);
- Fit the cover (1 and 13) and lock it using the locking screws (7 and 18).

Firmware Update Procedure

For firmware update of the FRI303 equipment see FDI302-1 manual, visit website Smar: www.smar.com

Accessories

Main and I/O boards can be changed independently.

ACCESSORIES	
ORDERING CODE	DESCRIPTION
PBI-PLUS	USB Interface for Profibus PA.
SYSCON	System Configuration Tool.
PS302	Power Supply.
BT302	Terminator.
FDI302-1	Fieldbus/PROFIBUS-PA Communication Interface for Firmware Update.
DF47	Intrinsic Safety Barrier for Fieldbus.

Exploded View

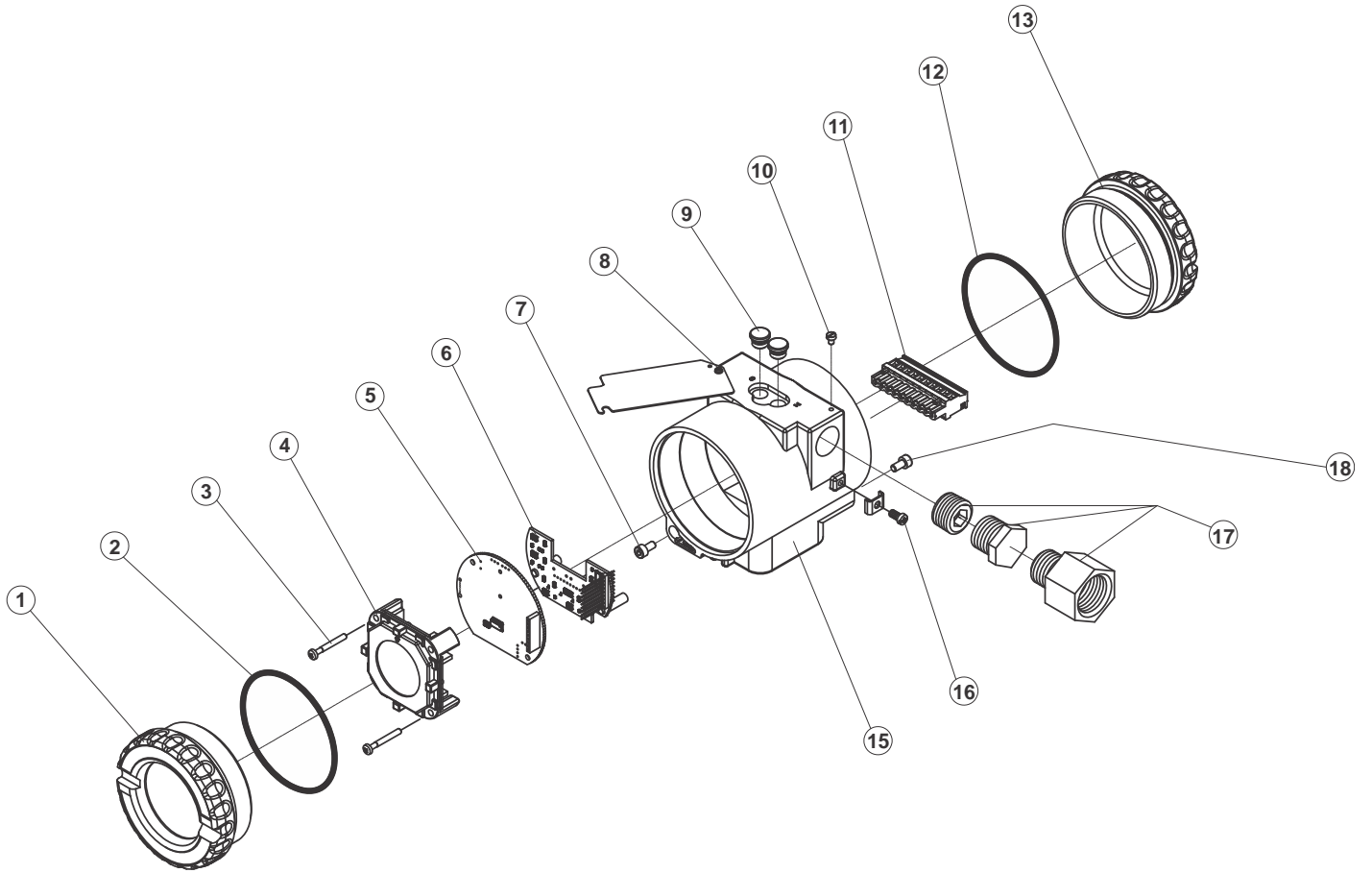

Figure 4.1 – FRI303 Exploded View

Spare Parts

SPARE PARTS		
DESCRIPTION	POSITION	CODE
Housing		
Main Electronic Board		
Interface Board		
I/O Board		

Section 5

TECHNICAL SPECIFICATIONS

General

Communication	Digital only. PROFIBUS-PA, 31.25 Kbits/s voltage mode, according to IEC 61158-2.
Current consumption quiescent	17.5 mA from Profibus-PA network.
Turn-on Time	Approximately 10 seconds.
Update Time	Approximately 0.5 second.
Humidity Limits	0 to 100% RH.
Output Impedance	Non-intrinsic safety from 7.8 kHz - 39 kHz should be greater or equal to 3 k Ω . Intrinsic safety output impedance (assuming an IS barrier in the power supply) from 7.8 kHz – 39 kHz should be greater or equal to 400 Ω .
Function Blocks	2 Discrete Input Function Blocks (DIs) and 2 Discrete Output Function Blocks (DOs).
Indication	Optional 4½ digit LCD indicator.
Temperature Limits	Operation: -40 to 85°C (-40 to 185 °F). Storage: -40 to 120°C (-40 to 250 °F). Display: -10 to 60°C (14 to 140°F) operation; -40 to 85°C (-40 to 185 °F) without damage.
Vibration Effect	Meets SAMA PMC 31.1.
Electro-Magnetic Interference Effect	Designed to comply with IEC 801.
Hardware	Physical: according to IEC 61158-2 and conformity with the FISCO model.
Electrical Connection	1/2-14 NPT, PG 13.5 or M20 x 1.5.
Material of Construction	Injected low copper aluminum with polyester painting or 316 Stainless Steel housing, with Buna N O-rings on cover (NEMA 4X, IP67).
Mounting	With an optional bracket that can be installed on a 2" pipe or fixed on a wall or panel.
Weight	Without display and mounting bracket: 0.80 kg. Add for digital display: 0.13 kg. Add for mounting bracket: 0.60 kg.

FRI303 Output Relays

Description - Outputs

The outputs are designed with Solid State relays that are able to drive incandescence lamps, solenoids and other DC and AC loads.

When the output relays are N.C., if via function block is assigned a state on to the outputs, it means that the loads will be switched off.

When the output relays are N.O., if via function block is assigned a state on to the outputs, it means that the loads will be switched on.

Technical specifications for Normally Closed relays

Architecture	Number of Outputs: 2.
Switching Voltage	350 V _{peak} .
Switching Current: AC mode	100 mA.
Switching Current: DC mode	165 mA.

On Resistance AC mode	18 Ω.
On Resistance DC mode	4.5 Ω.
Off State Resistance	Min: 0.1 GΩ. Typ: 1.4 GΩ.
Off State Leakage	Typ: 1.0 μA.
Turn On Time	5 ms.
Turn Off Time	1 ms.
Capacitance - Across Output	20 to 200 pF.
Thermal Offset Voltage	0.20 mV.
Output Status (load) with no power supply connected to the Profibus-PA bus	ON
Output Status (load) During: Firmware Download	ON
Output Status (load) During: Turn-on Time	ON

Technical specifications for Normally Opened relays

Architecture	Number of Outputs: 2.
Switching Voltage	400 V _{peak} .
Switching Current: AC mode	150 mA.
Switching Current: DC mode	250 mA.
On Resistance AC mode	18 Ω.
On Resistance DC mode	4.5 Ω.
Off State Resistance	Min: 0.5 GΩ. Typ: 5000 GΩ.
Off State Leakage	Typ: 0.5 μA.
Turn On Time	5 ms.
Turn Off Time	1 ms.
Capacitance - Across Output	10 to 95 pF.
Thermal Offset Voltage	0.20mV.
Output Status (load) with no power supply connected to the Profibus-PA bus	OFF
Output Status (load) During: Firmware Download	OFF
Output Status (load) During: Turn-on Time	OFF

Technical Specifications for Dry Contact Input

Digital Input	2 (two) dry contact inputs electrically isolated from each other: <ul style="list-style-type: none"> • Resistance value lower than 2 KΩ: close contact; • Resistance value upper than 3.5 KΩ: open contact.
----------------------	---

Ordering Code

MODEL	
FRI303	PROFIBUS-PA REMOTE I/O
COD.	Local Indicator
0	Without Indicator
1	With Digital Indicator
COD.	Relay Output Condition
1	Both Normally Open (N.O.)
2	Both Normally Closed (N.C.)
3	One N.O. and other N.C.
COD.	Mounting Bracket for 2" Pipe Mounting
0	Without Bracket
1	Carbon Steel Bracket
2	316 SST Bracket
COD.	Electrical Connections
0	1/2-14 NPT
A	M20 x 1.5
B	PG 13.5 DIN
COD.	Options
H0	Housing - Aluminum (IP/TYPE)
H1	Housing - 316 SST (IP/TYPE)
A1	316 SST Bolts
ZZ	Special Options – Specify

FRI303	-	1		1	-	1		0	/	*
--------	---	---	--	---	---	---	--	---	---	---

TYPICAL MODEL

* Leave it blank for no optional items

Appendix A

	SRF – SERVICE REQUEST FORM		
	Profibus-PA Remote Input and Output		
GENERAL DATA			
Model:	FRI303		
Serial Number:	_____		
TAG:	_____		
Channels being used in FRI303:	INPUT	1 ()	
		2 ()	
	OUTPUT	1 ()	
		2 ()	
Configuration:	PC ()	Software: _____	Version: _____
INSTALLATION DATA			
Type/Model/Manufacturer of device connected to FRI303:	_____		

PROCESS DATA			
Hazardous Area Classification:	() Yes, please specify: _____		
	() No		
	More details: _____		
Interference types present in the area:	No interference ()	Temperature ()	Vibration () Other: _____
Environment Temperature:	From _____ °C up to _____ °C.		
OCCURRENCE DESCRIPTION			

SERVICE SUGGESTION			
Adjustment ()	Cleaning ()	Preventive Maintenance ()	Update / Up-grade ()
Other: _____			
USER INFORMATION			
Company:	_____		
Contact:	_____		
Title:	_____		
Section:	_____		
Phone:	_____	Extension:	_____
E-mail:	_____	Date:	____/____/____
For warranty or non-warranty repair, please contact your representative. Further information about address and contacts can be found on www.smar.com/contactus.asp .			

Returning Materials

If necessary to return the FRI303 to SMAR, simply contact our office, informing the defective instrument serial number, and return it to our factory.

In order to speed up analysis and solution of the problem, the defective item should be returned with a description of the failure observed, with as much details as possible. Other information concerning the instrument operation, such as service and process conditions, is also helpful.

Instruments returned or to be revised outside the guarantee term should be accompanied by a purchase order or a quote request.